



50BF Series

Single-Package Cooling Units

90,000-895,500 BTUH



www.carrier.co.th

www.ttair.co.th | Tel : 02-385-0728 | E-mail : sales@ttair.co.th | LINE ID : @ttair

50BF Series



◀ With electronic thermostat controller IR33 all model

Features

- Commercial or Industrial Applications
- Single- or Multiple-Unit Systems
- Ductwork Applications
- Efficient
- Reliable
- Easy to Install

Technical specification

Description		Single-Package Cooling Unit																
Model		50BF008SC	50BF010SC	50BF015SC	50BF020SC	50BF020	50BF025SC	50BF025	50BF030SC	50BF030	50BF040SC	50BF040	50BF050SC-1	50BF050-1	50BF060SC-1	50BF060-1	50BF080-1	
Nominal Capacity	kW	26.4	34.1	55.6	69.5	69.5	81.7	81.7	100.9	100.9	132.1	132.1	160.2	160.2	198.2	198.2	262.5	
	Btu/Hr	90,000	116,300	189,600	237,100	237,100	278,700	278,700	344,300	344,300	450,600	450,600	546,600	546,600	676,100	676,100	895,500	
	Tons	8	10	16	20		23	23	29	29	38	38	46	46	56	56	75	
Power consumption	kW	6.90	9.90	13.37	18.25	20.00	20.00	20.15	27.60	27.00	36.46	36.70	42.46	37.50	54.69	51.50	69.70	
Operation current	A	13.50	17.70	29.00	34.80	38.00	37.23	38.00	57.00	55.20	64.00	76.00	77.86	76.00	97.60	96.00	152.00	
Operating Weight	kg	266	318	581	650	668	745	760	810	830	1,050	1,000	1,921	1,921	2,160	2,160	2,660	
Operating Charge		Refrigerant type : R-407C																
Circuit 1	kg	7.0	9.5	11.0	15.0	15.0	21.0	21.0	24.0	24.0	30.0	30.0	22.0	22.0	26.0	26.0	31.5	
	kg	-	-	-	-	-	-	-	-	-	-	-	22.0	22.0	26.0	26.0	31.5	
Condenser	Type	Shell and Tube																
	Water Flow Rate	GPM	16	20	36	48	48	60	60	72	72	92	92	144	120	184	144	184
	PD	FT.WG	21	26	20	20	20	20	20	25	25	25	20	20	25	25	25	25
	Number		1	1	1	1	1	1	1	1	1	1	2	2	2	2	2	2
Compressor	Type	Scroll					Reciprocating		Scroll		Reciprocating		Scroll		Reciprocating		Reciprocating	
	Model	ZR108KCE-TFD	ZR144KFE-TFD	ZR190KCE-TFD	ZR250KCE-TFD	06E2250611	ZRT288KCE-TFD	06E2250611	ZRT380KCE-TFD	06E2265611	ZRT500KCE-TFD	06E6299681	ZR310KCE-TWD	06E2250611	ZR380KCE-TWD	06E2265611	06E6299681	
	Qty	1	1	1	2	1	2	1	2	1	2	1	2	2	2	2	2	
Circuit 1, Circuit 2	No. of Unloading Cylinders	-	-	-	-	1	-	1	-	1	-	1	-	-	-	-	-	
	No. of Capacity Step	-	-	-	2	2	2	2	2	2	2	2	2	2	2	2	2	
Indoor Fan	Type	Belt Driven Centrifugal																
	No.	1	1	1	1	1	1	1	1	1	2	2	2	2	2	2	2	
	Diameter	inch	12 x 12	12 x 12	15 x 15	15 x 15	15 x 15	18 x 18	18 x 18	18 x 18	15 x 15	15 x 15	18 x 18	18 x 18	20 x 20	20 x 20	20 x 20	
	Std. Fan revolution speed	rpm	789	800	794	960	960	643	643	720	720	820	820	538	538	659	659	730
	Max. Fan revolution speed	rpm	1,500	1,500	1,200	1,200	1,200	1,100	1,100	1,100	1,100	1,200	1,200	1,200	1,200	1,200	1,200	
	No. of Belts... Fan Pulley Pt	inch	1..9	1..9	1..9	1..9	1..9	2..11	2..11	2..10	2..10	2..12	2..12	2..16	2..16	2..16	2..16	
	Motor Pulley PDR	inch	5	5	5	6	6	5	5	5	5	7	7	7	7	7	8	
	Motor Std.	Kwhp	0.75 (1HP)	1.5 (2HP)	2.2 (3HP)	3.7 (5HP)	3.7 (5HP)	3.7 (5HP)	3.7 (5HP)	5.5 (7.5HP)	5.5 (7.5HP)	7.5 (10HP)	7.5 (10HP)	7.5 (10HP)	7.5 (10HP)	11 (15HP)	11 (15HP)	15 (20HP)
	Alternate	kW	1.5 (2HP)	-	3.7 (5HP)	5.5 (7.5HP)	5.5 (7.5HP)	5.5 (7.5HP)	5.5 (7.5HP)	7.5 (10HP)	7.5 (10HP)	5.5 (7.5HP)	5.5 (7.5HP)	-	-	-	-	
	BELT		B-39	B-38	B-42	B-42	B-42	B-58	B-58	B-55	B-55	B-65	B-65	B-122	B-122	B-122	B-122	
Indoor Coil	Tube/Fin type	3/8 Copper tube / Aluminium fin																
	Row...Fin per Inch	3...15	3...15	3...13	3...13	3...13	4...15	4...15	4...15	4...15	4...15	4...15	3...15	3...15	4...15	4...15	4...14	
	Total Face Area	sq.ft.	5.81	7.85	11.72	15.60	15.60	15.60	15.60	18.83	18.83	24.53	24.53	40.22	40.22	40.22	40.22	
Return Air Filters		Factory Supplied																
	No.	1	1	1	1	1	6	6	6	6	8	8	15	15	15	15	18	
	Size(WxHxD)	inch	34.5x23.0	46.0x23.0	46x35	62x35	62x35	20x23x1	20x23x1	20x23x1	20x23x1	20x23x1	20x23x1	20x23x1	20x23x1	20x23x1	20x23x1	
Safety Device	Hi-Pressure Switch	360 / 270 (Cut out / Cut in) - Auto Restart type																
	Low-Pressure Switch	30 / 60 (Cut out / Cut in) - Auto Restart type																

PDR : Pitch Diameter Range
 PD : Pulley Pitch Diameter
 All water connection sizes are in MPT.

Note : NOMINAL TOTAL CAPACITY BASED ON NOMINAL EVAPORATOR AIR, 67° F ENTERING WET BULB AND 95° F CONDENSER LEAVING WATER TEMPERATURE.

Remark : Option

1. Hi-Pressure Switch-Manual Reset Type
2. Low-Pressure Switch-Manual Reset Type

Unit 50BF		008 to 015	020 to 030	040	050 to 060	080
Size	Condenser Inlet No.inch	1.....2	1.....2 1/2	1.....3	2.....2 1/2	2.....3
	Condenser Outlet No.inch	1.....2	1.....2 1/2	1.....3	2.....2 1/2	2.....3

Unit dimensions

Model : 50BF008, 010

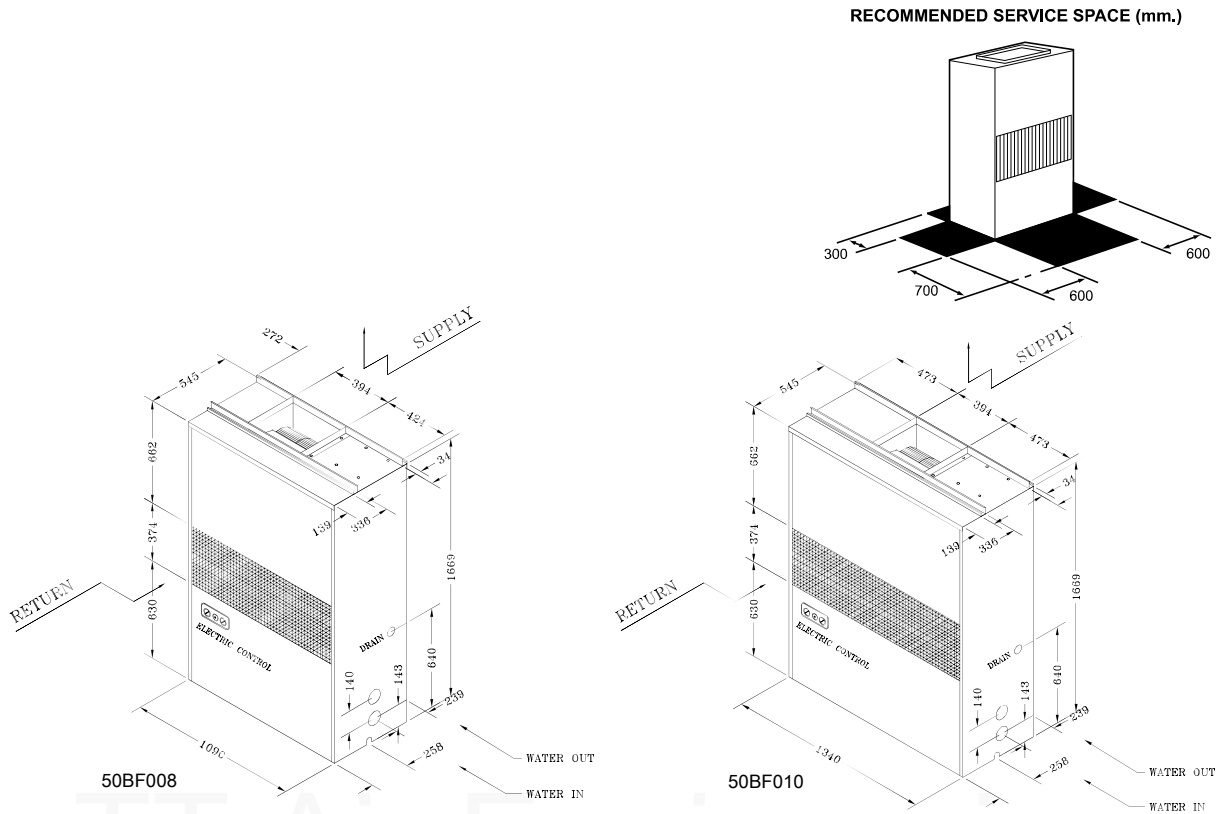

Model : 50BF015, 020

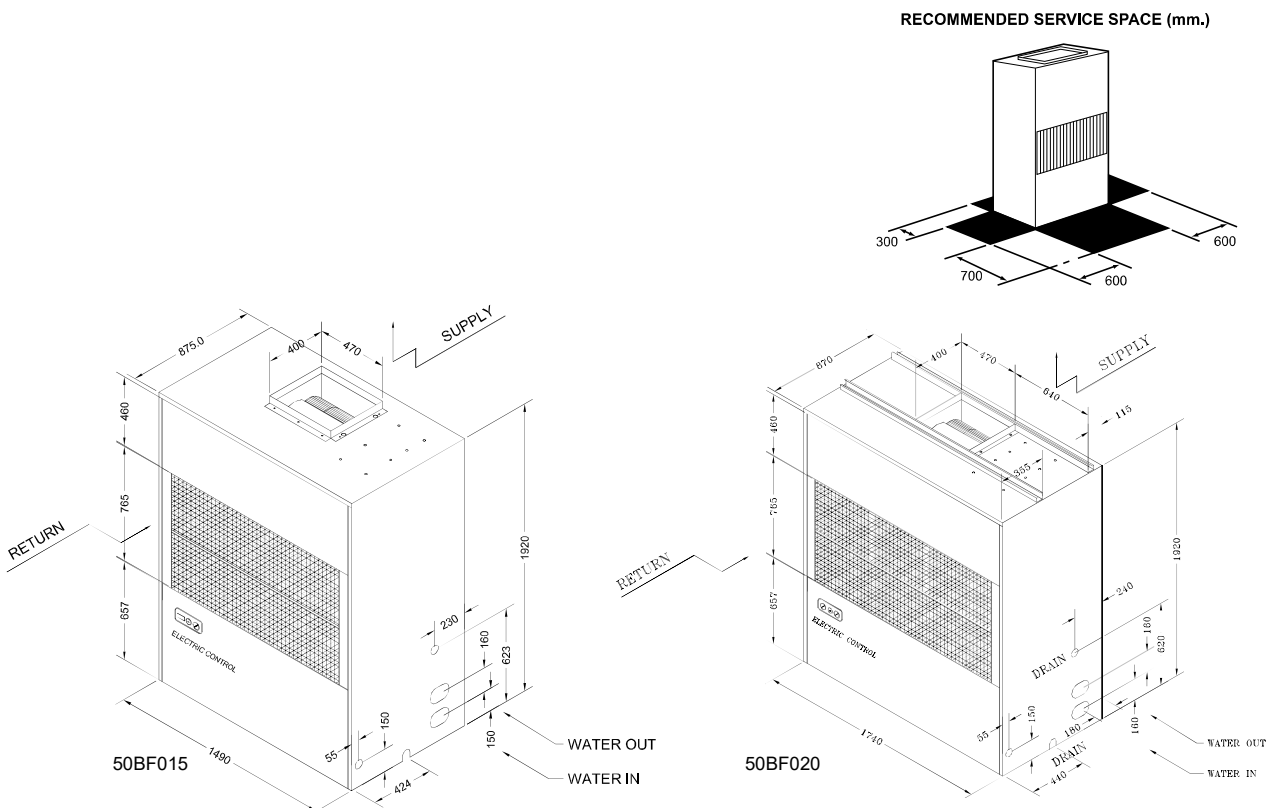

Unit dimensions

Model : 50BF 025, 030

Unit	A	B	C
50BY025, 030	800	1800	1890

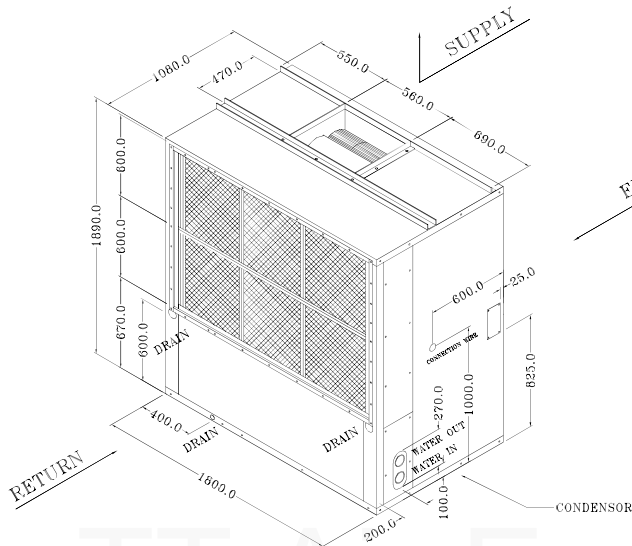

RECOMMENDED SERVICE SPACE (mm.)

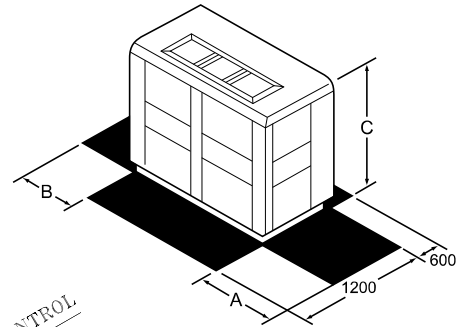

Model : 50BF 040

Unit	A	B	C
50BY040	800	2300	1890

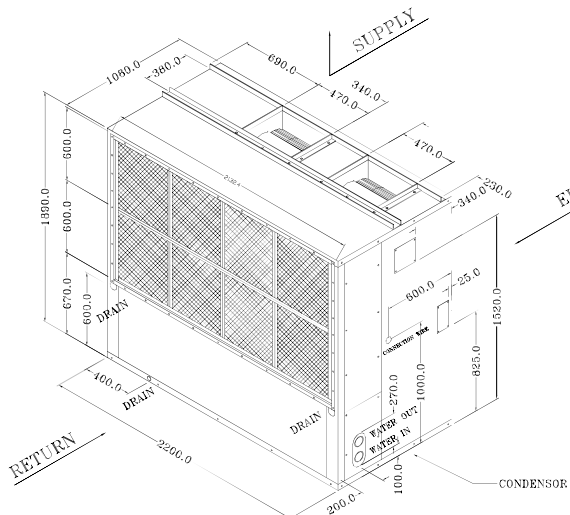

RECOMMENDED SERVICE SPACE (mm.)

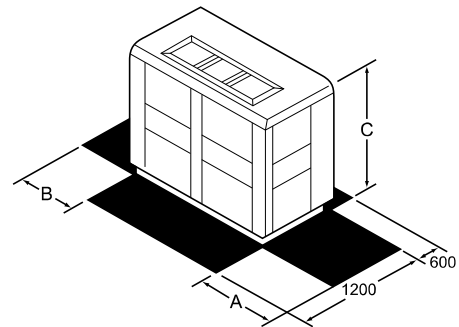

Unit dimensions

Model : 50BF050-1, 060-1, 080-1

Unit	A	B	C
50BF050-1	2600	800	1900
50BF060-1	2600	800	1900
50BF080-1	3100	800	1900

RECOMMENDED SERVICE SPACE (mm.)

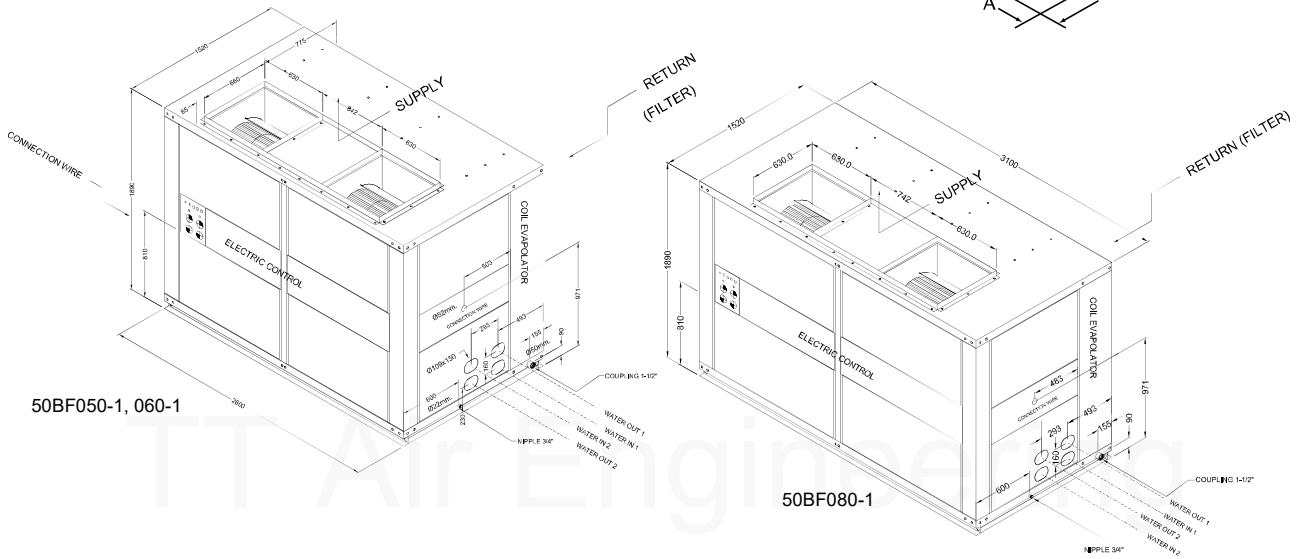
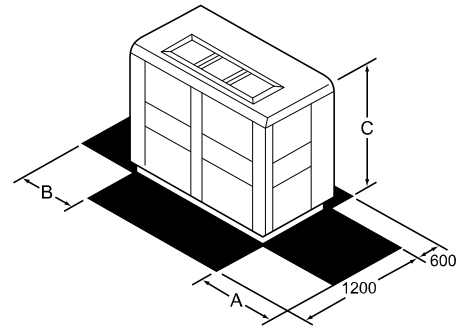

Engineering excellence assures outstanding performance

- Compressor** - 50BF008SC, 50BF010SC and 50BF015SC, 50BF050SC-1, 50BF060SC-1, 50BF020SC, 50BF025SC, 50BF030SC, 50BF040SC, 50BF050SC-1, 50BF060SC-1 Fully hermetic Compressors. For unit 50BF020, 50BF025, 50BF030, 50BF040, 50BF050-1, 50BF060-1, 50BF080-1 use the 06E serviceable hermetics. Carrier compressors deliver quiet, reliable high-cooling capacity at low cost.
- Compressor motor protection** - assured on all units by use of quick-sensing elements that prevent trouble before it starts.
- Quiet, high-capacity fans** - move large volumes of indoor air quietly and at a lower rpm than most comparable fans. Compact housing and specially designed discharge give fans superior air handling capability.
- Evaporator coils** - Space saving slab type provides high heat transfer efficiency with large face area; fins are mechanically bonded to seamless copper tubing for high-capacity performance.
- High-efficiency condensers** - shell and tube construction provide maximum exposed surface for more heat rejection with less water.
- Crankcase heaters** - (06E Compressor) remain on during compressor off cycle to prevent dilution of oil by refrigerant...thus, preventing flooded parts.

Selection procedure (with example)

1. Determine job requirements.

Given:

Cooling load (TC:Btu/h).....	270,000
(SHC:Btu/h).....	197,000
Evap. air quantity (cfm).....	8,000
Evap. entering air conditions wb.....	67°F
db.....	80°F
Condenser entering water temp.....	90°F
Condenser leaving water temp.....	100°F
External static pressure (in WG).....	2.8

2. Select unit(s) based on cooling requirements.

- A. Enter Cooling Capacities tables at given evaporator air quantity (8,000 cfm.) and condenser leaving water temperature (100°F). By interpolation, if required, determine total cooling capacity (TC) and sensible heat capacity (SHC) at given evaporator entering air wb (67°F).

A 50BF025 unit has a capacity of 271,800 Btu/h (TC) and 197,600 Btu/h (SHC).

- B. Correct the SHC value for evaporator entering air db temperature other than 80°F.

For this example, no correction is required. The unit can satisfy specified cooling load requirement.

3. Determine required fan motor kW and fan rpm.

- A. Determine total static pressure by adding unit internal pressure drop to a specified external S.P. From 50BF025 fan curve, pressure drop for unit is found to be 0.4 in. WG. at the specified air quantity (8,000 CFM).
Total S.P. = 0.4+2.8 = 3.20 in. WG.

Locate on the curve where the specified air quantity and total S.P. (3.20) intersect.

The intersect point is under 3.7 kW line and fan rpm can be determined as 920 rpm. The standard 3.7 kW motor can satisfy the requirements.

4. Determine condenser water requirements.

- A. Required water flow can be determined using formula below:

$$\text{GPM} = \frac{\text{TC(Btu/h)} + \text{Compressor Power Input(KW)} \times 3414}{500 \times \text{Water Temp. Rise } (\Delta^{\circ}\text{F})}$$

$$= \frac{271800 + 17.9 \times 3414}{500 \times (100 - 90)} = 66.58$$

- B. Enter Condenser Pressure Drop table at the determined water flow (66.58 gpm.). Interpolate, if required, to obtain the water pressure drop (4.98 PSI).

A proper water pump can be selected based on this value.

Fan performance

- The fan performance curves are based on dry coil and clean Filters.
- Total static pressures are shown on the vertical scale of the chart. To determine external static pressure, deduct Unit Pressure Drop (casing loss bottom curves) from the total S.P. value read at a given air quantity.
- The kW values denote fan motor nominal output. The nominal 1.5 kW motor, for example, can cover the areas of Air Qty. Total S.P. and rpm shown under the line indicated as 1.5 kW.
- Use curves within the ranges shown. Do not exceed the ranges.

Motor selection

The power curve shown on every diagram represents the absorbed power at the shaft after fan measured in kW. To determine the power of the motor to be installed, the following correct factors have to be taken in consideration.

- For power less than 10 kW x 1.2
- For power more than 10 kW x 1.15

Performance data

50BF008

Gross Cooling Capacity Tables

Cond. Leaving Water Temp. (°F)		EVAP. Air Flow (CFM)								
		1,800			2,800			3,100		
		EVAP. Entering Air Temperature DB/WB (°F)								
		84/71	80/67	76/63	84/71	80/67	76/63	84/71	80/67	76/63
95	TC	95,100	87,200	79,600	97,900	90,000	82,400	99,800	91,700	84,100
	SHC	59,500	61,200	62,600	66,100	66,000	65,500	70,200	69,900	66,500
	KW	7.2	7.0	6.9	7.3	7.1	6.9	7.3	7.1	7.0
100	TC	93,000	85,100	78,100	95,600	87,800	80,500	97,400	89,400	82,100
	SHC	58,600	60,400	61,800	65,300	65,000	64,600	69,100	69,000	65,500
	KW	7.4	7.2	7.1	7.5	7.4	7.1	7.6	7.4	7.2
105	TC	90,900	83,100	76,500	93,400	85,500	78,600	95,000	87,200	80,000
	SHC	57,700	59,600	61,000	64,500	64,100	63,700	68,100	68,000	64,600
	KW	7.7	7.4	7.3	7.8	7.6	7.4	7.8	7.6	7.4

50BF010

Gross Cooling Capacity Tables

Cond. Leaving Water Temp. (°F)		EVAP. Air Flow (CFM)								
		2,600			3,800			4,200		
		EVAP. Entering Air Temperature DB/WB (°F)								
		84/71	80/67	76/63	84/71	80/67	76/63	84/71	80/67	76/63
95	TC	122,500	112,500	103,400	126,600	116,300	106,600	129,400	118,900	109,500
	SHC	80,100	81,700	82,800	88,100	87,900	86,800	93,900	93,600	86,400
	KW	10.9	10.6	10.3	10.9	10.7	10.5	11.0	10.8	10.6
100	TC	119,900	110,000	101,100	123,800	113,700	104,200	126,500	116,100	106,600
	SHC	78,800	80,400	81,500	87,000	86,600	85,500	92,600	92,300	85,200
	KW	11.3	11.0	10.7	11.4	11.1	10.9	11.5	11.2	10.9
105	TC	117,200	107,600	98,800	121,000	111,100	101,700	123,500	113,200	103,800
	SHC	77,400	79,100	80,100	85,800	85,300	84,200	91,300	90,900	84,100
	KW	11.7	11.4	11.0	11.8	11.5	11.2	11.9	11.6	11.3

50BF015

Gross Cooling Capacity Tables

Cond. Leaving Water Temp. (°F)		EVAP. Air Flow (CFM)								
		3,200			4,800			5,900		
		EVAP. Entering Air Temperature DB/WB (°F)								
		84/71	80/67	76/63	84/71	80/67	76/63	84/71	80/67	76/63
95	TC	199,900	183,500	168,100	206,300	189,600	173,900	211,100	193,900	177,800
	SHC	125,700	131,900	137,500	138,800	143,100	146,300	149,700	152,500	144,000
	KW	10.7	10.4	10.1	10.8	10.5	10.2	10.8	10.6	10.3
100	TC	195,600	179,400	164,100	201,800	185,100	169,800	206,200	189,200	173,600
	SHC	123,800	130,000	135,300	136,900	140,800	144,200	147,600	150,400	141,900
	KW	11.0	10.8	10.5	10.7	10.8	10.6	11.1	10.9	10.7
105	TC	191,200	175,200	160,100	197,200	180,600	165,800	201,400	184,500	169,400
	SHC	121,900	128,100	133,000	134,900	138,500	142,100	145,500	148,300	139,800
	KW	11.4	11.2	10.8	10.6	11.2	10.9	11.5	11.3	11.0

TC : TOTAL CAPACITY (BTUH)
 SHC : SENSIBLE HEAT CAPACITY (BTUH)
 DB : DRY-BULB TEMPERATURE

KW : COMPRESSOR MOTOR POWER INPUT (KILOWATTS)
 WB : WET-BULB TEMPERATURE
 CFM : CU. FT. PER MINUTE

Performance data

50BF020

Gross Cooling Capacity Tables

Cond. Leaving Water Temp. (°F)		EVAP. Air Flow (CFM)								
		4,300			6,400			7,600		
		EVAP. Entering Air Temperature DB/WB (°F)								
		84/71	80/67	76/63	84/71	80/67	76/63	84/71	80/67	76/63
95	TC	249,600	229,000	209,600	258,600	237,100	217,400	264,400	242,600	221,400
	SHC	163,300	170,000	176,700	180,100	184,000	186,900	192,900	196,400	186,200
	KW	17.5	18.4	16.6	17.4	17.0	16.5	17.5	17.1	16.6
100	TC	243,900	223,700	204,800	252,500	231,600	212,200	258,000	236,700	216,500
	SHC	160,600	167,300	173,600	177,400	181,000	171,600	190,300	193,500	175,500
	KW	18.0	18.1	17.1	18.0	18.1	17.1	18.1	17.6	17.2
105	TC	238,300	218,400	200,000	246,300	226,100	207,100	251,600	230,900	211,700
	SHC	157,900	164,600	170,600	174,800	178,100	156,400	187,600	190,700	164,800
	KW	18.5	17.8	17.5	18.8	18.2	17.8	18.9	18.4	17.9

50BF025

Gross Cooling Capacity Tables

Cond. Leaving Water Temp. (°F)		EVAP. Air Flow (CFM)								
		5,700			8,000			10,500		
		EVAP. Entering Air Temperature DB/WB (°F)								
		84/71	80/67	76/63	84/71	80/67	76/63	84/71	80/67	76/63
95	TC	287,200	264,500	244,100	302,600	278,700	256,900	312,500	288,000	266,200
	SHC	184,100	193,600	197,000	199,100	202,500	193,900	212,500	209,100	198,100
	KW	17.4	17.0	16.5	17.5	17.2	16.8	17.7	17.4	17.0
100	TC	280,300	258,600	238,000	294,800	271,800	248,200	304,500	281,000	259,300
	SHC	180,100	189,200	192,200	194,800	197,600	191,300	207,700	202,900	192,000
	KW	18.0	17.6	17.2	18.3	17.9	17.5	18.4	18.0	17.6
105	TC	273,400	252,700	231,900	287,000	265,000	239,500	296,500	274,000	252,400
	SHC	176,000	184,800	187,400	190,500	192,700	188,800	203,000	196,700	185,900
	KW	18.7	18.2	17.9	19.0	18.5	18.1	19.1	18.7	18.3

50BF030

Gross Cooling Capacity Tables

Cond. Leaving Water Temp. (°F)		EVAP. Air Flow (CFM)								
		6,800			9,500			12,700		
		EVAP. Entering Air Temperature DB/WB (°F)								
		84/71	80/67	76/63	84/71	80/67	76/63	84/71	80/67	76/63
95	TC	355,500	327,300	301,800	373,400	344,300	317,700	388,100	358,500	330,600
	SHC	226,300	239,800	245,300	245,300	251,200	249,000	263,000	259,900	247,900
	KW	24.1	23.3	22.5	24.6	23.8	23.0	25.0	24.2	23.4
100	TC	347,200	319,700	294,900	364,600	336,200	310,000	378,200	349,200	322,100
	SHC	221,500	234,100	238,900	239,900	245,100	242,300	257,200	253,000	240,500
	KW	25.2	24.3	23.5	25.7	24.9	24.0	26.1	25.3	24.4
105	TC	339,000	312,200	288,000	355,800	328,100	302,400	368,300	339,900	313,700
	SHC	216,600	228,400	232,500	234,500	239,000	235,500	251,400	246,200	233,200
	KW	26.3	25.4	24.6	26.8	26.0	25.1	27.2	26.4	25.5

TC : TOTAL CAPACITY (BTUH)
 SHC : SENSIBLE HEAT CAPACITY (BTUH)
 DB : DRY-BULB TEMPERATURE

KW : COMPRESSOR MOTOR POWER INPUT (KILOWATTS)
 WB : WET-BULB TEMPERATURE
 CFM : CU. FT. PER MINUTE

Performance data

50BF040

Gross Cooling Capacity Tables

Cond. Leaving Water Temp. (°F)		EVAP. Air Flow (CFM)								
		8,900			12,800			16,300		
		EVAP. Entering Air Temperature DB/WB (°F)								
		84/71	80/67	76/63	84/71	80/67	76/63	84/71	80/67	76/63
95	TC	461,300	425,600	391,900	489,300	450,600	414,500	509,100	469,800	433,700
	SHC	302,200	316,200	320,100	332,400	332,700	325,800	352,000	344,500	327,500
	KW	32.3	31.1	30.2	33.1	32.0	30.9	33.7	32.6	31.4
100	TC	452,600	416,700	383,400	478,100	439,100	405,300	496,000	458,600	422,700
	SHC	295,800	308,800	312,200	323,800	324,700	317,000	344,100	335,900	317,800
	KW	34.4	33.1	31.9	35.5	33.9	32.7	35.9	34.6	33.3
105	TC	443,800	407,800	374,800	466,800	427,600	396,100	482,800	447,400	411,700
	SHC	289,400	301,400	304,300	315,200	316,700	308,100	336,200	327,400	308,100
	KW	36.4	35.1	33.6	37.9	35.9	34.5	38.1	36.6	35.1

50BF050-1

Gross Cooling Capacity Tables

Cond. Leaving Water Temp. (°F)		EVAP. Air Flow (CFM)								
		12,700			15,000			19,000		
		EVAP. Entering Air Temperature DB/WB (°F)								
		84/71	80/67	76/63	84/71	80/67	76/63	84/71	80/67	76/63
95	TC	572,300	526,600	487,800	592,400	546,600	505,300	622,900	573,800	531,500
	SHC	351,100	349,900	337,700	370,200	361,700	341,200	399,500	378,000	343,500
	KW	34.0	33.3	32.5	34.2	33.6	32.8	34.6	34.0	33.3
100	TC	559,400	515,600	476,800	597,200	534,000	492,700	606,000	560,600	518,300
	SHC	343,600	341,300	328,500	362,300	352,500	332,200	390,800	367,900	332,600
	KW	35.4	34.6	33.7	35.6	34.9	34.1	36.1	35.4	34.6
105	TC	546,400	504,600	465,800	566,100	521,400	480,100	589,000	547,400	505,000
	SHC	336,200	332,700	319,300	354,300	343,300	323,300	382,000	357,800	321,700
	KW	36.7	35.8	34.9	37.0	36.2	35.4	37.6	36.7	35.8

50BF060-1

Gross Cooling Capacity Tables

Cond. Leaving Water Temp. (°F)		EVAP. Air Flow (CFM)								
		15,200			20,000			22,800		
		EVAP. Entering Air Temperature DB/WB (°F)								
		84/71	80/67	76/63	84/71	80/67	76/63	84/71	80/67	76/63
95	TC	689,900	637,100	587,700	732,300	676,100	625,800	752,700	696,400	643,600
	SHC	423,200	424,100	408,400	462,500	446,300	418,400	483,100	459,200	419,000
	KW	46.7	45.1	43.5	47.9	46.3	44.8	48.4	46.8	45.3
100	TC	674,500	621,700	574,300	714,900	660,100	610,300	735,100	678,900	627,900
	SHC	414,500	413,100	397,400	452,700	434,700	405,300	472,600	446,000	406,700
	KW	49.0	47.3	45.7	50.2	48.5	46.9	50.7	49.1	47.5
105	TC	659,100	606,300	560,900	697,500	644,200	594,900	717,500	661,300	612,300
	SHC	405,800	402,100	386,400	443,000	423,100	392,200	462,100	432,800	393,500
	KW	51.2	49.5	47.8	52.5	50.7	49.0	53.0	51.3	49.6

TC : TOTAL CAPACITY (BTUH)
 SHC : SENSIBLE HEAT CAPACITY (BTUH)
 DB : DRY-BULB TEMPERATURE

KW : COMPRESSOR MOTOR POWER INPUT (KILOWATTS)
 WB : WET-BULB TEMPERATURE
 CFM : CU. FT. PER MINUTE

Performance data

50BF080-1

Gross Cooling Capacity Tables

Cond. Leaving Water Temp. (°F)		EVAP. Air Flow (CFM)								
		20,500			25,500			30,500		
		EVAP. Entering Air Temperature DB/WB (°F)								
		84/71	80/67	76/63	84/71	80/67	76/63	84/71	80/67	76/63
95	TC	919,600	848,900	781,800	973,000	895,500	824,900	1,012,000	934,500	860,400
	SHC	567,100	561,600	542,300	612,500	593,600	557,500	649,700	614,100	561,300
	KW	63.8	61.6	59.6	65.4	63.1	60.9	66.6	64.2	62.0
100	TC	899,600	829,100	764,000	949,300	875,700	807,100	985,800	910,300	840,200
	SHC	556,000	550,400	529,100	599,000	578,100	540,100	636,200	598,600	543,800
	KW	67.9	65.4	63.0	69.7	67.0	64.5	70.9	68.2	65.7
105	TC	879,700	809,300	746,100	925,600	855,800	789,200	959,700	886,200	819,900
	SHC	544,900	539,200	516,000	585,400	562,600	522,700	622,700	583,100	526,400
	KW	72.0	69.1	66.4	73.9	70.9	68.1	75.3	72.2	69.4

TC : TOTAL CAPACITY (BTUH)
SHC : SENSIBLE HEAT CAPACITY (BTUH)
DB : DRY-BULB TEMPERATURE

KW : COMPRESSOR MOTOR POWER INPUT (KILOWATTS)
WB : WET-BULB TEMPERATURE
CFM : CU. FT. PER MINUTE

Water pressure drop thru condensers (PSI)

Model	Total Water Flow (GPM)																
	20	25	50	80	100	130	160	190	220	250	280	310	340	370	400	430	460
50BF008	3.3	4.7	-	-	-	-	-	-	-	-	-	-	-	-	-	-	-
50BF010	1.8	2.5	-	-	-	-	-	-	-	-	-	-	-	-	-	-	-
50BF015	-	0.7	1.9	-	-	-	-	-	-	-	-	-	-	-	-	-	-
50BF020	-	0.5	1.5	-	-	-	-	-	-	-	-	-	-	-	-	-	-
50BF025	-	1.0	3.0	6.8	-	-	-	-	-	-	-	-	-	-	-	-	-
50BF030	-	0.8	2.1	4.7	-	-	-	-	-	-	-	-	-	-	-	-	-
50BF040	-	-	-	0.7	1.4	2.2	3.0	4.0	5.1	-	-	-	-	-	-	-	-
50BF050-1	-	-	0.9	1.4	2.2	3.5	4.8	6.8	-	-	-	-	-	-	-	-	-
50BF060-1	-	-	-	1.4	2.3	3.6	4.8	6.4	8.4	10.5	-	-	-	-	-	-	-
50BF080-1	-	-	-	-	-	0.8	1.0	1.3	1.7	2.0	2.4	2.8	3.3	4.0	4.5	5.2	-

Electrical data

Unit Model	Nominal Voltage	Voltage Range		Compressor			Indoor Fan Motor			Power Wire (sq.mm.)	Ground Wire (sq.mm.)	Recommended field CB (AT)
		Min	Max	RLA	LRA	QTY	kW	RLA				
50BF008SC	380V/3Ph/50Hz	360	440	1 ... 14	1 ... 111	1	0.75	1.8	6	2.5	25	
50BF010SC	380V/3Ph/50Hz	360	440	1 ... 19	1 ... 153	1	1.50	3.3	10	4	35	
50BF015SC	380V/3Ph/50Hz	360	440	1 ... 27	1 ... 174	1	2.20	4.7	16	6	50	
50BF020SC	380V/3Ph/50Hz	360	440	2 ... 16	2 ... 118	1	3.70	8.0	25	6	60	
50BF020	380V/3Ph/50Hz	360	440	1 ... 44	1 ... 153	1	3.70	8.0	25	6	60	
50BF025SC	380V/3Ph/50Hz	360	440	2 ... 18	2 ... 118	1	3.70	8.0	25	6	60	
50BF025	380V/3Ph/50Hz	360	440	1 ... 44	1 ... 153	1	3.70	8.0	25	6	60	
50BF030SC	380V/3Ph/50Hz	360	440	2 ... 27	2 ... 174	1	5.50	11.5	35	10	80	
50BF030	380V/3Ph/50Hz	360	440	1 ... 58	1 ... 210	1	5.50	11.5	35	10	80	
50BF040SC	380V/3Ph/50Hz	360	440	2 ... 30	2 ... 225	1	7.50	14.0	35	10	80	
50BF040	380V/3Ph/50Hz	360	440	1 ... 97	1 ... 307	1	7.50	14.0	50	10	100	
50BF050SC-1	380V/3Ph/50Hz	360	440	2 ... 44	2 ... 153	1	7.50	14.0	50	10	100	
50BF050-1	380V/3Ph/50Hz	360	440	2 ... 44	2 ... 153	1	7.50	14.0	50	10	100	
50BF060SC-1	380V/3Ph/50Hz	360	440	2 ... 58	2 ... 210	1	11.00	21.6	95	16	150	
50BF060-1	380V/3Ph/50Hz	360	440	2 ... 58	2 ... 210	1	11.00	21.6	95	16	150	
50BF080-1	380V/3Ph/50Hz	360	440	2 ... 97	2 ... 307	1	15.00	28.3	150	16	200	

Note:

Unit 50BF050-50BF080 have 2 compressors. Values are for each compressor.

FLA : Full Load Amps

RLA : Rated Load Amps

LRA : Locked Rotor Amps

MOCP: Maximum Overcurrent Protective Device

BASE UNIT

UNIT shall be single-package vertical type and shall include self contained water cooled condenser(s).

Units shall be similar to the Carrier 50BF range.

TOTAL COOLING CAPACITY of the unit shall be ___ Btuh or greater at conditions of ___ cfm. Evaporator air entering at ___ °F wet bulb temperature. Total sensible capacity shall be Btuh or greater with ___ °F dry bulb temperature at the above conditions.

WATER COOLED CONDENSER(S) shall maintain ___ °F saturated condensing temperature when supplied with ___ GPM. of ___ water at a ft^2 - hr - F/BTU water fouling factor.

MAXIMUM WATER PRESSURE DROP for the condenser(s) all these conditions shall be ___ IN. of water. Unit(s) of nominal 187,600 Btuh or greater cooling capacity shall be provided with 2 steps of cooling capacity.

CABINET shall be of heavy gauge galvanized steel, phosphatised and powder painted. Unit sections shall be insulated to prevent sweating and to muffle sound using 1 IN. thick rockwool covered with aluminium foil. The unit dimensions shall be ___ mm wide, ___ mm deep and ___ mm high. A self contained filter frame for use of standard throwaway or permanent filters of ___ x ___ x ___ IN shall be located inside the cabinet.

CONDENSERS

WATER COOLED CONDENSERS shall be shell and tube type for all units of 50BF series. Each shall be equipped with a pressure relief device and liquid line shut off valve. Tubes shall be seamless with no interior joints. Threaded pipe connections shall be provided for water supply and return lines. Each unit shall contain a full operating refrigerant charge. **CONTROLS** shall be factory wired to operate on ___ volts, 1 phase, ___ Hz power supply. A factory mounted multi position switch shall control the unit for continuous fan and cooling operation. Circuit breakers or overload relay shall be factory installed. Compressor protection shall include high and low pressure switched and inherent over temperature protection (units ___ thru ___).

EVAPORATOR COILS shall be of non-ferrous construction with copper tubing and shall be fed by capillary tube for 50BF008, 50BF010 and thermostatic expansion valve(s) for 50BF015 to 50BF080. Coils shall be of the same manufacture as unit.

EVAPORATOR AIR FAN(S) shall be capable of delivering ___ cfm. of air with an external static pressure of ___ in. Evaporator air fans shall be centrifugal forward curved and belt driven by a TEFC induction motor of nominal ___ KW or less when operating at ___ rpm.



TT Air Engineering

บริษัท แครีเยอร์ (ประเทศไทย) จำกัด

1858/63-74 ชั้น 14,15
ถ.บางนา-ตราด กม. 4.5
บางนา กรุงเทพฯ 10260
โทร. 0-2090-9999 แฟกซ์: 0-2751-4778

Carrier (Thailand) Ltd.

1858/63-74, 14th, 15th Floor,
Bangna-Trad Road, Km. 4.5,
Bangna, Bangkok 10260 Thailand
Tel. 0-2090-9999 Fax: 0-2751-4778

Carrier reserves the right to make changes in specifications without prior notice.
บริษัทฯ ขอสงวนสิทธิ์ที่จะเปลี่ยนแปลงรายละเอียดข้างต้น โดยไม่ต้องแจ้งให้ทราบล่วงหน้า



YOUR CARRIER MAN :

50BF/05/2024