



1135451001

## VRF DX COIL INTERFACE



### MODEL NAME

For commercial use

#### Dx-coil controller

**40VAM--C8FATEE**

(Terminal block without relay)

**40VAMR-C8FATEE**

(Terminal block with relay)

#### Dx-valve kit

**40VA010V8-ATEE**

**40VA020V8-ATEE**

# Installation Manual

Notice: *Carrier* is committed to continuously improving its products to ensure the highest quality and reliability standards, and to meet local regulations and market requirements. All features and specifications are subject to change without prior notice.

English



Please read this Installation Manual carefully before installing the Air Conditioner.

- This Manual describes the installation method of the **VRF DX COIL INTERFACE**.
- For installation of the air handling unit, follow the Installation Manual attached to the air handling unit. (Field supply)
- For installation of the outdoor unit, follow the Installation Manual attached to the outdoor unit.
- Carrier does not take any responsibility on the local design.

## ADOPTION OF R410A REFRIGERANT

This Air Conditioner uses R410A an environmentally friendly refrigerant.

# Contents

<b>1.</b>	<b>Precautions .....</b>	<b>3</b>
<b>2.</b>	<b>Overview.....</b>	<b>7</b>
<b>3.</b>	<b>Accessories.....</b>	<b>13</b>
<b>4.</b>	<b>Installation.....</b>	<b>14</b>
	<b>Installation Dx-valve kit (Refrigerant pipe).....</b>	<b>16</b>
	<b>Installation Dx-coil controller (Electrical wiring, DN setting).....</b>	<b>21</b>
<b>5.</b>	<b>Test run.....</b>	<b>41</b>
<b>6.</b>	<b>Trouble shooting.....</b>	<b>42</b>

### Definition of Protective Gear

- When the VRF DX COIL INTERFACE is to be transported, installed, maintained, repaired or removed, wear protective gloves and “Safety” work clothing.
- In addition to such normal protective gear, wear the protective gear described below when undertaking the special work detailed in the following table.
- Failure to wear the proper protective gear is dangerous because you will be more susceptible to injury, burns, electric shocks and other injuries.

Work undertaken	Protective gear to wear
All types of work	Protective gloves “Safety” working clothing
Electrical-related work	Gloves to provide protection from electric shock Insulating shoes Clothing to provide protection from electric shock
Work done at heights (50 cm or more)	Helmets for use in industry
Transportation of heavy objects	Shoes with additional protective toe cap
Repair	Gloves to provide protection for electricians

## ■ Warning indications on the Dx-coil interface unit

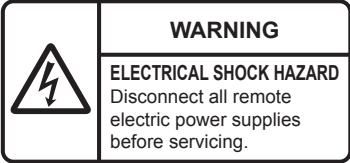
Warning indication	Description
	<p><b>WARNING</b></p> <p><b>ELECTRICAL SHOCK HAZARD</b> Disconnect all remote electric power supplies before servicing.</p>

### Definition of Qualified Installer or Qualified Service Person

The air conditioner must be installed, maintained, repaired and removed by a qualified installer or qualified service person. When any of these jobs is to be done, ask a qualified installer or qualified service person to do them. A qualified installer or qualified service person is an agent who has the qualifications and knowledge described in the following table.

Agent	Qualifications and knowledge which the agent must have
Qualified installer	<ul style="list-style-type: none"> <li>• The qualified installer is a person who installs, maintains, relocates and removes the air conditioners made by Manufacturer. He or she has been trained to install, maintain, relocate and remove the air conditioners made by Manufacturer or, alternatively, he or she has been instructed in such operations by an individual or individuals who have been trained and is thus thoroughly acquainted with the knowledge related to these operations.</li> <li>• The qualified installer who is allowed to do the electrical work involved in installation, relocation and removal has the qualifications pertaining to this electrical work as stipulated by the local laws and regulations, and he or she is a person who has been trained in matters relating to electrical work on the air conditioners made by Manufacturer or, alternatively, he or she has been instructed in such matters by an individual or individuals who have been trained and is thus thoroughly acquainted with the knowledge related to this work.</li> <li>• The qualified installer who is allowed to do the refrigerant handling and piping work involved in installation, relocation and removal has the qualifications pertaining to this refrigerant handling and piping work as stipulated by the local laws and regulations, and he or she is a person who has been trained in matters relating to refrigerant handling and piping work on the air conditioners made by Manufacturer or, alternatively, he or she has been instructed in such matters by an individual or individuals who have been trained and is thus thoroughly acquainted with the knowledge related to this work.</li> <li>• The qualified installer who is allowed to work at heights has been trained in matters relating to working at heights with the air conditioners made by Manufacturer or, alternatively, he or she has been instructed in such matters by an individual or individuals who have been trained and is thus thoroughly acquainted with the knowledge related to this work.</li> </ul>
Qualified service person	<ul style="list-style-type: none"> <li>• The qualified service person is a person who installs, repairs, maintains, relocates and removes the air conditioners made by Manufacturer. He or she has been trained to install, repair, maintain, relocate and remove the air conditioners made by Manufacturer or, alternatively, he or she has been instructed in such operations by an individual or individuals who have been trained and is thus thoroughly acquainted with the knowledge related to these operations.</li> <li>• The qualified service person who is allowed to do the electrical work involved in installation, repair, relocation and removal has the qualifications pertaining to this electrical work as stipulated by the local laws and regulations, and he or she is a person who has been trained in matters relating to electrical work on the air conditioners made by Manufacturer or, alternatively, he or she has been instructed in such matters by an individual or individuals who have been trained and is thus thoroughly acquainted with the knowledge related to this work.</li> <li>• The qualified service person who is allowed to do the refrigerant handling and piping work involved in installation, repair, relocation and removal has the qualifications pertaining to this refrigerant handling and piping work as stipulated by the local laws and regulations, and he or she is a person who has been trained in matters relating to refrigerant handling and piping work on the air conditioners made by Manufacturer or, alternatively, he or she has been instructed in such matters by an individual or individuals who have been trained and is thus thoroughly acquainted with the knowledge related to this work.</li> <li>• The qualified service person who is allowed to work at heights has been trained in matters relating to working at heights with the air conditioners made by Manufacturer or, alternatively, he or she has been instructed in such matters by an individual or individuals who have been trained and is thus thoroughly acquainted with the knowledge related to this work.</li> </ul>

# 1. Precautions

The manufacturer shall not assume any liability for the damage caused by not observing the description of this manual.

## **WARNING**

---

### **General**

- Do not modify the products. Do not also disassemble or modify the parts. It may cause a fire, electric shock or injury.
- Before starting to install the Dx-coil interface, read through the Installation Manual carefully, and follow its instructions to install the Dx-coil interface.
- Only a qualified installer or qualified service person is allowed to do installation work. Inappropriate installation may result in water leakage, electric shock or fire.
- Do not use any refrigerant different from the one specified for complement or replacement. Otherwise, abnormally high pressure may be generated in the refrigeration cycle, which may result in a failure or explosion of the product or an injury to your body.
- Before opening the electrical control box cover of the air handling unit or service panel of the outdoor unit, set the circuit breaker to the OFF position. Failure to set the circuit breaker to the OFF position may result in electric shocks through contact with the interior parts. Only a qualified installer (\*1) or qualified service person (\*1) is allowed to remove the electrical control box cover of the air handling unit or service panel of the outdoor unit and do the work required.
- Before carrying out the installation, maintenance, repair or removal work, set the circuit breaker to the OFF position. Otherwise, electric shocks may result.
- Place a “Work in progress” sign near the circuit breaker while the installation, maintenance, repair or removal work is being carried out. There is a danger of electric shocks if the circuit breaker is set to ON by mistake.
- Only a qualified installer (\*1) or qualified service person (\*1) is allowed to undertake work at heights using a stand of 50 cm or more.
- Wear protective gloves and safety work clothing during installation, servicing and removal.
- When work is performed at heights, use a ladder which complies with the ISO 14122 standard, and follow the procedure in the ladder’s instructions. Also wear a helmet for use in industry as protective gear to undertake the work.
- Before working at heights, put a sign in place so that no-one will approach the work location, before proceeding with the work. Parts and other objects may fall from above, possibly injuring a person below. While carrying out the work, wear a helmet for protection from falling objects.
- The refrigerant used by this Dx-coil interface is the R410A.
- The Dx-coil interface must be transported in stable condition. If any part of the product is broken, contact the dealer.
- Do not move or repair any unit by yourself. There is high voltage inside the unit. You may get electric shock when removing the cover and main unit.
- This appliance is intended to be used by expert or trained users in shops, in light industry, or for commercial use by lay persons.
- Do not add any other devices without factory advice.

### **Installation**

- Install the air conditioner securely in a location where the base can sustain the weight adequately. If the strength is not enough, the unit may fall down resulting in injury.
- Follow the instructions in the Installation Manual to install the air conditioner. Failure to follow these instructions may cause the product to fall down or topple over or give rise to noise, vibration, water leakage or other trouble.
- Carry out the specified installation work to guard against the possibility of high winds and earthquake.

If the air conditioner is not installed appropriately, a unit may topple over or fall down, causing an accident.



- If refrigerant gas has leaked during the installation work, ventilate the room immediately. If the leaked refrigerant gas comes in contact with fire, noxious gas may generate.
- Helmet must be worn to protect your head from falling objects. Especially, when you work under an inspection opening, helmet must be worn to protect your head from falling objects from the opening.

### **Selection of installation location**

- When the air conditioner is installed in a small room, provide appropriate measures to ensure that the concentration of refrigerant leakage occur in the room does not exceed the critical level.
- Do not install in a location where flammable gas leaks are possible. If the gas leak and accumulate around the unit, it may ignite and cause a fire.
- To transport the Dx-coil interface, wear shoes with additional protective toe caps.
- Do not place any combustion appliance in a place where it is directly exposed to the wind of air conditioner, otherwise it may cause imperfect combustion.

### **Refrigerant piping**

- Install the refrigerant pipe securely during the installation work before operating the air conditioner. If the compressor is operated with the valve open and without refrigerant pipe, the compressor sucks air and the refrigeration cycles is over pressurized, which may cause a injury.
- After the installation work, confirm that refrigerant gas does not leak. If refrigerant gas leaks into the room and flows near a fire source, such as a cooking range, noxious gas may be generated.
- When the air conditioner has been installed or relocated, follow the instructions in the Installation Manual and purge the air completely so that no gases other than the refrigerant will be mixed in the refrigerating cycle. Failure to purge the air completely may cause the air conditioner to malfunction.
- Nitrogen gas must be used for the airtight test.
- The charge hose must be connected in such a way that it is not slack.
- Due to the pressure of R410A is higher than that of other refrigerant (ex. R22), be sure to use the pipe specific for R410A and use the special tool for the pipe processing.

### **Electrical wiring**

- Only a qualified installer (\*1) or qualified service person (\*1) is allowed to carry out the electrical work of the air conditioner. Under no circumstances must this work be done by an unqualified individual since failure to carry out the work properly may result in electric shocks and/or electrical leaks.
- To connect the electrical wires, repair the electrical parts or undertake other electrical jobs, wear gloves to provide protection for electricians, insulating shoes and clothing to provide protection from electric shocks. Failure to wear this protective gear may result in electric shocks.
- Use wiring that meets the specifications in the Installation Manual and the stipulations in the local regulations and laws. Use of wiring which does not meet the specifications may give rise to electric shocks, electrical leakage, smoking and/or a fire.
- Connect earth wire. (Grounding work) Incomplete grounding causes an electric shock.
- Do not connect earth wires to gas pipes, water pipes, and lightning conductor or telephone earth wires.
- After completing the repair or relocation work, check that the earth wires are connected properly.
- Install a circuit breaker that meets the specifications in the Installation Manual and the stipulations in the local regulations and laws.
- Install the circuit breaker where it can be easily accessed by the agent.
- When installing the circuit breaker outdoors, install one which is designed to be used outdoors.



- Under no circumstances the power wire must not be extended. Connection trouble in the places where the wire is extended may give rise to smoking and/or a fire.
- Electrical wiring work shall be conducted according to law and regulation in the community and Installation Manual. Failure to do so may result in electrocution or short circuit.
- Make sure that the circuit breaker is attached. If it is not, the electric shock may be caused.
- Do not use the fuse other than the correct capacity. Use of wire or copper wire may result in fire or malfunction.
- Ensure that the power is the rated voltage and use the circuit special for the Dx-coil interface.

### **Test run**

- Before operating the air conditioner after having completed the work, check that the electrical control box cover of the air handling unit and service panel of the outdoor unit are closed, and set the circuit breaker to the ON position. You may receive an electric shock if the power is turned on without first conducting these checks.
- If there is any kind of trouble (such as a check display has appeared, smell of burning, abnormal sounds, the air conditioner fails to cool or heat or water is leaking) has occurred in the air conditioner, do not touch the air conditioner yourself but set the circuit breaker to the OFF position, and contact a qualified service person. Take steps to ensure that the power will not be turned on (by marking “out of service” near the circuit breaker, for instance) until qualified service person arrives. Continuing to use the air conditioner in the trouble status may cause mechanical problems to escalate or result in electric shocks or other trouble.
- After the work has finished, use an insulation tester set (500 VMΩ) to check the resistance is 1 MΩ or more between the charge section and the non-charge metal section (Earth section). If the resistance value is low, a disaster such as a leak or electric shock is caused at user’s side.
- Upon completion of the installation work, check for refrigerant leaks and check the insulation resistance and water drainage. Then conduct a test run to check that the air conditioner is operating properly.

### **Explanations given to user**

- Upon completion of the installation work, tell the user where the circuit breaker is located. If the user does not know where the circuit breaker is, he or she will not be able to turn it off in the event that trouble has occurred in the air conditioner.
- After the installation work, follow the Owner’s Manual to explain to the customer how to use and maintain the unit.

### **Relocation**

- Only a qualified installer (\*1) or qualified service person (\*1) is allowed to relocate the air conditioner. It is dangerous for the air conditioner to be relocated by an unqualified individual since a fire, electric shocks, injury, water leakage, noise and/or vibration may result.
- When carrying out the pump-down work shut down the compressor before disconnecting the refrigerant pipe. Disconnecting the refrigerant pipe with the service valve left open and the compressor still operating will cause air or other gas to be sucked in, raising the pressure inside the refrigeration cycle to an abnormally high level, and possibly resulting in rupture, injury or other trouble.

### **Repair • Maintenance**

- Request the repair to the distributor that you made your purchase from.
- If there is a defect in the repair, the fire, electric shock may be caused.
- Turn off the circuit breaker of the entire system including the AHU and the outdoor unit when performing the repair or the maintenance.

---

(\*1) Refer to the “Definition of Qualified Installer or Qualified Service Person”.

## ■ Selection of installation place

---

### Avoid installation in the following kinds of locations.

- Dx-coil interface is recommended to be installed indoors. Install it in a location where there is no rain, wind, and direct sunlight.
- Do not install in locations where there is a machine generating high frequency. Failure to do so may cause a wrong operation or an abnormality.
- Do not install in locations with atmospheres with mist of oil (including machine oil) or dense vapor, or locations containing salt such as the coast area, or locations with acidic or alkaline atmospheres, or locations where sulfurizing gas are generated such as areas with hot springs. Use in inappropriate locations result in malfunctions.
- Do not put any vessel contains the water in the vicinity of the indoor unit (including Dx-coil controller, Dx-valve kit).  
If the water spills and enters into the inside of the unit, the electric insulation deteriorates and may result in an electric shock.
- Make sure that the air filter is attached on the indoor unit. If it is not, the dust clogs in the heat exchanger etc. in the air conditioner and may result in water leakage or defrosting.
- Separate the television or radio from the air conditioner or remote controller at least 1 m. Failure to do so may cause the disturbance of the image, or the noise.
- Do not use for special-purpose (Foods, animals and plants, precision machine, storage of the artwork etc.).
- Do not use in locations where there is anything that would be compromised by wetness. The mist or water dew drop may result in damage.
- Do not install in locations where organic solvents are being used.
- Do not install in locations near doors or windows where the air conditioner may come into contact with high humidity outside air. Condensation may occur as a result.
- Do not install in locations where special sprays are used frequently. The location has an impact on the insulation of the equipment and may cause the ignition.
- Do not install in locations with high-humidity atmosphere. Doing so may cause condensation of the equipment, splashing of water from the air outlet side of indoor unit.  
Ex. 1) Installation to inside of the ceiling where is high humidity.  
2) Installation to inside of the ceiling used for the path of the fresh air intake.  
3) Installation to a kitchen.
- In the above cases, additionally attach the heat insulator (grass wool etc.) to all positions of the air conditioner, which come to contact with the high-humidity atmosphere.  
\* The guideline of the high-humidity condition is “dew-point temperature: 23°C or higher”, however, the decision should be made according to the trial operation conducted in each installation location.
- Install in locations that ensure the sufficient space needed for the service so that the equipment does not come to contact with the surface of the wall or the ceiling.
- Fix the Dx-coil controller, Dx-valve kit to the stable surface. Failure to do so may cause the vibration or the noise.
- Do not install the Dx-coil controller, Dx-valve kit to the locations where there is a temperature difference with the ambient temperature. Failure to do so may result in condensation, rust, or malfunction. Ex. The sheet metal side surface of the AHU outlet.
- Install the Dx-valve kit to where the noise is no problem due to the Dx-valve kit makes the refrigerant noise. Also, it may make the refrigerant noise when other indoor units are operating even if the AHU is stopping like defrosting.
- Do not install in locations with the high temperature or the high-humidity atmosphere of 52°C or more / RH 80% or more. Also, do not install it in a place where dew condensation occurs inside the Dx-coil controller.
- When installing the Dx-valve kit and the Dx-coil controller into the Air handling unit, do not install it where it is exposed to the cooled air of the secondary side of the heat exchanger.
- Do not install in locations where iron or other metal dust is present. If iron or other metal dust adheres to or collects on the interior of the Dx-coil controller, it may spontaneously combusted and start a fire.

## 2. Overview

VRF Dx-coil interface is the product that is used with connecting the AHU with the DX COIL prepared on-site to the Carrier VRF outdoor unit.

- \* 1. DX COIL: Abbreviation of the Direct expansion coil (heat exchanger).
- \* 2. DDC: Abbreviation of the Direct Digital Controller.
- \* 3. AHU: Abbreviation of the Air Handling Unit.

For the installation of the air handling unit, refer to the Installation Manual of the air handling unit.

- Dx-coil interface (DDC type use for Supply air temperature or TF type) cannot control the room temperature.

### ■ Example of the system configuration

VRF Dx-coil interface can connect to New Carrier band VRF.

In one cycle the outdoor unit and Dx-coil interface shall be one each for the structure.

For the AHU prepared on-site, please design with referring to submittal of AHU.

**TA type** : Enables to connect 3rd party indoor unit or air handling unit as one of VRF indoor unit.  
 (Return air temperature control by remote controller setting)  
 Main application target – Room temperature conditioning

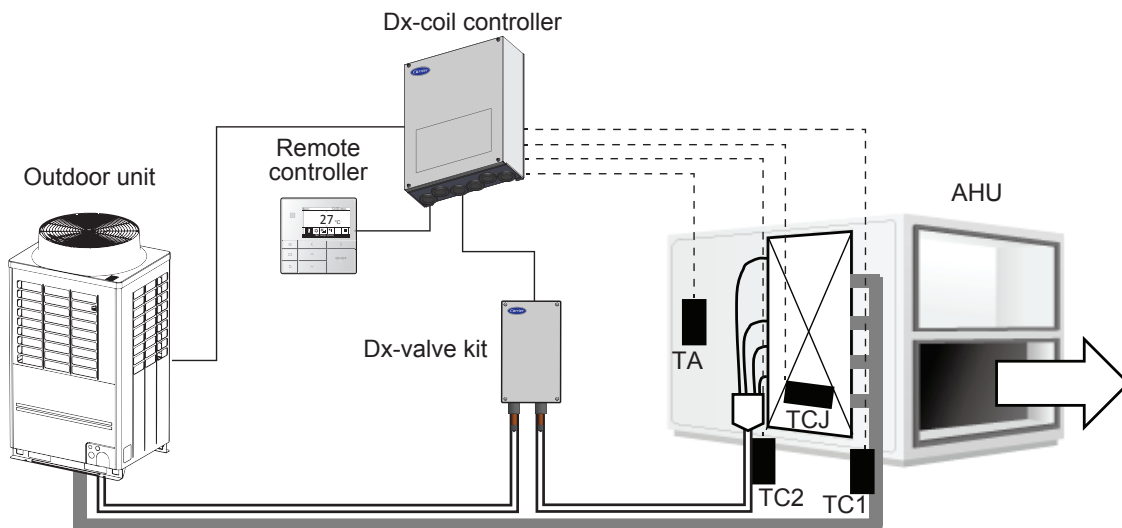
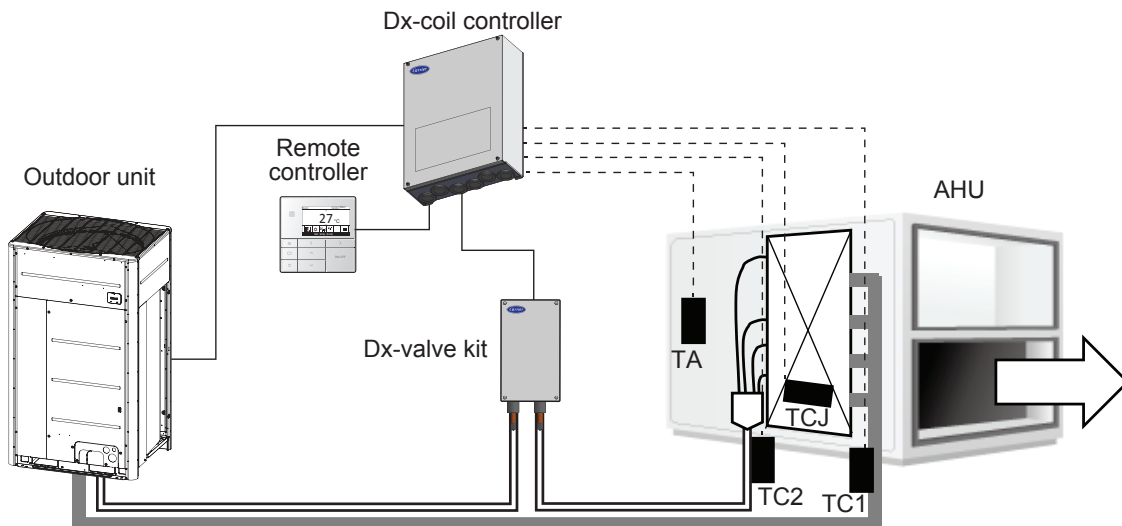



**TF type** : The discharge temperature is set by the remote controller to control the capacity.  
 Main application target – Ventilation

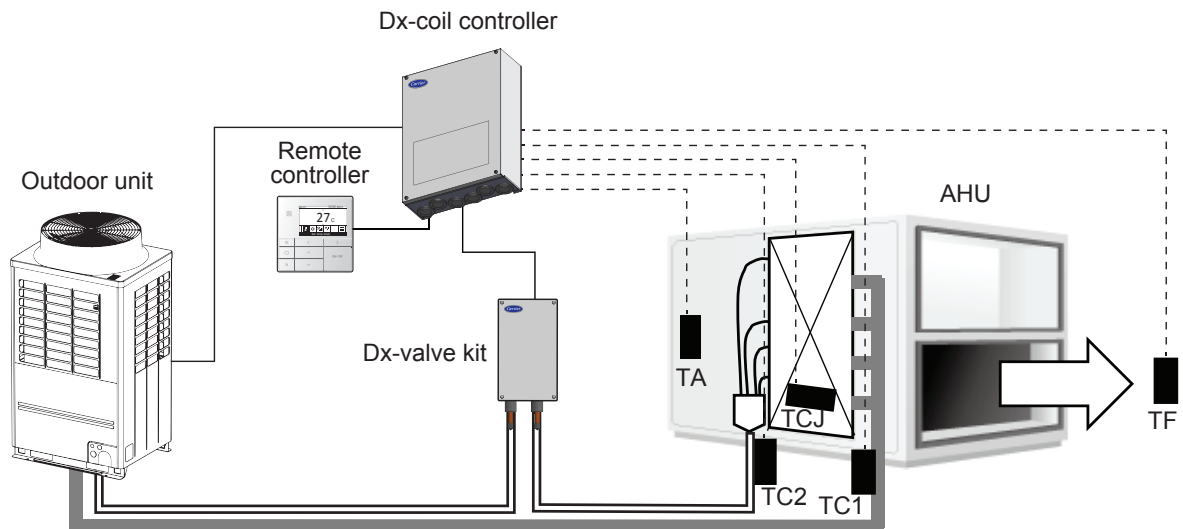
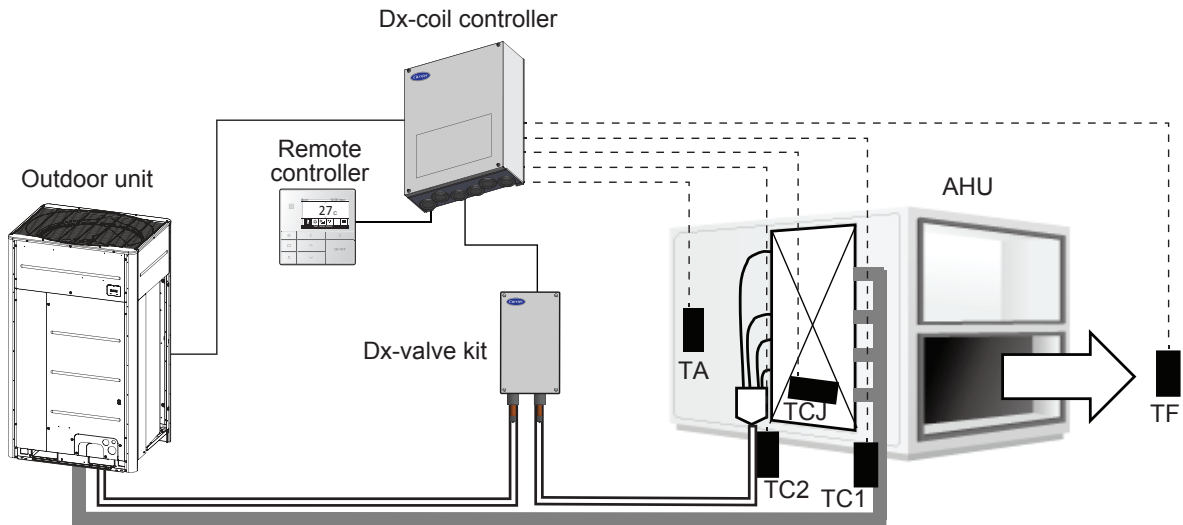

**DDC type** : Direct capacity control of Carrier VRF outdoor unit by analogue input (0-10 V)  
 Mainly discharge air temperature control linked AHU system.

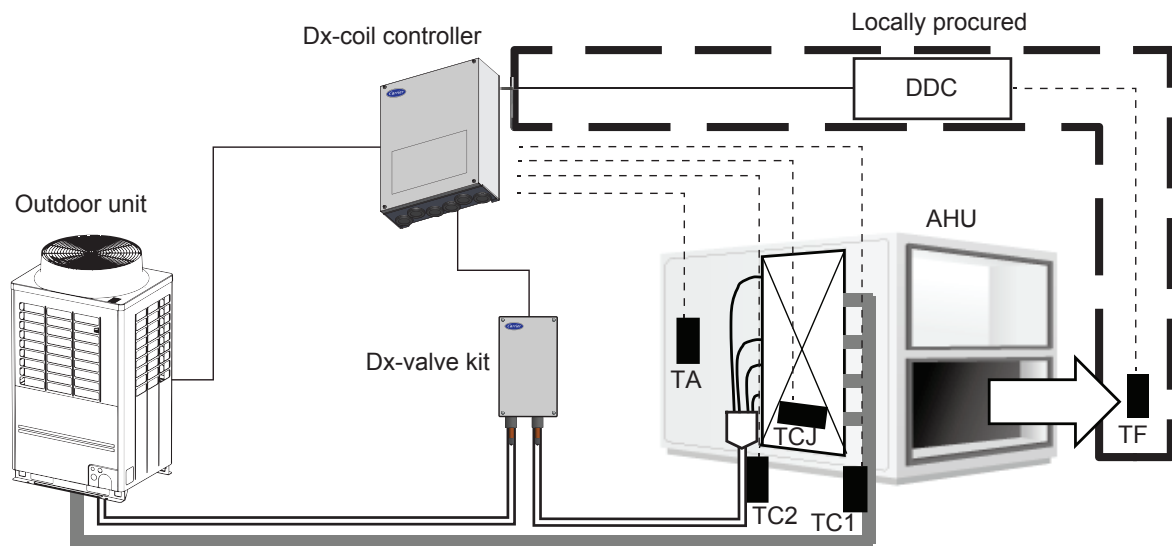
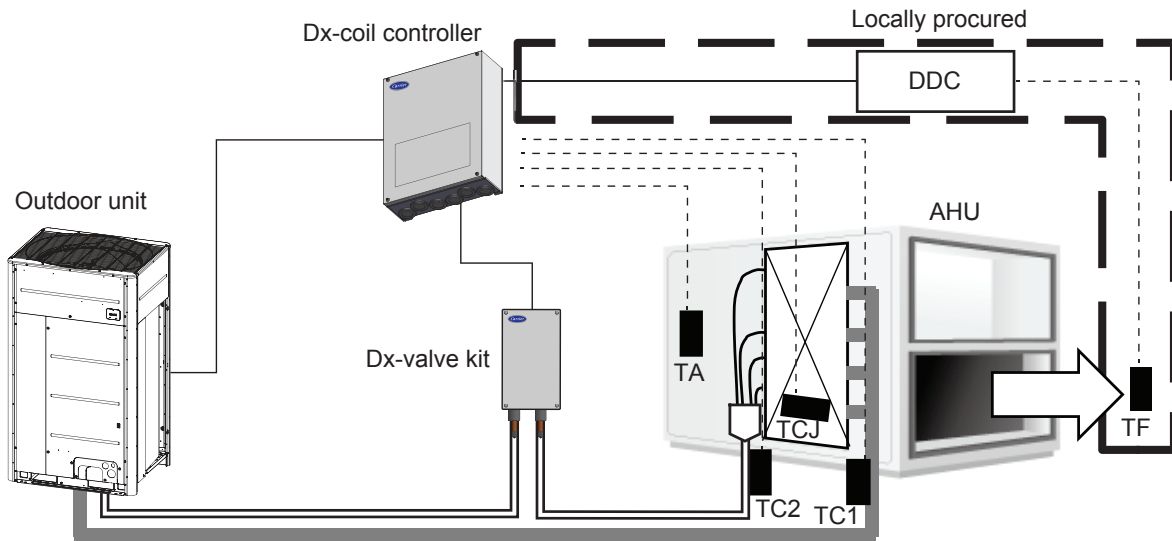

• Diversity specification

Type	38VT***
(communication)	(TU2C-LINK or TCC LINK)
TA type	○60 - 110%
DDC type	○75 - 100%
TF type	○80 - 100%

- Two or more AHU below 12 HP combination is available.
- Two or more AHU over 14 HP combination is available.
- Combination AHU below 12 HP with VRF FCU below 10 HP is available.
- Combination AHU over 14 HP with VRF FCU is prohibited.
- For the AHU prepared on-site, please design with referring to submittal of AHU.  
 Please refer to the design guideline for details.

DX COIL type	Normal	Split face	Interlaced	Split Row
Max. connectable Dx-coil capacity	UP to 40 HP	Not Available	Not Available	Not Available
Specification	1 inlet & outlet port	2 or 3 inlet & outlet ports 2 or 3 path ways are arranged up and down	2 or 3 inlet & outlet ports 2 or 3 path ways are interlaced	2 or 3 inlet & outlet ports 2 or 3 path ways are arranged parallels



DX COIL type		Normal				Interlaced, Split face			
Type		Dx-coil controller	Dx-valve kit		HEX number	Dx-coil controller	Dx-valve kit		HEX number
Model name		40VAM--C8FATEE 40VAMR-C8FATEE	40VA010V8 -ATEE	40VA020V8 -ATEE		40VAM--C8FATEE 40VAMR-C8FATEE	40VA010V8 -ATEE	40VA020V8 -ATEE	
Connectable Dx-coil capacity	8 HP	1	1	-	1				
	10 HP	1	1	-	1				
	12 HP	1	1	-	1				
	14 HP	1	-	1	1				
	16 HP	1	-	1	1	-	-	-	-
						2(8+8)	2	-	2
	18 HP	1	-	1	1	-	-	-	-
						2(8+10)	2	-	2
	20 HP	1	-	1	1	-	-	-	-
						2(10+10)	2	-	2
	22 HP	-	-	-	-	2(12+10)	2	-	2
	24 HP	1	2	-	1	2(12+12)	2	-	2
						3(8+8+8)	3	-	3
	26 HP	-	-	-	-	3(10+8+8)	3	-	3
	28 HP	1	-	2	1	2(14+14)	-	2	2
						3(10+10+8)	3	-	3
	30 HP	-	-	-	-	3(10+10+10)	3	-	3
32 HP	1	-	2	1	2(16+16)	-	2	2	
34 HP	-	-	-	-	2(18+16)	-	2	2	
36 HP	1	-	2	1	2(18+18)	-	2	2	
38 HP	-	-	-	-	2(20+18)	-	2	2	
40 HP	1	-	2	1	2(20+20)	-	2	2	



DX COIL type		Interlaced, Split face				Interlaced, Split face			
Type		Dx-coil controller	Dx-valve kit		HEX number	Dx-coil controller	Dx-valve kit		HEX number
Model name		40VAM--C8FATEE 40VAMR-C8FATEE	40VA010V8 -ATEE	40VA020V8 -ATEE		40VAM--C8FATEE 40VAMR-C8FATEE	40VA010V8 -ATEE	40VA020V8 -ATEE	
Connectable Dx-coil capacity	42 HP	-	-	-	-	3(14+14+14)	-	3	3
	44 HP	-	-	-	-	3(16+14+14)	-	3	3
	46 HP	-	-	-	-	3(16+16+14)	-	3	3
	48 HP	2(24+24)	4	-	2	3(16+16+16)	-	3	3
	50 HP	-	-	-	-	3(18+16+16)	-	3	3
	52 HP	-	-	-	-	3(18+18+16)	-	3	3
	54 HP	-	-	-	-	3(18+18+18)	-	3	3
	56 HP	2(28+28)	-	-	-	3(20+18+18)	-	3	3
				4	2	4(14+14+14+14)	-	4	4
	58 HP	-	-	-	-	3(20+20+18)	-	3	3
	60 HP	-	-	-	-	3(20+20+20)	-	3	3
	62 HP	-	-	-	-	4(16+16+16+14)	-	4	4
	64 HP	2(32+32)	-	4	2	4(16+16+16+16)	-	4	4
	66 HP	-	-	-	-	4(18+16+16+16)	-	4	4
	68 HP	-	-	-	-	4(18+18+16+16)	-	4	4
	70 HP	-	-	-	-	4(18+18+18+16)	-	4	4
	72 HP	2(36+36)	-	4	2	4(18+18+18+18)	-	4	4
	74 HP	-	-	-	-	4(20+18+18+18)	-	4	4
	76 HP	-	-	-	-	4(20+20+18+18)	-	4	4
	78 HP	-	-	-	-	4(20+20+20+18)	-	4	4
	80 HP	2(40+40)	-	4	2	4(20+20+20+20)	-	4	4
	82 HP	-	-	-	-	5(18+16+16+16+16)	-	5	5
	84 HP	3(28+28+28)	-	-	-	5(18+18+16+16+16)	-	6	5
				6	3	6(14+14+14+14+14+14)	-	6	6
	86 HP	-	-	-	-	5(18+18+18+16+16)	-	5	5
	88 HP	-	-	-	-	5(18+18+18+18+16)	-	5	5
	90 HP	-	-	-	-	5(18+18+18+18+18)	-	5	5
	92 HP	-	-	-	-	5(20+18+18+18+18)	-	5	5
	94 HP	-	-	-	-	5(20+20+18+18+18)	-	5	5
	96 HP	3(32+32+32)	-	-	-	5(20+20+20+18+18)	-	5	5
				6	3	6(16+16+16+16+16+16)	-	6	6
	98 HP	-	-	-	-	5(20+20+20+20+18)	-	5	5
	100 HP	-	-	-	-	5(20+20+20+20+20)	-	5	5
	102 HP	-	-	-	-	6(18+18+18+16+16+16)	-	6	6
	104 HP	-	-	-	-	6(18+18+18+18+16+16)	-	6	6
	106 HP	-	-	-	-	6(18+18+18+18+18+16)	-	6	6
108 HP	3(36+36+36)	-	6	3	6(18+18+18+18+18+18)	-	6	6	
110 HP	-	-	-	-	6(20+18+18+18+18+18)	-	6	6	
112 HP	-	-	-	-	6(20+20+18+18+18+18)	-	6	6	
114 HP	-	-	-	-	6(20+20+20+18+18+18)	-	6	6	
116 HP	-	-	-	-	6(20+20+20+20+18+18)	-	6	6	
118 HP	-	-	-	-	6(20+20+20+20+20+18)	-	6	6	
120 HP	3(40+40+40)	-	6	3	6(20+20+20+20+20+20)	-	6	6	

## ■ Settings for each type (TA, TF, DDC)

Set with the SW501 switch on the control P.C. board MCC-1777.

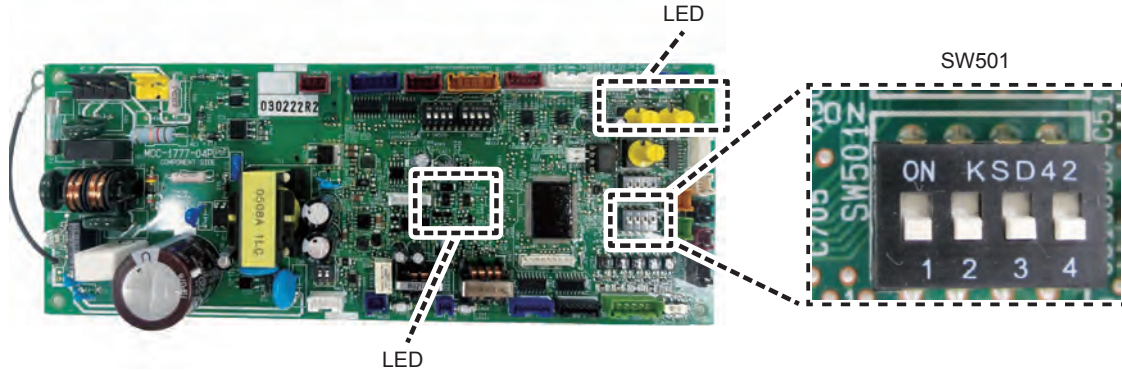

TA type: Set all SW501 to OFF.  
Turn off Bit3 of SW501.



TF type: Turn on only Bit2 of SW501.  
Turn off Bit3 of SW501.

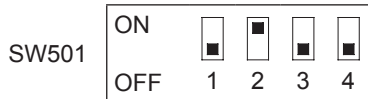

DDC type (0 - 10 V) Stepped Control: Turn on only Bit3 of SW501. (Refer to AI3 / \*AI3 for details)

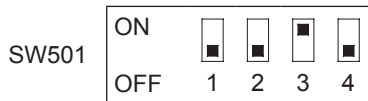

DDC type (0 - 10 V) Linear Control: Turn on Bit3 and Bit4 of SW501. (Refer to AI3 / \*AI3 for details)

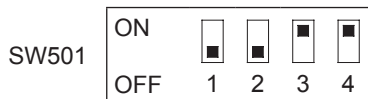

LED position and details

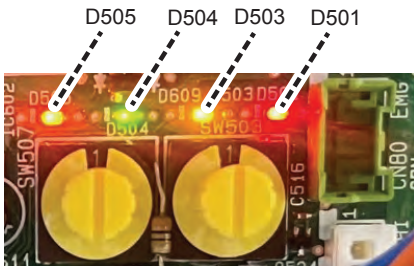

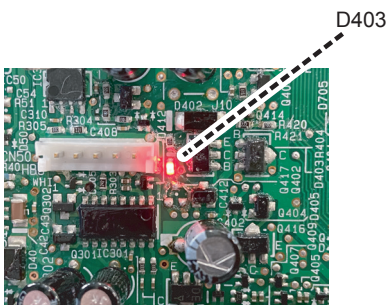

P.C. board LED		Meaning of lighting
D501	MCU power supply	Lights when the power is turned on
D503	Main bus communication	Flashes every 5 seconds. With central control: lighting and flashing every 5 seconds.
D504	Sub bus communication	Flashes every 5 seconds. Group: lighting and flashing every 5 seconds.
D505	Mod bus communication	When connected to Modbus, it lights up every 5 seconds.
D403	Sub bus power supply	Sub bus lights while power is being supplied.

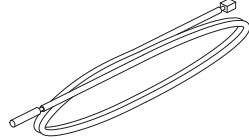
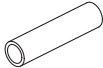

## 3. Accessories

### 3-1. Dx-coil controller 40VAM--C8FATEE, 40VAMR-C8FATEE

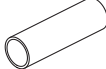
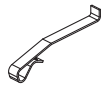
No.	Item	Q'ty	Shape
1	TA sensor (Length: 7.5 m, Connector color: Yellow)	1	
2	TC1 sensor (Length: 7.5 m, Connector color: Brown)	1	
3	TC2 sensor (Length: 7.5 m, Connector color: Black)	1	
4	TCJ sensor (Length: 7.5 m, Connector color: Red)	1	
5	TF sensor (Length: 7.5 m, Connector color: Green)	1	
6	Sensor holder (TC1) (O.D. 6.35 mm, Length: 26 mm)	1	
7	Sensor clip (TC1)	1	
8	Sensor holder (TC2, TCJ) (O.D. 8 mm, Length: 26 mm)	2	
9	Sensor clip (TC2, TCJ)	2	

There are no accessories for the sensor holders for the TA sensor and TF sensor.  
No. 6, 7, 8 and 9 are also included in the Dx-valve kit. Please use either one.

### 3-2. Dx-valve kit 40VA010V8-ATEE, 40VA020V8-ATEE

No.	Item	Q'ty	Shape
1	Sensor holder (TC1) (O.D. 6.35 mm, Length: 26 mm)	1	
2	Sensor clip (TC1)	1	
3	Sensor holder (TC2, TCJ) (O.D. 8 mm, Length: 26 mm)	2	
4	Sensor clip (TC2, TCJ)	2	
5	Heat insulation (O.D. 40 mm, Length: 210 mm)	2	
6	Cable tie (Length: 152 mm)	1	

There are no accessories for the sensor holders for the TA sensor and TF sensor.

# 4. Installation

## External dimensions and Installation space

Be sure to install the controller, valve kit in the indoor. Failure to do so may cause the frost formation, rust, or malfunction.

### 40VAM--C8FATEE, 40VAMR-C8FATEE

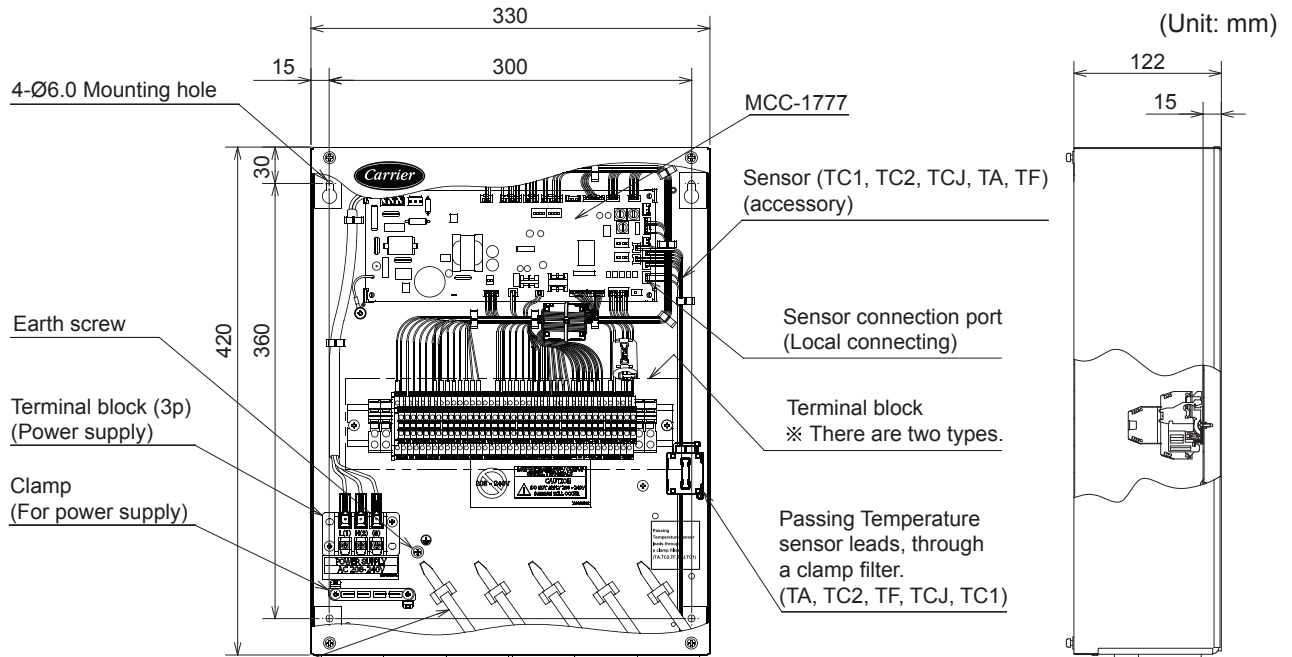

Clamp (5 piece)

Bushing (6 piece)

The bushing does not have a slit at the time of shipment. Please add a slit at the time of construction and let the wiring pass through.

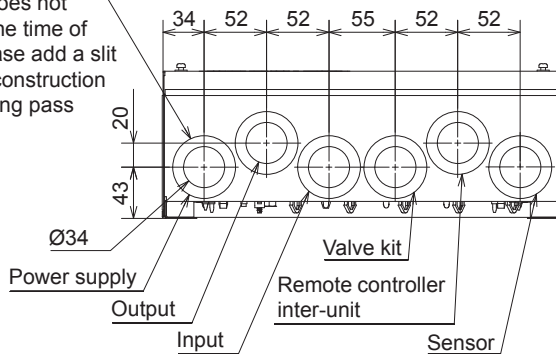

Note)

- This product is designed for the indoor installation.
- If the temperature sensor is short, use the Optional Sensor 40VA10-S8FATEE. (Temperature sensor with 10 m wiring length)

※ Terminal block type classification table.

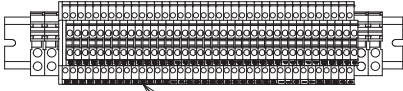
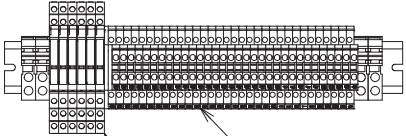
<p>40VAM--C8FATEE (Terminal block without relay)</p>	 <p>Terminal block (38P)</p>
<p>40VAMR-C8FATEE (Terminal block with relay)</p>	 <p>Terminal block (32P) Terminal block (6P with relay)</p>

• Installation space and maintenance space.

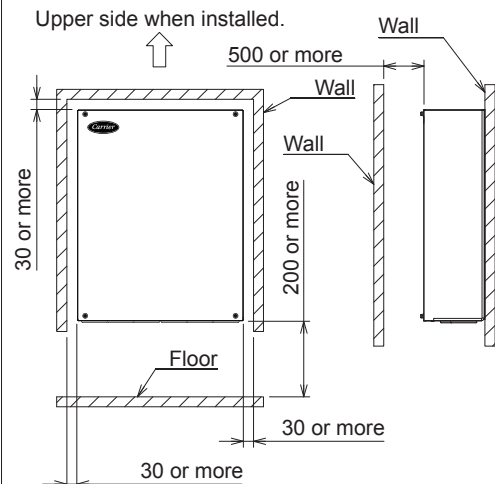



# 40VA010V8-ATEE, 40VA020V8-ATEE

(Unit: mm)

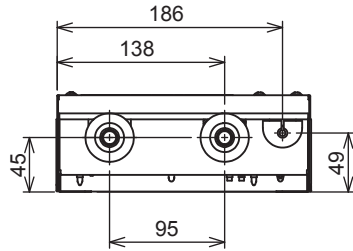
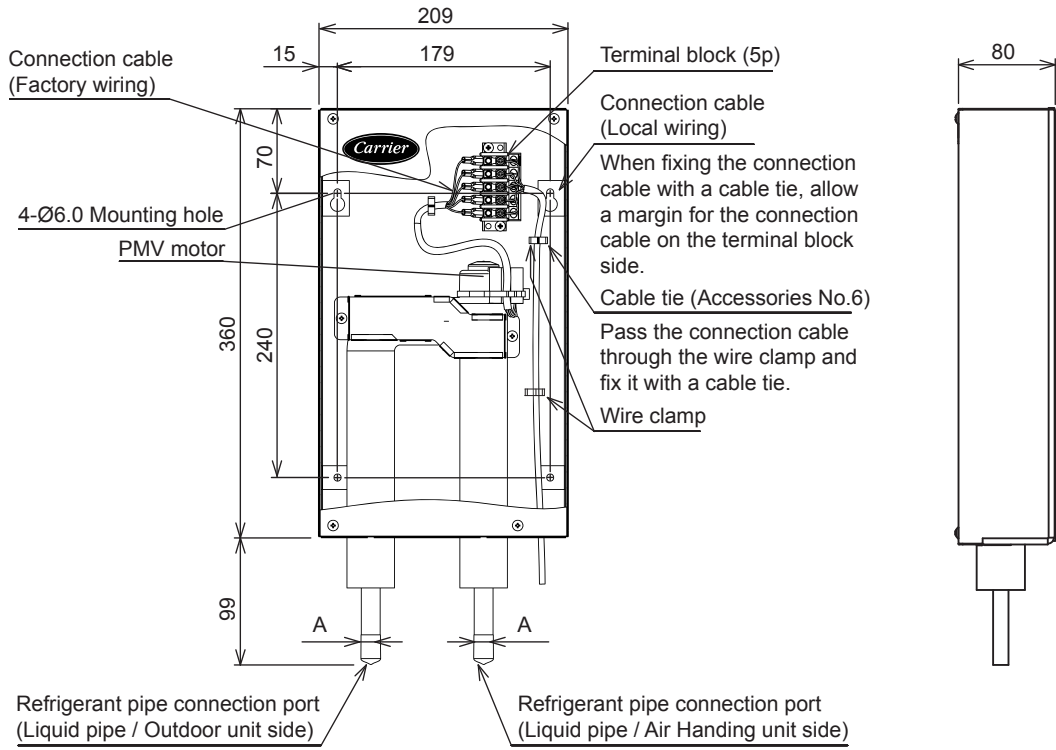

Note)  
This product is designed for the indoor installation.

Model	A (Pipe)
40VA010V8-ATEE	Ø12.7
40VA020V8-ATEE	Ø15.88

• Installation space and maintenance space.

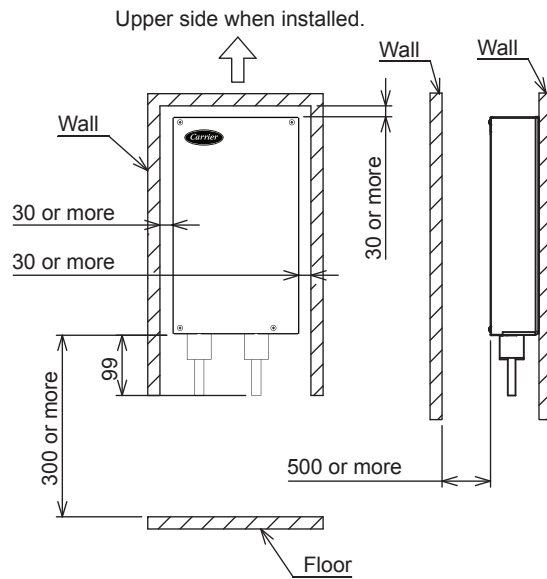



## ■ Installation Dx-valve kit (Refrigerant pipe)

By the refrigerant circuit diagram, braze the sensor holder of TC1, TC2, TCJ of the valve kit and the accessory. Refer to the below table for the pipe diameter and the pipe length to use.

Item		TA type	TF, DDC type
Main pipe equivalent length		Same as piping length restriction of outdoor unit	
Total piping length (real length)		200 m	120 m (100 m)
Furthest equivalent pipe length L (real length)		130 m (120 m)	100 m
Furthest equivalent pipe length from the 1st branch		40 m	-
Furthest equivalent pipe length between outdoor unit		Same as piping length restriction of outdoor unit	-
Max, real length of pipes connected to indoor units		20 m	-
Maximum equivalent between branching section		30 m	-
Max. Height Difference	Outdoor unit - Indoor unit (Upper outdoor unit) H1	40 m or the outdoor unit spec. Whichever is shorter of outdoor unit.	40 m
	Outdoor unit - Indoor unit (Lower outdoor unit) H1		
	Indoor unit - Indoor unit (Upper outdoor unit) H2		-
	Indoor unit - Indoor unit (Lower outdoor unit) H2		-

### Dx-valve kit and connection of the pipe

- Be sure to cool the strainer and PMV valve body using a wet cloth so that the body temperature does not exceed 120°C while brazing.
- For the connection pipe, it may vibrate during the defrosting operation. Carry out the installation work so that the connection pipe does not break after a long-term use.

### Sensor holders

- To ensure reliable operation, all Sensor holders must be fitted by brazing.
- Be careful of that the brazing material does not enter into the sensor holder when attaching the TC1, TC2 and TCJ sensor holder.

### TC1 sensor

- Install it in the collecting part of the gas header.

### TC2 sensor

- Install it in the between the liquid pipe distributor and the PMV.  
(TC2 sensor is attached to the refrigerant cycle of AHU.)

### TCJ sensor

- Install it in the pass where the temperature of the capillary tube is the lowest.
- Keep a distance of 50 mm ± 25 mm from the end plate.

### TA, TF sensor

- Install the TA, TF sensor where the better of air flow.
- The TA sensor must be located in the Return Air position, prior to mixing with any fresh air.
- Install the TF sensor in a place where the discharge air temperature is uniform.

If the TC1, TC2, or TCJ sensor are easy to be subjected to the surrounding thermal effect, cover them with the heat insulator material, and fix them with the fixing band.

If the lead wires of various sensors are left over, protect them from the effects of external force, heat, and water, and fix them with a fixing band. If the lead wires of various sensors do not reach, use the Optional Sensor 40VA010-S8FATEE (Temperature sensor with 10 m wiring length).

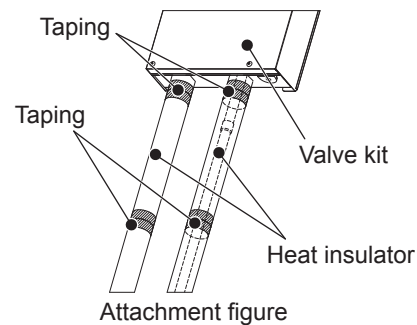
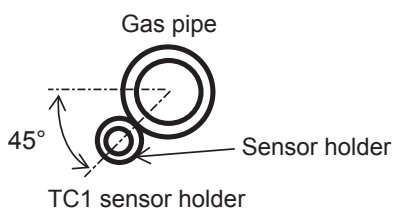

Braze the TC1 sensor on the location of the lower side 45° to detect the stable temperature.

After brazing the pipe, wrap the attached heat insulator and fix it with a tape.

## TC1, TC2 and TCJ sensor position on DX COIL

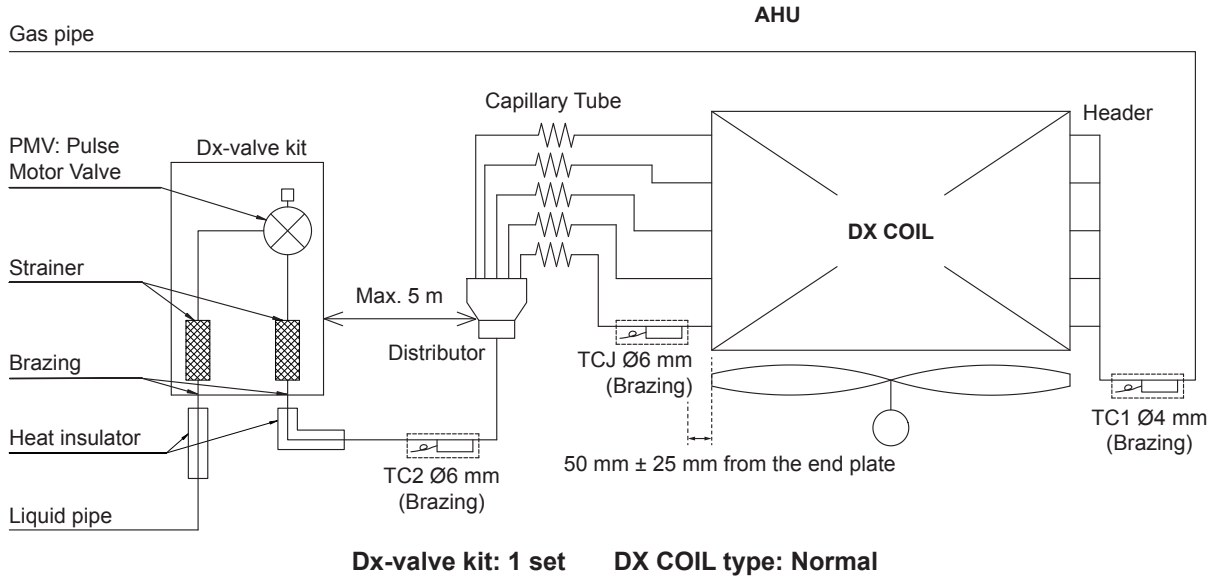

### Example TA / TF<sup>1</sup> sensor position

#### 1. Fresh Air Only

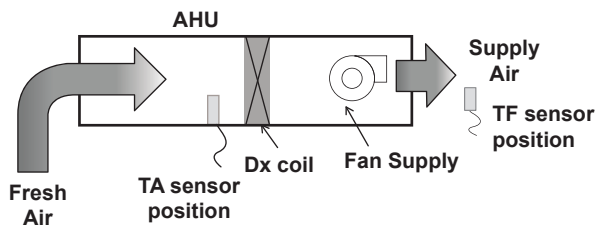

#### 2. Outdoor Air (Fresh Air) mixed with Return Air

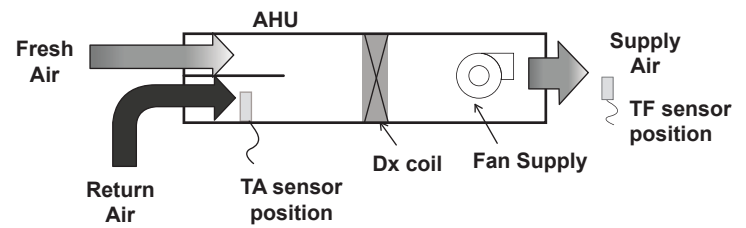

#### 3. Outdoor Air (Fresh Air) mixed with Return Air by Heat Recovery Exchanger

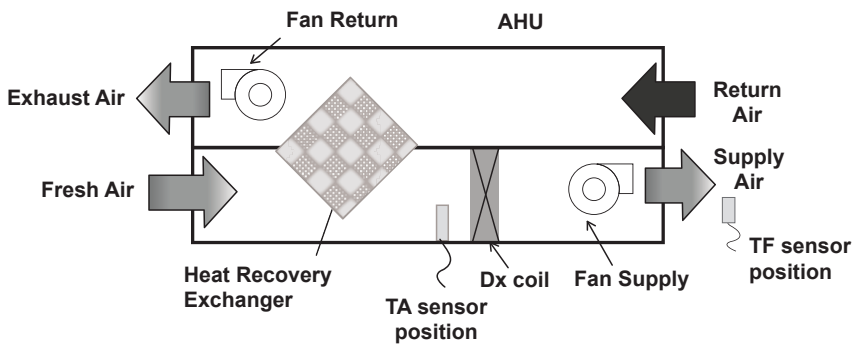

\*1: TF sensor can only be used with XCT8.

## Refrigerant circuit diagram

(1) Gas pipe

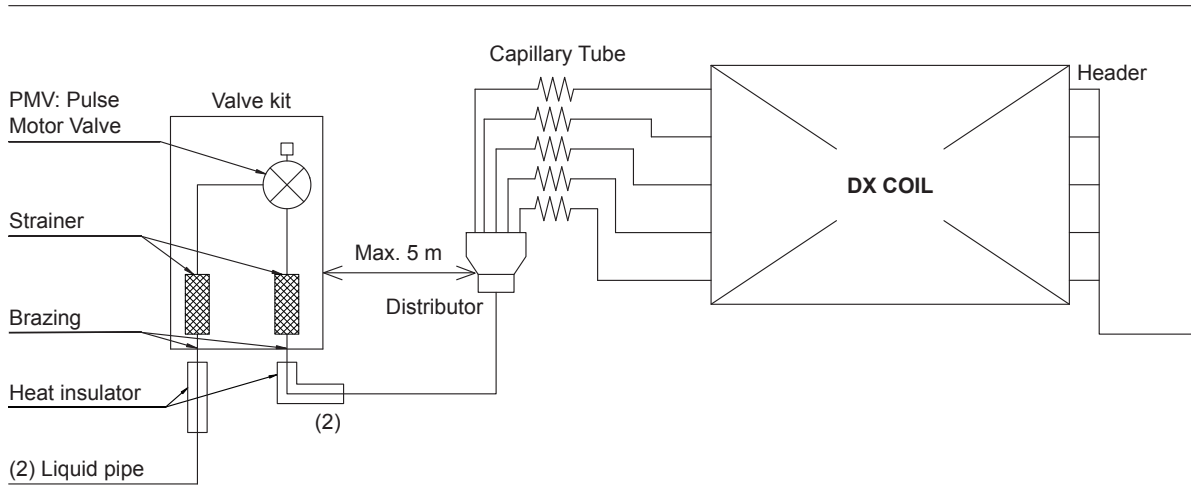

**Valve kit: 1 set**

**DX COIL type: Normal**

(1) Gas pipe

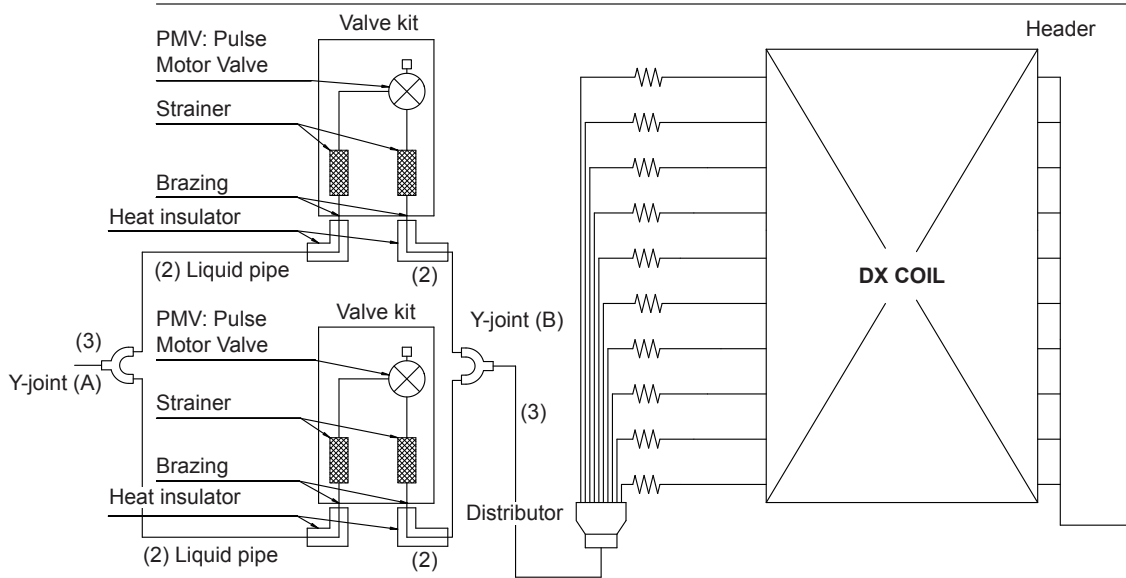

**Valve kit: 2 sets**

**DX COIL type: Normal**

(1) Gas pipe

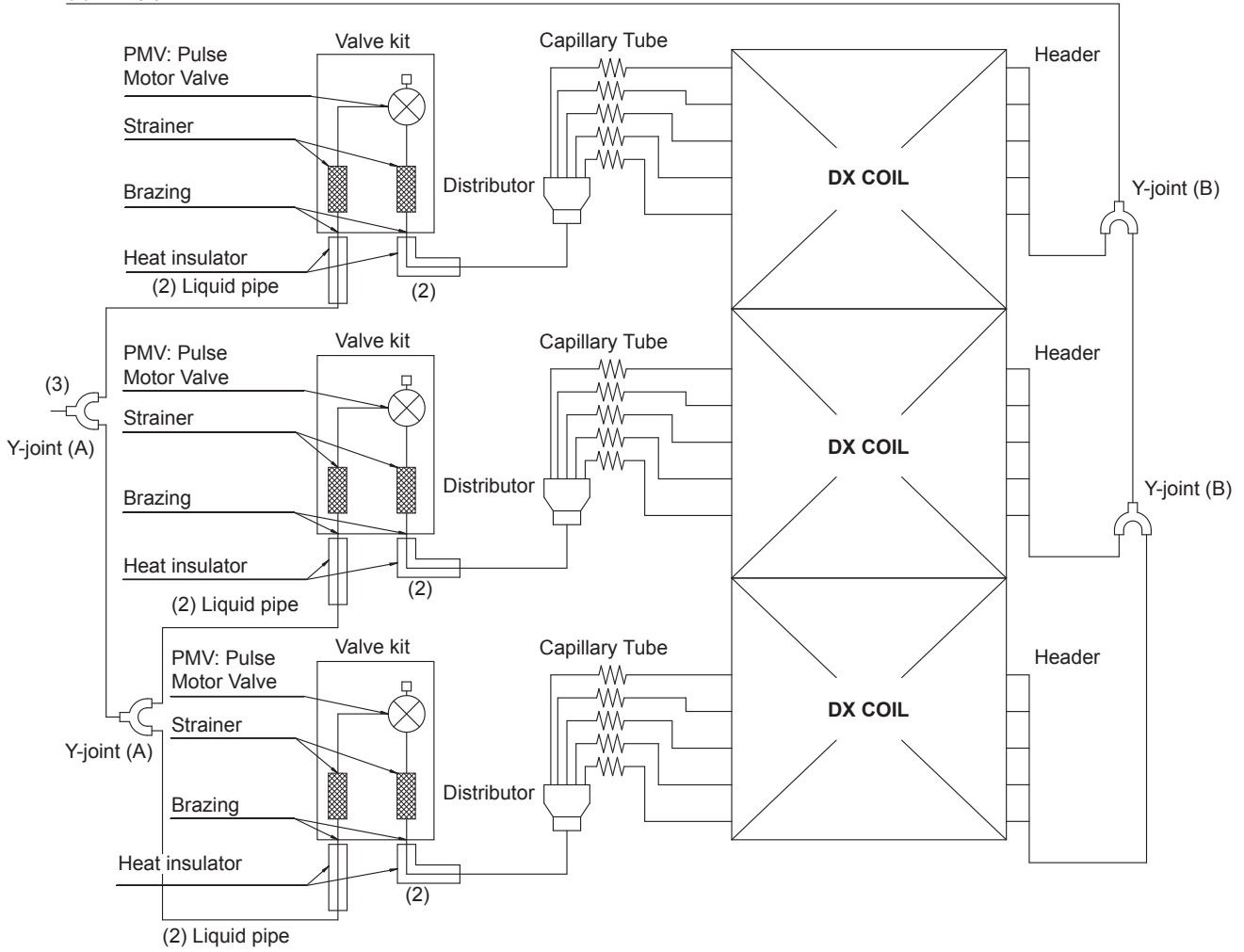

**Valve kit: 3 sets**

**DX COIL type: Interlaced, Split face**



**Piping size and Y-joint**

- Maximum real piping length between valve kit and Dx-coil is up to 5 m.

DX COIL type	Pipe diameter		
	(1) Gas pipe	(2) Liquid pipe	(3) Liquid pipe
HP	Outer diameter		
8	19.1	12.7	/
10	22.2		
12	28.6		
14 ~ 18		15.9	
20			
22		34.9	
24 ~ 26	19.1		
28 ~ 34		38.1	
36 ~ 42	22.2		
44 ~ 52			
54			
56 ~ 60			
62 ~ 74		44.5	
76 ~ 92			54
94 ~	25.4		

DX COIL type	Normal
HP	Y-joint (A, B)
24	RBM-BY205E
26 ~ 60	RBM-BY305E
61.2 or more	RBM-BY405E

(Unit: mm)

## ■ Installation Dx-coil controller (Electrical wiring, DN setting)

### WARNING

1. Using the specified wires, ensure to connect the wires, and fix wires securely so that the external tension to the wires do not affect the connecting part of the terminals. Incomplete connection or fixation may cause a fire, etc.
2. Be sure to connect earth wire (grounding work). Incomplete grounding cause an electric shock. Do not connect ground wires to gas pipes, water pipes, lightning rods or ground wires for telephone wires.
3. Appliance shall be installed in accordance with national wiring regulations. Capacity shortage of power circuit or incomplete installation may cause an electric shock or a fire.

### REQUIREMENT

- For power supply wiring, strictly conform to the Local Regulation for each country.
- For wiring of power supply of the outdoor units, follow the Installation Manual of each outdoor unit.
- Perform the electric wiring so that it does not come in to contact with the high-temperature part of the pipe. The coating may melt in an accident.
- After connecting wires to the terminal blocks, provide a trap and fix the wires with the cord clamp.
- Run the refrigerant piping and control wiring line in the same line.
- Do not turn on the power of the indoor unit until vacuuming of the refrigerant pipes completes.

### CAUTION

- If incorrect / incomplete wiring is carried out, it will cause an electrical fire or smoke.
- Be sure to install an earth leakage breaker that is not tripped by shock waves. If an earth leakage breaker is not installed, an electric shock may be caused.
- Be sure to use the cord clamps attached to the product.
- Do not damage or scratch the conductive core and inner insulator of power and inter-connecting wires when peeling them.
- Use the power cord and inter-connecting wire of specified thickness, type and protective devices required.
- Do not connect 208 - 240 V power to the terminal blocks (Uv (U1), Uv (U2), A, B, etc) for control wiring (otherwise the system will fail).

### Power supply wire and communication wires specifications

Power supply wire and communication wires are procured locally. For the power supply specifications, follow to the table below. If capacity is little, it is dangerous because overheat or burnout may be caused. For specifications of the power capacity of the outdoor unit and the power supply wires, refer to the Installation Manual attached to the outdoor unit. Cable size must be calculated for site condition and correct glands fitted. All cables should be in conduit or armored cables correctly glanced. This has to be done by the site installer.

### Dx-coil controller power supply

- For the power supply of the Dx-coil controller, prepare the exclusive power supply separated from that of the outdoor unit.
- Arrange the power supply, earth leakage breaker and main switch of the Dx-coil controller connected to the same outdoor unit so that they are commonly used.
- Power supply wire specification: Cable 3-Core, 2.5 mm<sup>2</sup>, in conformity with Design 60245 IEC 57.

### ▼ Power supply

Power supply	220 - 240 V ~, 50 Hz 208 - 230 V ~, 60 Hz	
Power supply switch / Earth leakage breaker or power supply wirings / fuse rating for Dx-coil controllers should be selected by the accumulated total current values of the Dx-coil controllers.		
Power supply wiring (power supply and earth)	Below 50 m	2.5 mm <sup>2</sup>
Current consumption	0.3 A	

### Control wiring, Central controller wiring

- 2-core with polarity wires are used for the Control wiring between indoor and outdoor unit and Central controller wiring.
- To prevent noise trouble, use 2-core shield wire.

**Communication line (Uv(U1), Uv(U2))**

Uv: Control wiring between Dx-coil controller and outdoor unit

Wiring	2-core, non-polarity
Type	Shield wire
Size / Length	1.0 mm <sup>2</sup> to 1.5 mm <sup>2</sup> / Up to 1000 m

**Remote controller wiring (A, B)**

Wiring	2-core, non-polarity
Type	Shield wire
Size	0.5 mm <sup>2</sup> to 2.0 mm <sup>2</sup>
Length	<ul style="list-style-type: none"> <li>Up to 500 m</li> <li>Up to 400 m (in case of two remote controller in group control)</li> <li>Up to 200 m (total length of communication line between indoor units)</li> </ul>

**Terminal information**0.5 mm<sup>2</sup> to 1.0 mm<sup>2</sup> - AWG 24 to AWG 18

Function	Terminal	Max. Cable Length (m)	Cable Specification
Analogue Input (4 - 20 mA)	AI1, 2 / *AI1, 2	100	Non shield wire: 0.5 - 1.0 mm <sup>2</sup>
Analogue Input (0 - 10 V)	AI3, 4 / *AI3, 4	200	Shield wire: 0.5 - 1.0 mm <sup>2</sup>
Analogue Output (0 - 10 V)	AO1, 2 / *AO1, 2	200	Shield wire: 0.5 - 1.0 mm <sup>2</sup>
Digital Input	DI1 - 6 / *DI1 - 6	100	Non shield wire: 0.5 - 1.0 mm <sup>2</sup>
Digital Output	DO1 - E / *DO1 - E	500	Non shield wire: 0.5 - 1.0 mm <sup>2</sup>

Use the following wiring materials to connect the communication cables and power cables. (locally procured)

Line	Description	
For RS-485	Type	2-core shielded wires
	Wire size	1.25 mm <sup>2</sup> , 500 m max.
	Length	(total length)

** CAUTION**

The remote controller wire, communication line and AC 208 - 240 V wires cannot be parallel to contact each other and cannot be stored in the same conduits. If doing so, a trouble may be caused on the control system due to noise, etc.

# Wiring diagram

## 40VAM--C8FATEE (Terminal block without relay)

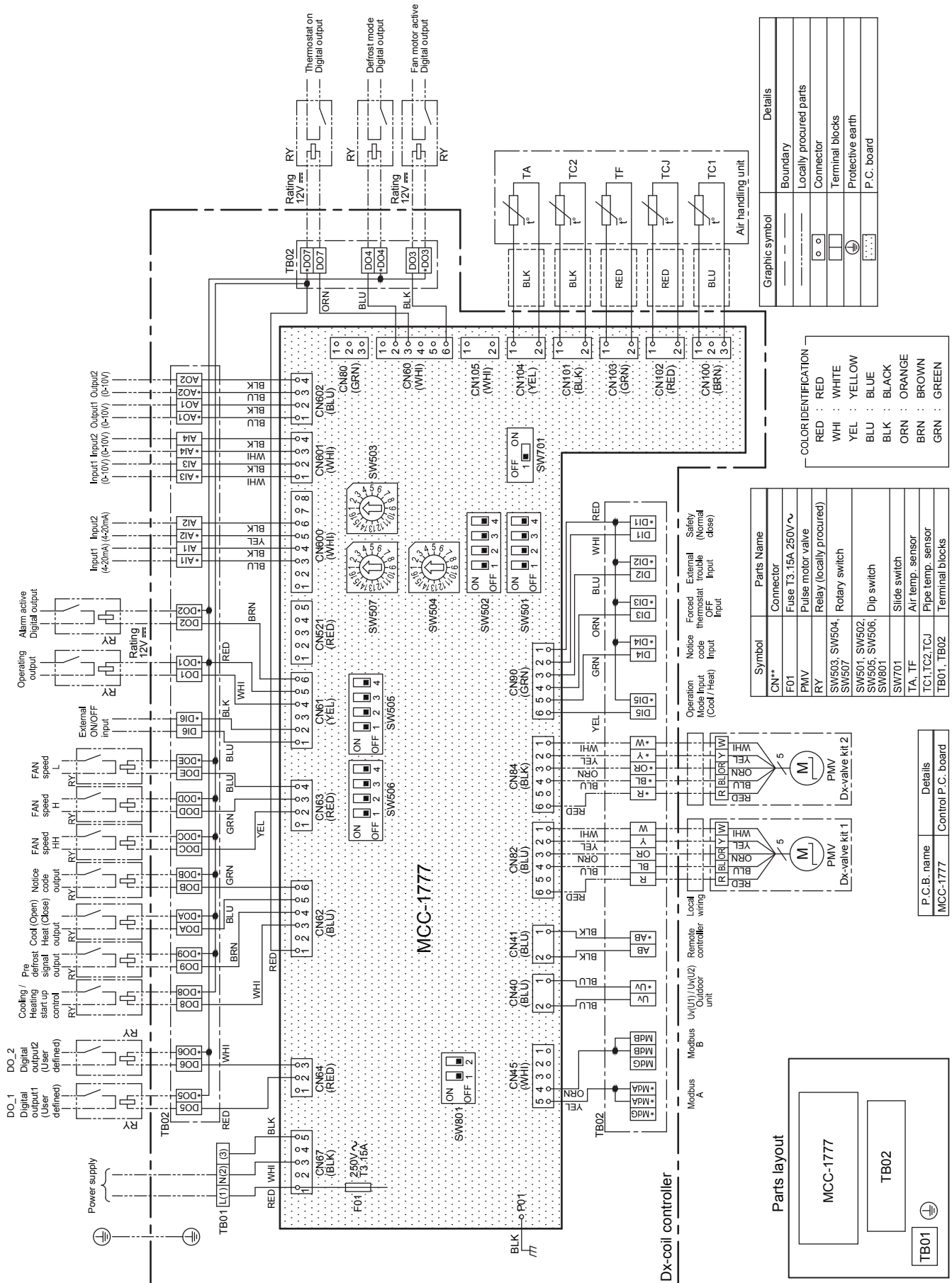

Graphic symbol	Details
-----	Boundary
-----	Locally procured parts
○ ○	Connector
□ □	Terminal blocks
⏚	Protective earth
⋮	P.C. board

COLOR IDENTIFICATION	
RED	: RED
WHI	: WHITE
YEL	: YELLOW
BLU	: BLUE
BLK	: BLACK
ORN	: ORANGE
BRN	: BROWN
GRN	: GREEN

Symbol	Parts Name
CN**	Connector
F01	Fuse T3.15A 250V~
PMV	Pulse motor valve
RY	Relay (locally procured)
SW503, SW504,	Rotary switch
SW507	Dip switch
SW501, SW502,	Slide switch
SW505, SW506,	Air temp. sensor
SW801	Pipe temp. sensor
TA, TF	Terminal blocks
TC1, TC2, TCJ	
TB01, TB02	

Symbol	Parts Name
○	Terminal block
□	Terminal block
⏚	Protective earth
⋮	P.C. board

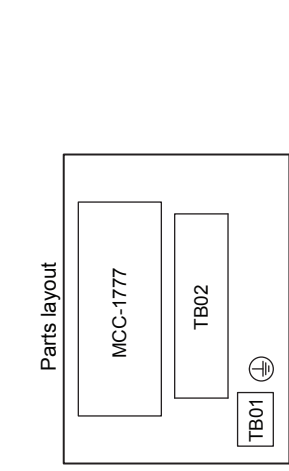



# 40VAMR-C8FATEE (Terminal block with relay)

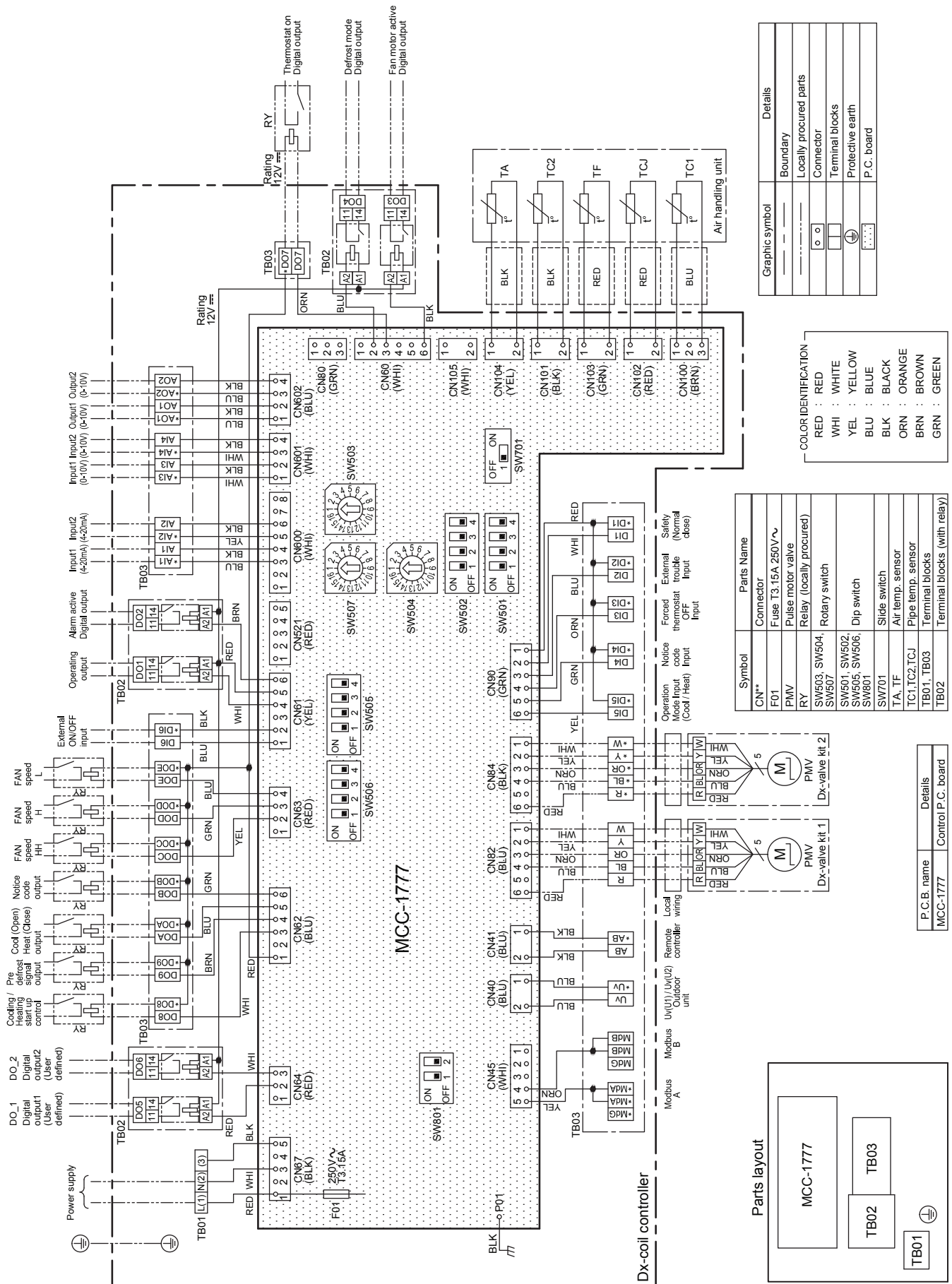

Graphic symbol	Details
---	Boundary
---	Locally procured parts
□	Connector
□	Terminal blocks
⊕	Protective earth
⋮	P.C. board

COLOR IDENTIFICATION

RED	: RED
WHI	: WHITE
YEL	: YELLOW
BLU	: BLUE
BLK	: BLACK
ORN	: ORANGE
BRN	: BROWN
GRN	: GREEN

Symbol	Parts Name
CN*	Connector
F01	Fuse T3.15A 250V~
PMV	Pulse motor valve
RY	Relay (locally procured)
SW503, SW504, SW507	Rotary switch
SW501, SW502, SW505, SW506, SW507	Dip switch
SW701	Slide switch
TA, TF	Air temp. sensor
TC1, TC2, TCJ	Pipe temp. sensor
TB01, TB03	Terminal blocks
TB02	Terminal blocks (with relay)

P.C.B. name	Details
MCC-1777	Control P.C. board

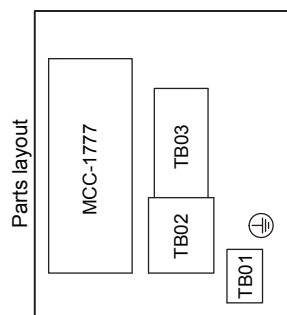





## ■ Interface P.C. board function setting exchange table

When operating the SW, turn off the power before setting.

SW	Bit	Function Name	OFF (Default)	ON	Detail																
SW501	1	No function	-	-	-																
	2	TA / TF type switching	TA type	TF type	The default is TA type. For TF type, turn on Bit2. If Bit3 is ON, the Bit2 setting is invalid.																
	3	DDC type switching	No function	DDC type	For DDC type, turn on Bit3.																
	4	DDC capacity control	Stepped	Linear	Change the capacity control method at 0 - 10 V. Refer to the functions of AI3.																
SW502	1	No function	-	-	-																
	2																				
	3																				
	4	Forced capacity control	None	Controlled	Refer to the functions of DI2 / *DI2 ~ *DI4 / DI4.																
SW503	-	Output signal selection	-	-	Refer to the functions of DO5 / *DO5 and DO6 / *DO6.																
SW504	-	(RSW)	-	-																	
SW505	1	DI1 input inversion	Close	Open	Refer to the functions of DI1.																
	2	No function	-	-	-																
	3																				
	4																				
SW506	1	Modbus baud rate	Refer to right table	-	-	<table border="1"> <thead> <tr> <th>Bit1</th> <th>Bit2</th> <th>Baud rate</th> </tr> </thead> <tbody> <tr> <td>OFF</td> <td>OFF</td> <td>9600</td> </tr> <tr> <td>ON</td> <td>OFF</td> <td>19200</td> </tr> <tr> <td>OFF</td> <td>ON</td> <td>38400</td> </tr> <tr> <td>ON</td> <td>ON</td> <td>57600</td> </tr> </tbody> </table>	Bit1	Bit2	Baud rate	OFF	OFF	9600	ON	OFF	19200	OFF	ON	38400	ON	ON	57600
	Bit1					Bit2	Baud rate														
	OFF					OFF	9600														
	ON					OFF	19200														
	OFF	ON	38400																		
ON	ON	57600																			
2																					
3	No function	-	-	-																	
4	No function	-	-	-																	
SW507	1	Modbus address setting (RSW)	-	-	Refer to “Modbus setting method” in this Installation Manual.																
SW701	1	Voltage / non-voltage switching SW	Voltage	Non-voltage	Refer to the functions of DI1 / *DI1.																
SW801	1	RS-485 terminating resistance setting	Open	120 ohm	Refer to “Modbus setting method” in this Installation Manual.																
	2	No function	-	-	-																

## ■ The specifications of Terminal DO1 to DO6

The specifications of Terminal DO1 to DO6 are as follows.

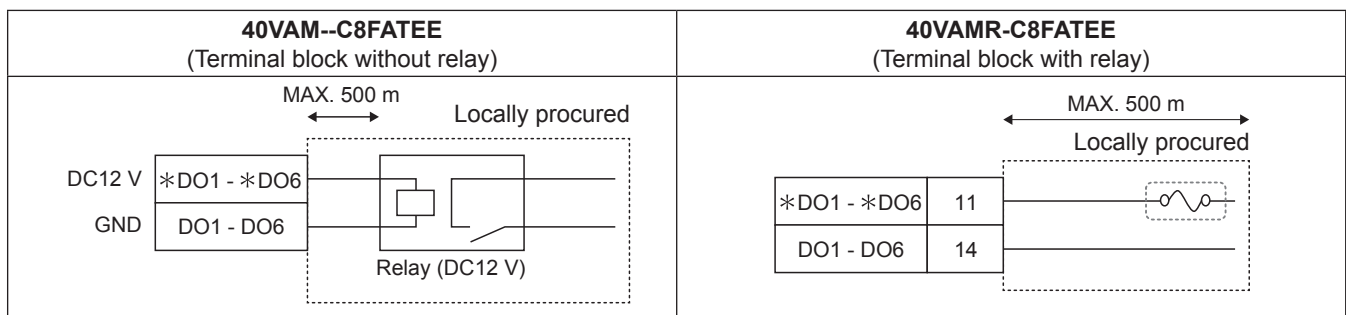

- Use the contact side of the relay terminal used in 40VAMR-C8FATEE according to the specifications shown in the table below.

Relay model name	Contact rating	Load conditions
G2RV-SR700-12DC	250 V max / 3 A max (Minimum Current: 10 mA more)	Resistive load

## ■ Function of each terminal blocks

### Terminal DO1 / \*DO1: Operating Output (DC12 V)

- The output is displayed when the system starts operation (output when the thermostat is on / off).

### Terminal DO2 / \*DO2: Alarm Active Digital Output (DC12 V)

- During Alarm operation, Alarm Active Digital Output is active.

### Terminal DO3 / \*DO3: Fan Motor Active Digital Output (DC12 V)

- A fan control signal is output. It is usually the ON output at the time of operating, but it is the OFF output in defrosting.

### Terminal DO4 / \*DO4: Defrost Mode Digital Output (DC12 V)

- During Defrost operation, Defrost Mode Output is active.

### Terminal DO5 / \*DO5: Digital Output 1 (DC12 V)

### DO6 / \*DO6: Digital Output 2 (DC12 V)

- Output function selected using rotary switches SW503 (DO5 / \*DO5) & SW504 (DO6 / \*DO6).

SW503, 504 Position	Output Function
1	Outdoor unit(s) operation level is lower than capacity command
2	Outdoor unit(s) operation level is higher than capacity command
3	Cooling oil recovery / Heating refrigerant recovery control
4	Cooling operation output
5	Heating operation output
6	The suction air temperature (TA) is in the thermostat OFF range (only TF type)
7 - 15	Do not use
16	Under restriction of compressor speed due to heat sink overheating in outdoor unit (s)

Set with the SW503 or SW504 switch on the control P.C. board MCC-1777.

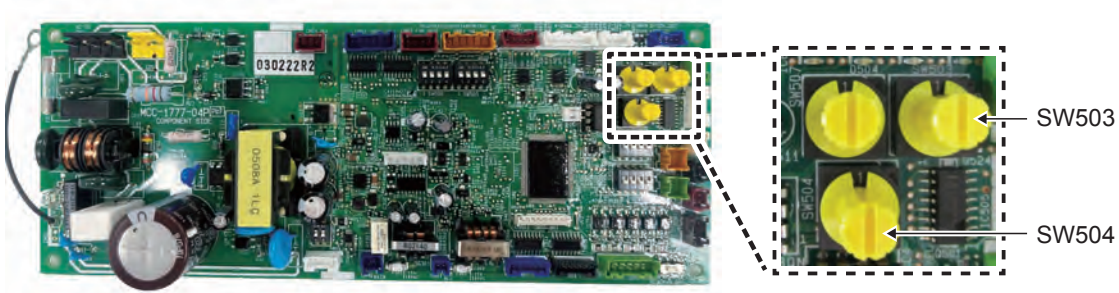

**Terminal DO7 / \*DO7: Thermostat on Digital output (DC12 V)**

- When the thermostat of Dx-coil is ON, a signal comes out.

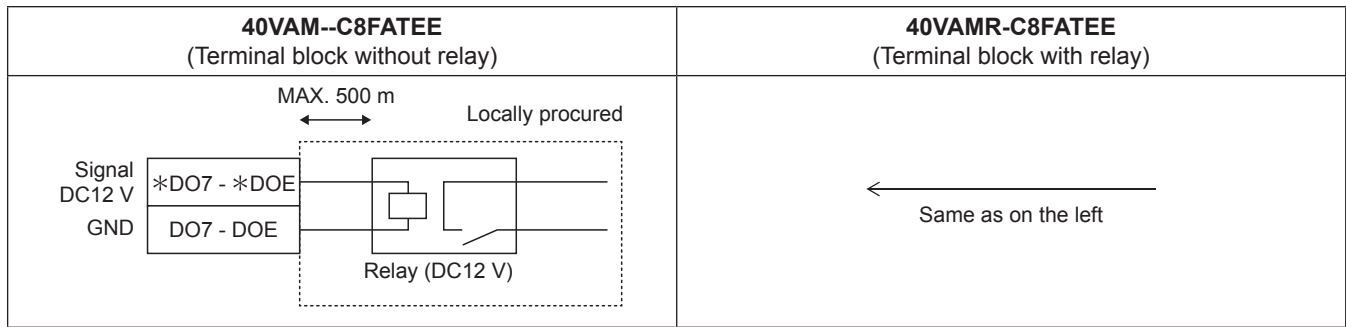

**Terminal DO8 / \*DO8: Cooling / heating start up control signal output**

- Outputs the start control signal for cooling and heating operation.

**Terminal DO9 / \*DO9: Pre defrost signal**

- Output just before defrosting (at least 5 minutes before).

**Terminal DOA / \*DOA: Cool open heat close output**

- Heating mode is close, Cooling mode is open.

**Terminal DOB / \*DOB: Notice code output**

- Issued when Notice code is output. For details, see the outdoor unit Service Manual.

**Terminal DOC / \*DOC, DOD / \*DOD, DOE / \*DOE: FAN speed output**

- If select the fan output from interface, use this output. For TA and TF types, the output changes by changing the fan speed from the remote controller.

DOC = High / DOD = Mid. / DOE = Low

**Terminal N1 / \*N1, N2 / \*N2: Nothing**

**The specifications of Terminal DI1 to DI5 are as follows.**

- You can switch between voltage and non-voltage with SW701.

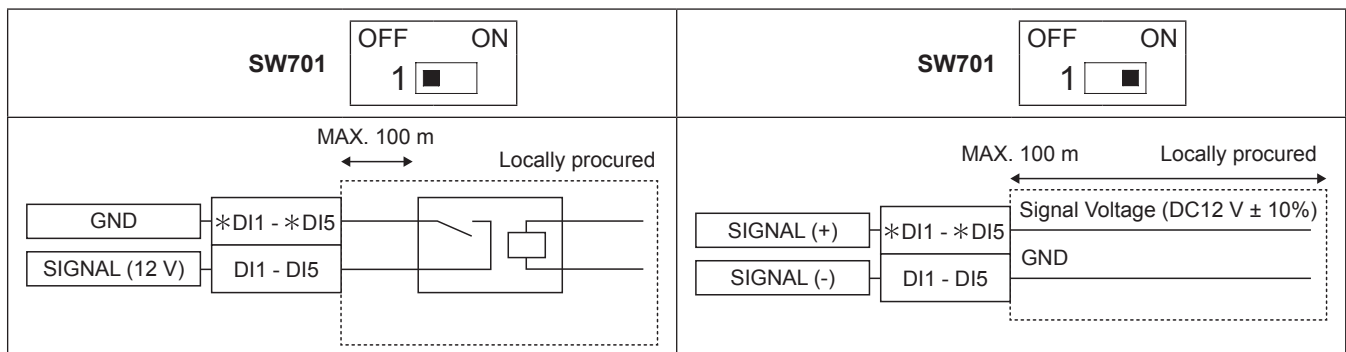
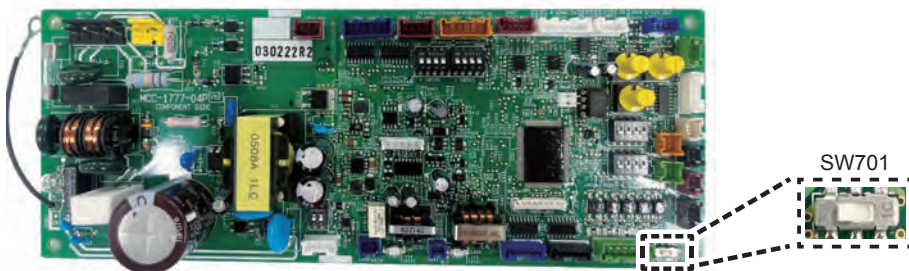

**Terminal DI1 / \*DI1: Safety contact (Normal close)**

MODE 1 (Normally close, DC12 V) \*When Bit1 of SW505 is OFF

- If this contact is open for more than 1 minute, the check code P10 is generated and the Dx-coil controller switches off automatically.

MODE 2 (Normally open, DC12 V) \*When Bit1 of SW505 is ON

- If this contact is short for more than 1 minute, the check code P10 is generated and the Dx-coil controller switches off automatically.

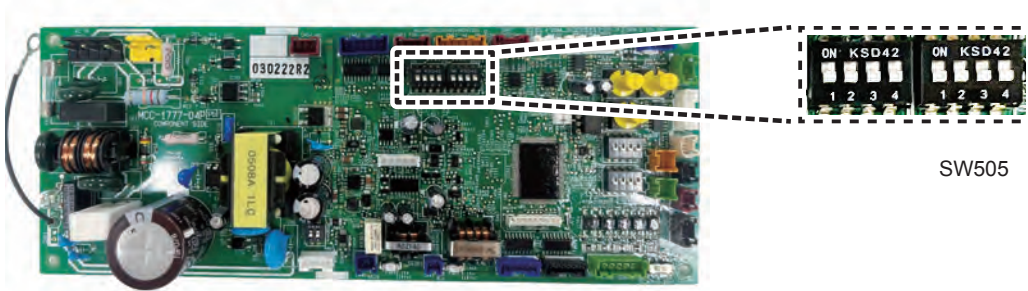

SW505

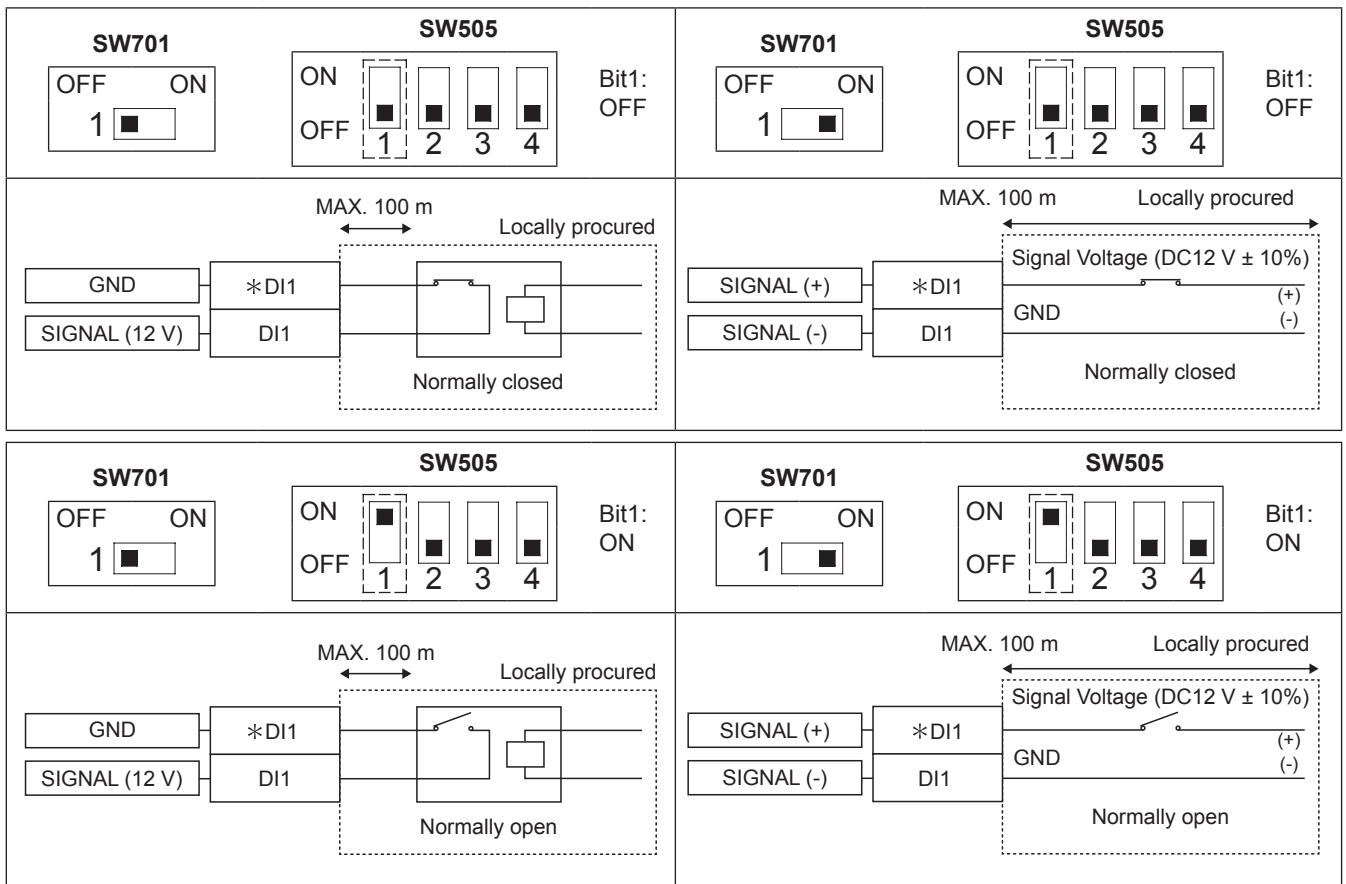

SW701	SW505	Function
OFF	OFF	The coil drive voltage is input to the relay arranged locally for DI1, and judge that the close is positive. (Default) Relay: Local arrangement
	ON	The coil drive voltage is not input to the relay arranged locally for DI1, and judge that the open is positive. Relay: Local arrangement
ON	OFF	For *DI1, short-circuit the (+) signal voltage and DI1 (-) GND with a SW or harness, and judge that the close is positive. Relay: Not required * The signal voltage is DC12 V ± 10%, and it is necessary to add a SW element to the signal line.
	ON	For *DI1, open the (+) signal voltage and DI1 (-) GND, and judge that the open is positive. Relay: Not required * The signal voltage is DC12 V ± 10%, and it is necessary to add a SW element to the signal line.

**Terminal DI2 / \*DI2: External trouble Input**

- An AHU fan operation monitor (Field supply), could be attached at this dry contact terminal (For example, the abnormality of the fan motor). A closed contact generates the check code L30.

**Terminal DI3 / \*DI3: Forced thermostat OFF Input**

- When signal input, AHU is in “thermostat-off” status forcibly.

**Terminal DI4 / \*DI4: Notice code Input**

- If there is input, a spanner mark will be displayed on the remote controller. The system will not stop. Check “DN settings” for the setting method.

**Terminal DI5 / \*DI5: Operation Mode Input (Cool / Heat)**

- Cool / Heat mode selection over a dry contact.  
If the contact is short-circuited, system changes to heat mode. If the contact is open, system changes to cool mode.
- Only cool mode and heat mode are available.

Function	Terminal	Function	SHORT
Mode Input Cool / Heat	DI5 / *DI5	COOL mode active	HEAT mode active

When Bit4 of SW502 is turned on in DDC type, capacity demand can be achieved by short-circuiting Terminals DI2 to DI4.

Short - circuit	Cooling step	Heating step
*DI2 - DI2	2	3
*DI3 - DI3	5	9
*DI4 - DI4	11	13

\* If all are short-circuited, the DI3 function has priority.

When SW701 is ON (no voltage), apply a voltage of DC12 V ± 10% and wiring as follows.

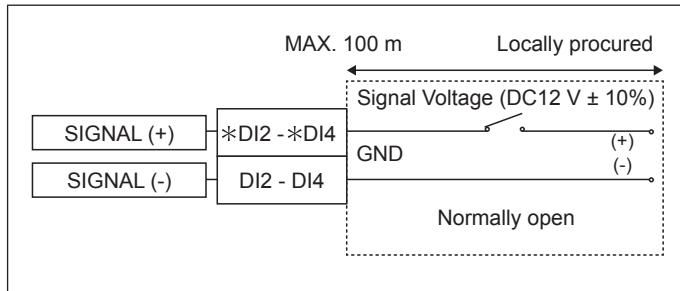

**Terminal DI6 / \*DI6: External ON/OFF Input**

- When using with DDC, it starts by turning on this terminal.

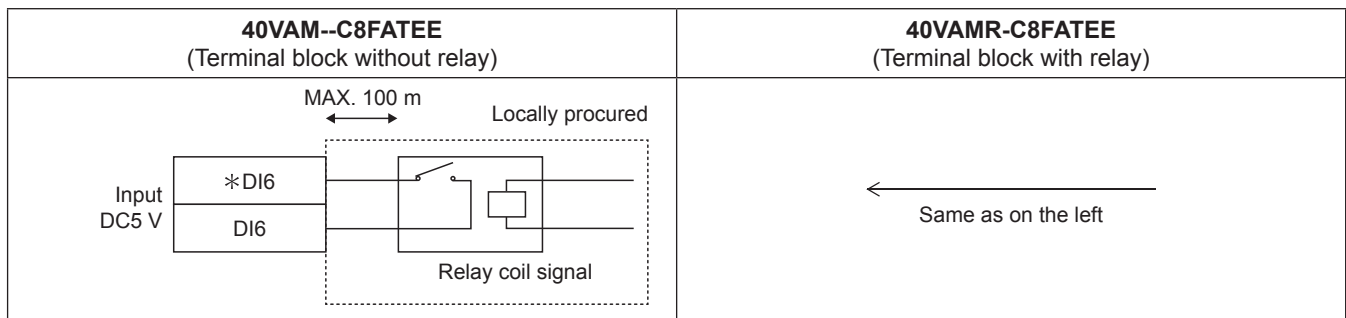



### The position of J01 (MCC-1777)

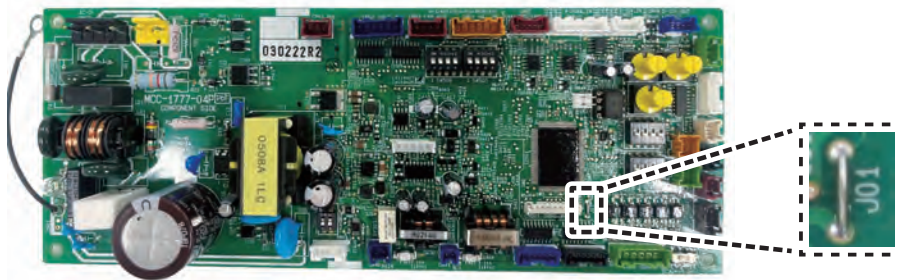

J01	Action
Connect	Pulse input (At factory setting) Pulse width 200 to 300 ms Pulse interval 200 to 300 ms or more.
Cut	Static input

#### Terminal AI1 / \*AI1: 4 - 20 mA FAN interlocking control by external input

- FAN mode is switched by external 4 - 20 mA input.
  - Both FAN control with 4 - 20 mA input and FAN mode change with remote controller are valid, but boost priority is given.
  - The FAN priority control is switched by the DN setting of [4A0].
  - 0000: Default (no change in FAN mode by 4 - 20 mA input)
  - 0001: FAN control by 4 - 20 mA input, but priority is given to FAN control from the outdoor unit
  - 0002: FAN control 4 - 20 mA input with priority
  - The FAN mode switching threshold value for 4 - 20 mA input can be changed in the DN setting (See the table as below).
- \* Terminal AI2 / \*AI2 cannot be used.  
 \* The change in FAN speed with 4 - 20 mA input is also reflected in the 0 - 10 V output of AO1 / \*AO1.

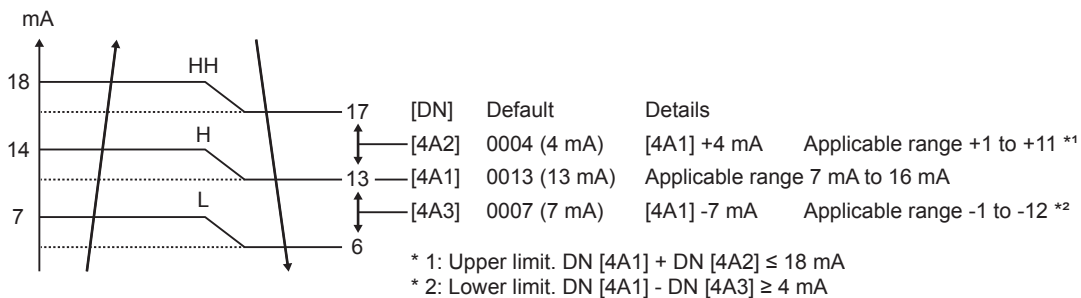

40VAM--C8FATEE (Terminal block without relay)	40VAMR-C8FATEE (Terminal block with relay)
MAX. 100 m      Locally procured (Input 4 - 20 mA) *AI1      4 - 20 mA Signal (+) AI1      GND (-)	← Same as on the left



**Terminal AI3 / \*AI3: Analogue Input Capacity Control**

- Be sure not input more than DC10 V in analogue input terminal.
- To ease the integration of the DX COIL with the DDC the capacity control is able to operate with a STEPPED or LINEAR function from the analogue input.
- To select either a STEPPED (default) or LINEAR response, from the analogue input, use SW501 Bit4.
- Terminal AI4 / \*AI4 cannot be used.

SW501 Bit4	Terminal
OFF	STEP response to analogue input
ON	LINEAR response to analogue input

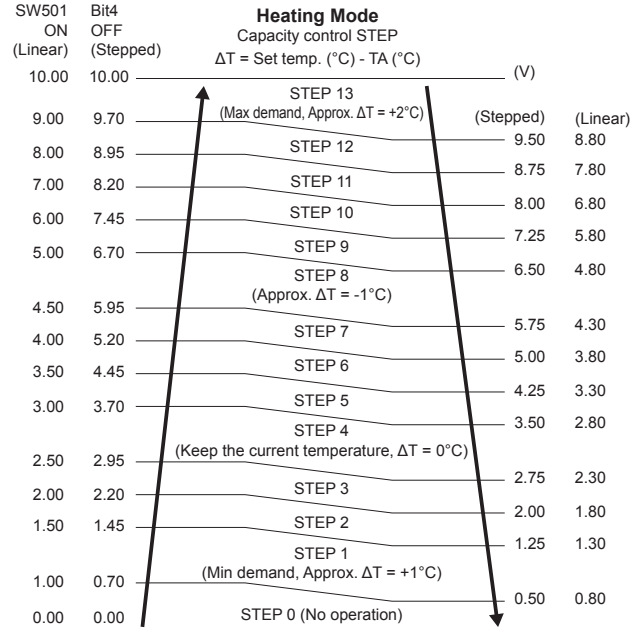
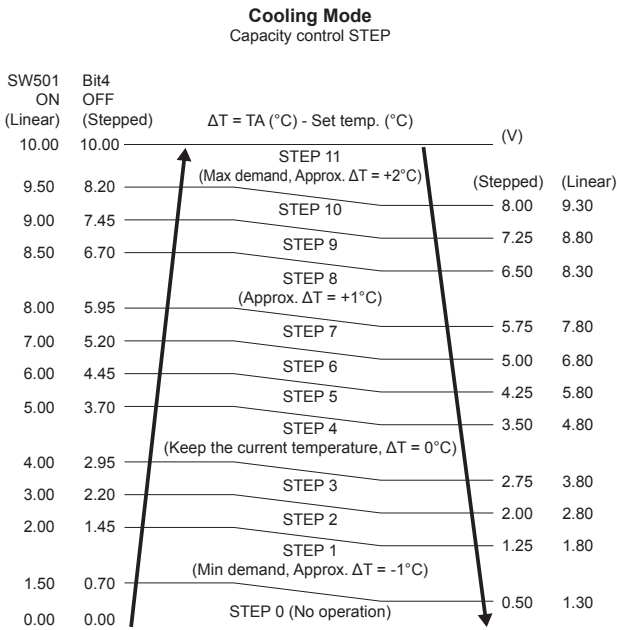
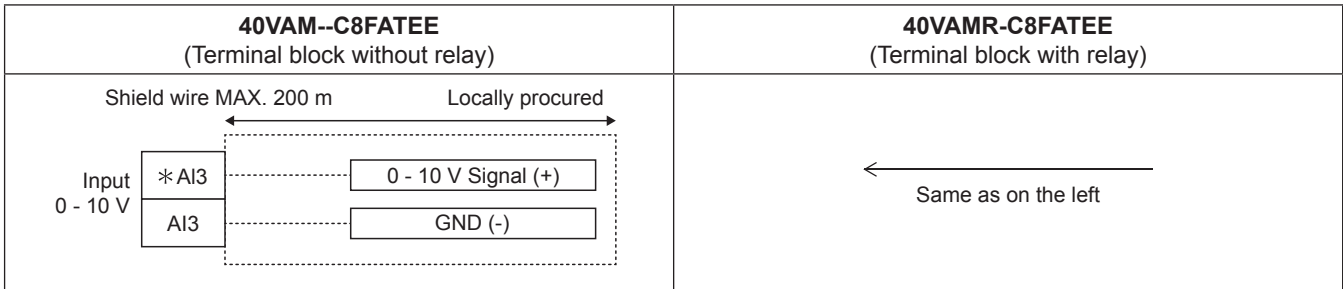

- For TA and TF type, the set temperature can be changed according to the 0 - 10 V input of AI3.
- In the set temperature with the remote controller and this control, the post-setting is prioritized.
- The set temperature can be changed only for cooling and heating operations.
- To use this control, set DN [4A9] = 1.

▼ TA type

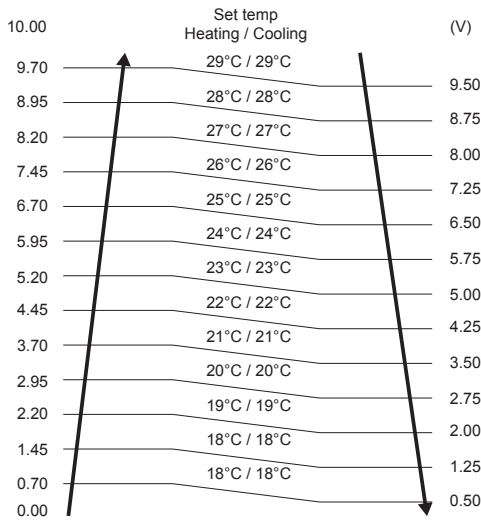

▼ TF type

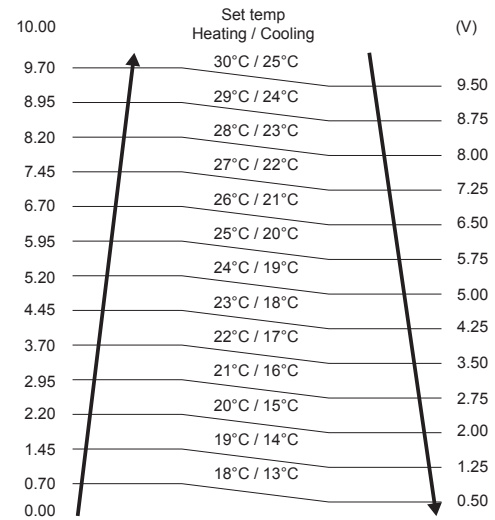

**Terminal AO1 / \*AO1: FAN speed 0 - 10 V output**

- Each FAN speed is output at 0 - 10 V.
- The ripple voltage of 0 - 10 V is less than  $\pm 30$  mV of the set voltage. Connect equipment that is not affected by this ripple voltage.
- The output voltage can be changed by DN setting [4A4] to [4A6].
- \* Terminal AO2 / \*AO2 cannot be used.

FAN speed	Output (Def)	Initial (Def)	Applicable range
HH	9 V	4A4 (0009)	8 V (0008) - 10 V (0010)
H	6 V	4A5 (0006)	4 V (0004) - 7 V (0007)
L	2 V	4A6 (0002)	1 V (0001) - 3 V (0003)
STOP	0 V	-	-

**CAUTION**

The impedance of the device that receives the 0 - 10 V output signal shall be 10 k $\Omega$  or more.

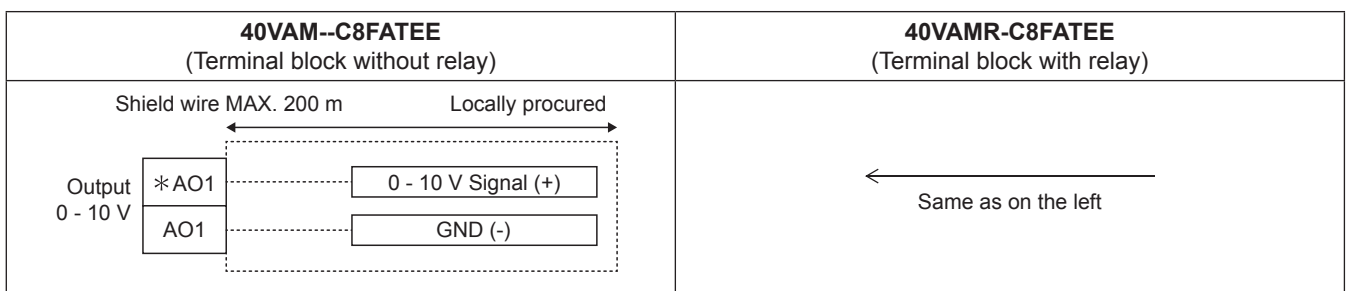

**Temperature Set Point**

- When a wired remote controller is fitted the temperature set point can be changed, however this has no impact on the demand, which is controlled by the 0 - 10 V Analog Input.

**Terminal: R / BL / OR / Y / W**

Dx-valve kit 1, Dx-valve kit 2 : Connect the cable from the PMV.  
Match the color of the wiring of the PMV side and the controller side.

Color identification	
W:	White
Y:	Yellow
OR:	Orange
BL:	Blue
R:	Red

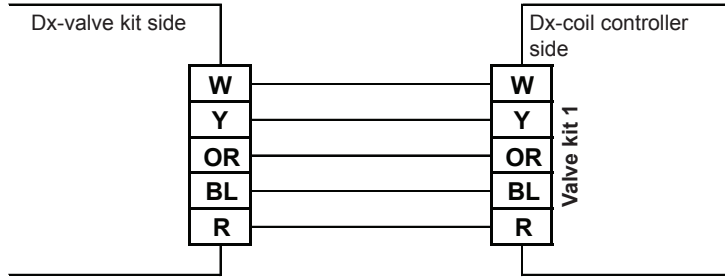

40VA010V8-ATEE	8, 10, 12 HP
40VA020V8-ATEE	14, 16, 18, 20 HP

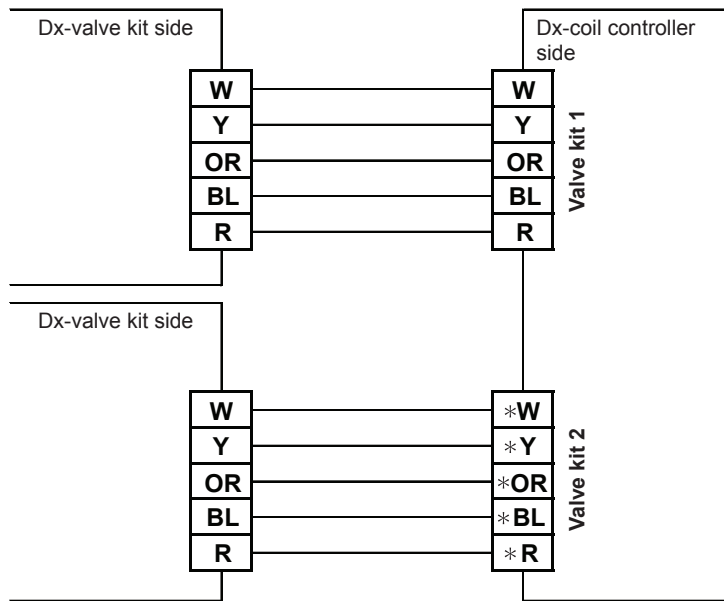

40VA010V8-ATEE	24 HP (12 HP × 2)
40VA020V8-ATEE	28 HP (14 HP × 2), 32 HP (16 HP × 2) 36 HP (18 HP × 2), 40 HP (20 HP × 2)

- For the PMV, sensor wiring, do not bundle it with the motor wiring. The wrong operation may result in.
- The PMV cable cannot be extended, it is supplied at the maximum permissible length of 5 m.

## ■ Modbus setting method

Modbus communication is available on this model. Follow the procedure below to set.

### 1. Wiring method

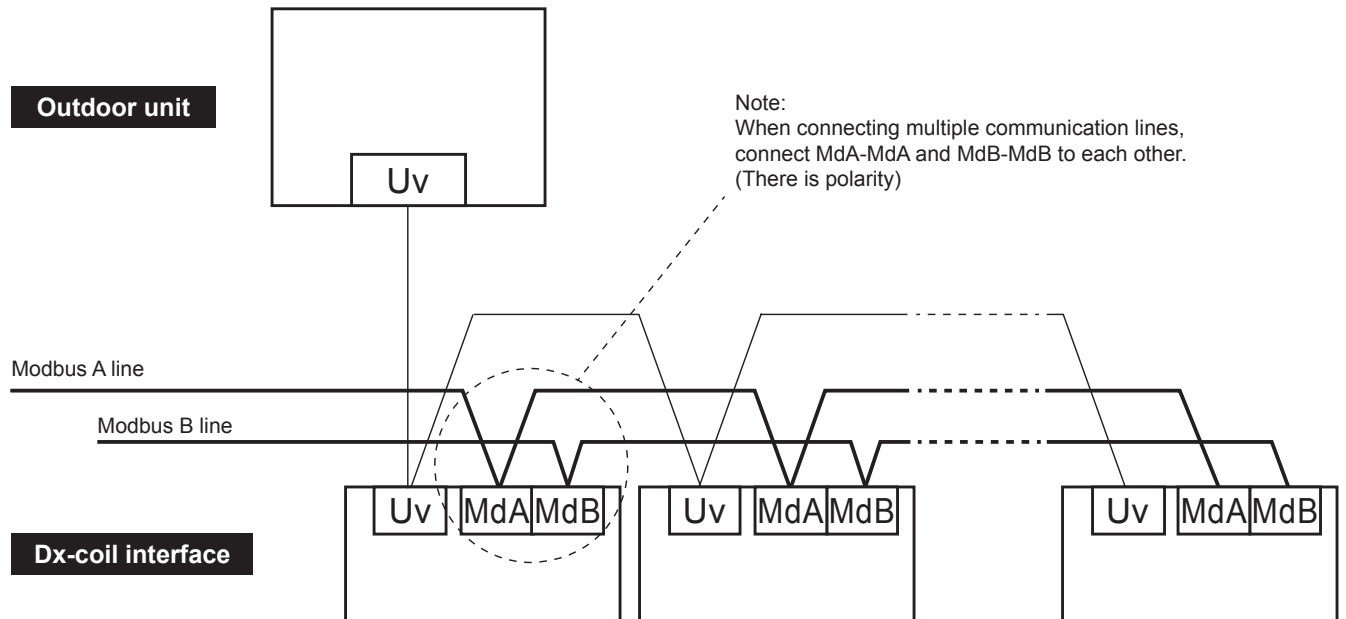

Baud Rate *1	SW506	Bit1: ON / Bit2: OFF (19200)	Bit1: ON / Bit2: OFF (19200)	...	Bit1: ON / Bit2: OFF (19200)
Address *2	SW507	1	2	...	16 (Up to 16)
Termination resistor *3	SW801	Bit1: ON	Bit1: OFF	...	Bit1: OFF

\* 1: Set the baud rate according to the communication device.

\* 2: Up to 16 addresses can be set with the rotary switch.

\* 3: Set the terminating resistor only for the unit with the latest address.

### CAUTION

- RS-485 terminator resistor select switch SW801 (Bit1).
- For SW801 Bit1 (120 ohm), set only the Dx-interface with the latest address, and turn off Bit1 for other Dx-interfaces.

### 2. Function codes

Function code	Sub function code	Function name
0×03	None	Read holding register
0×04	None	Read Input register
0×06	None	White single holding register
0×08	0×00, 01, 02, 04, 0A, 0B, 0C, 0D, 0E, 0F, 11, 12, 14	Diagnostics
0×0B	None	Get Comm. Event Counter
0×0C	None	Get Comm. Event Log
0×10	None	Write multiple holding registers



## 2. Address assignment table

Register	address	Read / Write	Data	Byte
Holding Register	40001	R / W	Operation / stop setting	2
	40002		Operation mode setting	2
	40003		Set temperature setting	2
	40004		Automatic cooling set temperature (Dual set point) setting	2
	40005		Automatic heating set temperature (Dual set point) setting	2
	40006		Fan speed setting	2
	40007		Operation prohibition setting	2
	40008		Analogue Input Capacity Control	2
	40009 ~ 40019		Reserved	
	40020		CN90 DI1 (Safety contact input)	2
	40021		CN90 DI2 (External trouble input)	2
	40022		CN90 DI3 (Forced Thermo OFF input)	2
	40023		CN90 DI4 (Notice input)	2

Register	address	Read / Write	Data	Byte
Input Register	30001	R	Operation / stop setting	2
	30002		Operation mode setting	2
	30003		Set temperature setting	2
	30004		Automatic cooling set temperature (Dual set point) setting	2
	30005		Automatic heating set temperature (Dual set point) setting	2
	30006		Fan speed setting	2
	30007		Operation prohibition setting	2
	30008		Analogue Input Capacity Control	2
	30009 ~ 30019		Reserved	
	30020		CN90 DI1 (Safety contact input)	2
	30021		CN90 DI2 (External trouble input)	2
	30022		CN90 DI3 (Forced Thermo OFF input)	2
	30023		CN90 DI4 (Notice input)	2
	30024 ~ 30039		Reserved	
	30040		TC1	2
	30041		TC2	2
	30042		TCJ	2
	30043		TA	2
	30044		TF	2
	30045		Tx (Auxiliary temperature sensor)	2
	30046		TO	2
	30047 ~ 30059		Reserved	
	30060		Alarm Code	2
	30061		Notice code 1	2
	30062		Notice code 2	2
	30063		Notice code 3	2
	30064		Notice code 4	2
	30065		Notice code 5	2
	30066		Thermostat On Digital Output	2
	30067		Cooling operation signal output / secondary heating signal output	2
	30068		Heating operation signal output	2
	30069		Fan Motor Digital Output	2
	30070		Operating output	2
	30071		Outdoor unit(s) operation level is lower than capacity command	2
30072	Outdoor unit(s) operation level is higher than capacity command	2		



Register	address	Read / Write	Data	Byte
Input Register	30073 ~ 30078	R	Reserved	
	30079		Under restriction of compressor speed due to heat sink overheating in outdoor unit(s)	2
	30080		Cooling / heating start control output	2
	30081		Defrost Mode Digital Output	2
	30082		Pre defrost signal output	2
	30083		Cooling oil recovery / Heating ref recovery	2
	30084 ~ 30099		Reserved	
	30100		Product type setting	2
	30101		Control type	2
	30102		Operation mode range	2
	30103		Fan speed range	2
	30104		Cooling upper limit set temperature	2
	30105		Cooling lower limit set temperature	2
	30106		Heating upper limit set temperature	2
	30107		Heating lower limit set temperature	2
	30108		Dry upper limit set temperature	2
	30109		Dry lower limit set temperature	2
	30110		Automatic mode upper limit set temperature	2
	30111		Automatic mode lower limit set temperature	2
	30112		Dual Set point Function Status	2
	30113		Setting capacity	2
	30114		Modbus band rate SW state	2
	30115		Modbus Slave Address SW state	2
	30116 ~ 30199		Reserved	
	30200		Model name	16
	30201		Model name	
	30202		Model name	
	30203		Model name	
	30204		Model name	
	30205		Model name	
	30206		Model name	
	30207		Model name	
	30208 ~ 30249		Reserved	
	30250		Serial number	16
	30251		Serial number	
	30252		Serial number	
	30253		Serial number	
	30254		Serial number	
	30255		Serial number	
	30256		Serial number	
	30257		Serial number	
	30258 ~ 30299		Reserved	
	30300		Firmware Definition (Firmware control number)	4
	30301		Firmware Definition (Firmware control number)	
30302	Software Version	2		

## ■ DN setting

### Basic procedure

**Be sure to stop the air conditioner before making settings.**

(Change the setup while the air conditioner is not working.)

### ⚠ CAUTION

Set only the Code No. shown in the following table: Do NOT set any other Code No.

If a Code No. not listed is set, it may not be possible to operate the air conditioner or other trouble with the product may result.

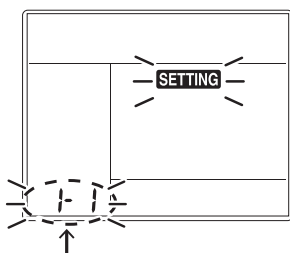
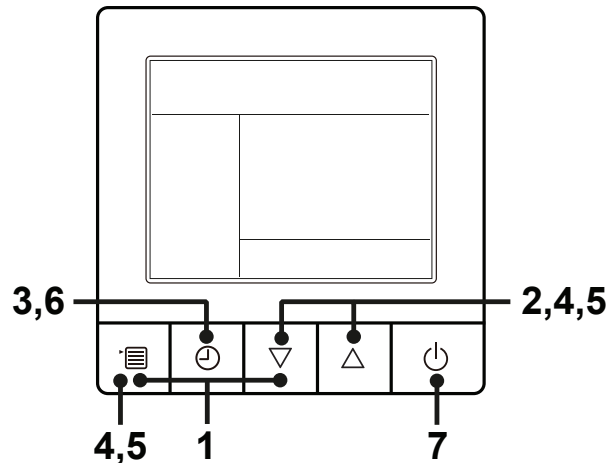

Indoor UNIT No.

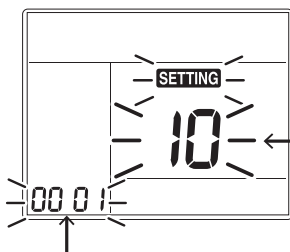

Set data

Code No.

- 1 Press and hold menu button and [▽] setting button simultaneously for 10 seconds or more.**
  - After a while, the display flashes as shown in the figure. “ALL” is displayed as indoor unit numbers during initial communication immediately after the power has been turned on.
- 2 Each time [▽] [△] setting button is pressed, indoor unit numbers in the group control change cyclically.**

**Select the indoor unit to change settings for.**

  - The fan of the selected indoor unit runs and the louvers start swinging. The indoor unit can be confirmed for which to change settings.
- 3 Press OFF timer button to confirm the selected indoor unit.**
- 4 Press the menu button to make Code No. [\*\*] flash. Change Code No. [\*\*] with [▽] [△] setting button.**
- 5 Press the menu button to make Set data [\*\*\*\*] flash. Change Set data [\*\*\*\*] with [▽] [△] setting button.**
- 6 Press OFF timer button to complete the set up.**
  - To change other settings of the selected indoor unit, repeat from Procedure 4.



**7 When all the settings have been completed, press ON/OFF button to finish the settings. (Return to the normal mode)**

“ **SETTING** ” flashes and then the display content disappears and the air conditioner enters the normal stop mode. (The remote controller is unavailable while “ **SETTING** ” is flashing.)

- To change settings of another indoor unit, repeat from Procedure **1**.

**NOTE**

The following changes are settings to be configured by installation and service personnel. If they are set incorrectly, trouble such as the product becoming inoperable may occur.

Set the following DN code according to the horsepower of the Dx-coil interface and the model name of the Valve kit.

1. Dx-coil interface horsepower (HP)

Dx-coil capacity	8HP	10HP	12HP	14HP	16HP	18HP	20HP
Capacity code (DN11)	0021	0023	0024	0025	0026	0027	0028

Dx-coil capacity	24HP	28HP	32HP	34HP	36HP	38HP	40HP
Capacity code (DN11)	0031	0047	0035	0048	0037	0049	0039

2. Valve kit type name specification (This is basically set automatically).

Valve kit model	40VA010V8-ATEE	40VA020V8-ATEE
Code (DN) 4AE	0001	0002

**Notice code signal setting (Terminal DI4 / \*DI4: Notice code Input)**

**[Function]**

- Enter the Notice code when you want to report an abnormality that does not stop the air conditioner from the outside.
- Used by switching functions with settings of Code No. (DN Code).
- Notice code is continuously issued while input signal is ON.
- 201 is displayed in the Notice code history when there is input in DI4.

**[Setup method]**

\* Set data corresponding to Notice code to be used to one of Code No. 180 to 189, in accordance with following table. In case where data other than 0000 is already set, set to other Code No. (DN Code).

Code No. (DN)	Set data	Notice code display
0180 ~ 189	0000	None (Factory default)
	0129	201 (DI4 / *DI4 Notice input ON)
	0134	206 (Tx sensor*1 trouble)

\* 1: Refer to the Service Manual for support.

\* It may take up to ten minutes to be displayed on remote controller after Notice code is issued.

# 5. Test run

## ■ Before test run

---

Before turning on the power supply, carry out the following procedure.

1. By using an insulation tester (500 VMΩ), check that resistance of 1 MΩ or more exists between the terminal block L to N and the earth (grounding). If resistance of less than 1 MΩ is detected, do not run the unit.
2. Check the valve of the outdoor unit being opened fully.
  - To protect the compressor at activation time, leave power-ON for 12 hours or more before operating.
  - Do not press the electromagnetic contactor to forcibly perform a test run. (This is very dangerous because the protective device does not work.)

### CAUTION

---

Be careful of the long - time forced operation because it may result in break.  
Perform the test run check with cooling/heating, and check that it is satisfactory with the whole system.

---

# 6. Trouble shooting

## ■ Confirmation and check

If a problem occurs with the air conditioner, the OFF timer indicator alternately shows the check code and the indoor UNIT No. in which the problem occurred.

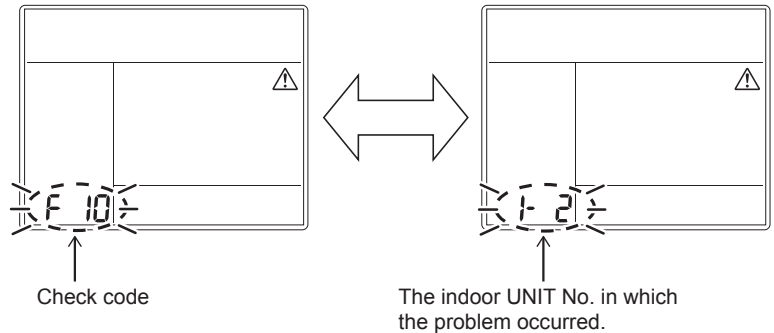

## ■ Troubleshooting history and confirmation

You can check the troubleshooting history with the following procedure if a problem occurs with the air conditioner. (The troubleshooting history records up to 4 incidents.)

You can check it during operation or when operation is stopped.

- If you check the troubleshooting history during OFF timer operation, the OFF timer will be cancelled.

Procedure	Description of operation	
<p style="text-align: center;"><b>1</b></p>	<p>Press the OFF timer button for over 10 seconds and the indicators appear as an image indicating the troubleshooting history mode has been entered. If [Service check] is displayed, the mode enters in the troubleshooting history mode.</p> <ul style="list-style-type: none"> <li>• [01: Order of troubleshooting history] appears in the temperature indicator.</li> <li>• The OFF timer indicator alternately shows the [check code] and the [indoor UNIT No.] in which the problem occurred.</li> </ul>	
<p style="text-align: center;"><b>2</b></p>	<p>Each time the setting button is pressed, the recorded troubleshooting history is displayed in sequence. The troubleshooting history appears in order from [01] (newest) to [04] (oldest).</p> <p><b>⚠ CAUTION</b></p> <p>In the troubleshooting history mode, DO NOT press the Menu button for over 10 seconds, doing so deletes the entire troubleshooting history of the indoor unit.</p>	
<p style="text-align: center;"><b>3</b></p>	<p>After you have finished checking, press the ON/OFF button to return to the regular mode.</p> <ul style="list-style-type: none"> <li>• If the air conditioner is operating, it remains operated even after the ON/OFF button has been pressed. To stop its operation, press the ON/OFF button again.</li> </ul>	

### ▼ Common Check Codes

- E01 No master remote controller, faulty remote controller communication**  
The header remote controller has not been set.  
Check the remote controller inter-unit tie cable (A/B).
- E09 Duplicated master remote controller**  
Two remote controllers have been set master remote controller.  
Check the remote controller inter-unit tie cable (A/B).
- F01 TCJ sensor trouble**  
Check connection of TCJ sensor connector and wiring.  
Check resistance characteristics of TCJ sensor.  
Check for trouble in indoor P.C. board.
- F02 TC2 sensor trouble**  
Check connection of TC2 sensor connector and wiring.  
Check resistance characteristics of TC2 sensor.  
Check for trouble in indoor P.C. board.
- F03 TC1 sensor trouble**  
Check connection of TC1 sensor connector and wiring.  
Check resistance characteristics of TC1 sensor.  
Check for trouble in indoor P.C. board.  
Check whether the TC1 sensor is correctly installed in its place.
- F10 TA sensor trouble**  
Check the connection of TA sensor connector and wiring.  
Check resistance characteristics of TA sensor.  
Check for trouble in indoor P.C. board.
- F11 TF sensor trouble**  
Check connection of TF sensor connector and wiring.  
Check resistance characteristics of TF sensor.  
Check for trouble in indoor P.C. board.
- L02 Outdoor units model disagreement trouble**  
Check outdoor unit model.  
(Check whether the outdoor unit corresponds to Dx-coil interface or not.)
- L09 Indoor unit Capacity Code incorrect**  
Check the settings of DN Code 11.
- L22 Incompatible group combination of indoor units**  
Check indoor units model name.  
Check for trouble in indoor P.C. board.
- L30 External trouble**  
Check the operation monitoring of the fan at terminals \*DI2 / DI2. If this contact is “CLOSED”, the check code “L30” is generated.
- P10 Safety contact trouble**  
Check the contact at terminals \*DI1 / DI1. If the contact is “OPEN”, the check code “P10” is generated.  
If this contact is not used, a bridge connection should be installed on the terminals \*DI1 / DI1.

For the check code other than the above, refer to the service manual.



---

## **Installation Manual**

### **Model name:**

#### **Dx-coil controller**

**40VAM--C8FATEE**

**(Terminal block without relay)**

**40VAMR-C8FATEE**

**(Terminal block with relay)**

#### **Dx-valve kit**

**40VA010V8-ATEE**

**40VA020V8-ATEE**



1 135451 001