



Commercial Air Conditioners



CAS

Air Cooled Scroll Chillers

8 TR - 72 TR

- ✓ Energy Efficient
- ✓ Cost Saving
- ✓ Wide Capacity Range

1. Nomenclature

CAS-XX

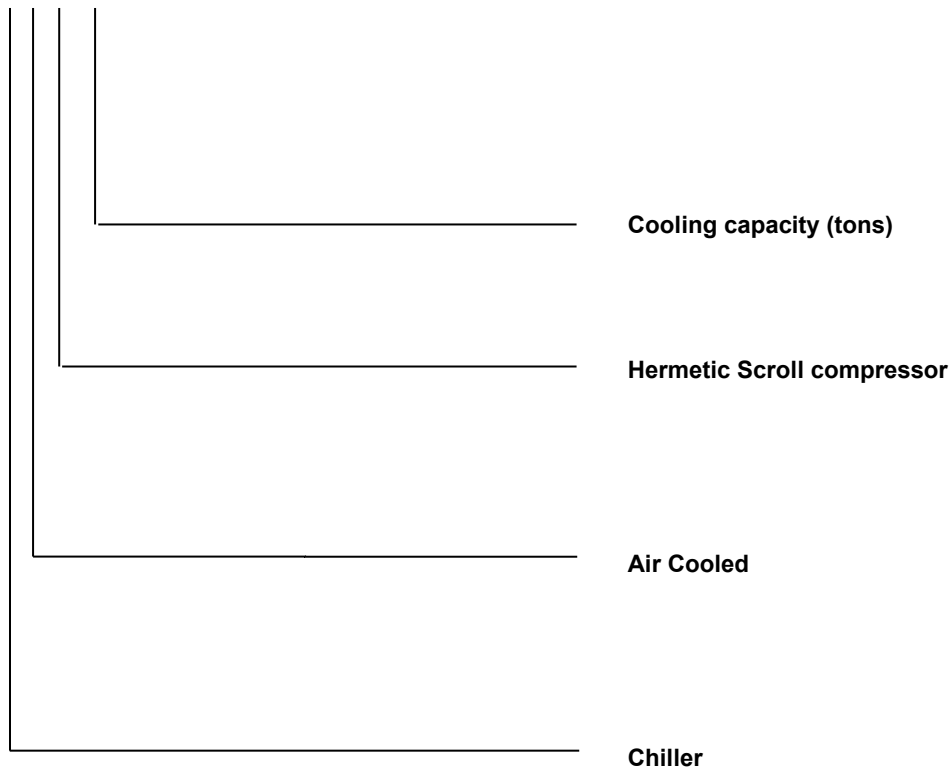

2. Product Lineup

No	Model	Refrigerant	Net dimension	Net weight	Power supply
			W×H×D (mm)	(kg)	
1	CAS-08	R410A	1020×1770×980	276	380-415/3/50
2	CAS-10	R410A	1020×1770×980	320	380-415/3/50
3	CAS-20	R410A	2000×1770×960	530	380-415/3/50
4	CAS-24	R410A	2000×1770×960	645	380-415/3/50
5	CAS40	R410A	2200×2060×1120	935	380-415/3/50
6	CAS-60	R410A	2850×2110×2000	1730	380-415/3/50
7	CAS-72	R410A	3800×2130×2000	2450	380-415/3/50

3. External Appearance



**CAS-08
CAS-10**



**CAS-20
CAS-24**



CAS-40



CAS-60



CAS-72

4. Specifications

MODEL		CAS-08	
Cooling Capacity	Tons	7.11	
	BTU/hr.	85,300	
	kW	25	
Heating Capacity		kW	26
Power input	Cooling	kW	8
	Cooling rated current	A	14.8
	Heating	kW	7.95
	Heating rated current	A	15
EER		kW / kW	3.13
COP		kW / kW	3.27
Power supply		V/Ph/Hz	380-415/3/50
Power supply	Manual switch	A	50
	Fuse	A	36
Max. input consumption		kW	11.0
Rated current		A	20.7
Max. starting current		A	121.2
Compressor	Type		Scroll (fixed speed)
	Brand		Danfoss
	Model		HCJ106
	Quantity	Pieces	1
	Capacity	kW	26.1
	Input	kW	8.08
	Rated load Amps(RLA)	A	14.3
	Locked rotor Amp(LRA)	A	121.2
	Refrigerant oil	ml	2460
Refrigerant	Type		R410A
	Refrigerant control		EXV+ capillary
	Weight	kg	3.1
Condenser (Air side)	Type		Fin-coil
	Quantity of fan motor	Pieces	1
	Air flow	$\times 10^3 \text{m}^3/\text{h}$	13.5
	Fan motor rated current	A	3.7
	Fan motor power input	kW	0.8
Evaporator (Water side)	Type		Plate
	Water pressure drop	kPa	77
	Volume	L	1.89
	Water inlet/outlet pipeline inside normal diameter	mm	DN40
	Water flow	m^3/h	4.3
	Max. design pressure	MPa	1
	Water pipe connection type		Flexible joint

MODEL			CAS-08
Dimension	Net(D×H×W)	mm	1020×1770×980
	Packing size(D×H×W)	mm	1070×1900×1030
Weight	Net weight	kg	276
	Operation weight	kg	286
Connection wiring	Power wire	mm ²	10×4+16×1
	Signal wire	mm ²	0.75×3-core with shielding
Control type			Wired controller
Noise level		dB(A)	65
Safety protection device			1) Protection for over-high discharge pressure. 2) Protection for over-low suction pressure. 3) Power supply phase sequence protection. 4) Anti-freezing protection in cooling mode. 5) Anti-freezing protection in Winter. 6) Protection for compressor over current. 7) Protection for compressor overload. 8) Outlet and inlet water temperature difference protection. 9) Compressor discharge temperature protection. 10) Water flow cut-off protection. 11) Sensor malfunction protection. 12) Low ambient temperature drive-up protection 13) Low temperature protection of shell and tube heat exchanger.
Operation water temp		°C	Cooling: 5~17 Heating: 25~50
Ambient temp		°C	Cooling: -10~46 Heating: -15~24

Note: Specifications are based on the following conditions:

Cooling : chilled water inlet/outlet: 12°C / 7°C, and outdoor ambient temp. of 35°C DB.

Heating : heat water inlet/outlet: 40°C / 45°C, and outdoor ambient temp. 7°C DB/6°C WB.

Water side fouling factor: 0.086m²°C /kW.

MODEL		CAS-10	CAS-20	
Cooling Capacity	Tons	9.95	18.48	
	BTU/hr.	119,420	221,780	
	kW	35	65	
Heating Capacity	kW	37	69	
Power input	Cooling	kW	11.5	20.4
	Cooling rated current	A	19.0	36.5
	Heating	kW	11.3	21.5
	Heating rated current	A	20.0	37.2
EER	kW / kW	3.04	3.19	
COP	kW / kW	3.27	3.21	
Power supply	V/Ph/Hz	380-415/3/50	380-415/3/50	
Power supply	Manual switch	A	50	125
	Fuse	A	36	100
Max. Input consumption	kW	14	29	
Rated current	A	27	54.5	
Max. starting current	A	177	260	
Compressor	Type		Scroll (fixed speed)	Scroll (fixed speed)
	Brand		Danfoss	Danfoss
	Model		SH140A4ALC	CH290A4BBA
	Quantity	Piece	1	1
	Capacity	kW	36.8	65.1
	Input	kW	11.3	20.4
	Rate load Amps.(RLA)	A	21.4	44.3
	Locked rotor Amp(LRA)	A	147	260
	Refrigerant oil	ml	3300	6700
Refrigerant	Type		R410A	R410A
	Refrigerant control		EXV+ capillary	EXV+ capillary
	Weight	kg	5.4	11.5
Condenser (Air side)	Type		Fin-coil	Fin-coil
	Quantity of fan motor	Pieces	1	2
	Air flow	×10 ³ m ³ /h	13.5	27
	Fan motor rated current	A	3.7	3.7×2
	Fan motor input	kW	0.8	0.8×2
Evaporator (Water side)	Type		Double-pipe	Shell-tube
	Water pressure drop	kPa	55	30
	Volume	L	10	35
	Water inlet/outlet pipeline inside normal diameter	mm	DN40	DN65
	Water flow	m ³ /h	6	11.2
	Max. design pressure	MPa	1	1
	Water pipe connection type		Flexible joint(Flange)	Flexible joint(Flange)

MODEL			CAS-10	CAS-20
Dimension	Net(DxHxW)	mm	1020x1770x980	2000x1770x960
	Packing size(DxHxW)	mm	1070x1900x1030	2090x1890x1030
Weight	Net weight	kg	320	530
	Operation weight	kg	330	590
Connection wiring	Power wire	mm ²	10x4+16x1	16x4+10x1
	Signal wire	mm ²	0.75x3-core with shielding	0.75x3-core with shielding
Control type			Wired controller	Wired controller
Safety protection device			1) Protection for over-high discharge pressure. 2) Protection for over-low suction pressure. 3) Power supply phase sequence protection. 4) Anti-freezing protection in cooling mode. 5) Anti-freezing protection in Winter. 6) Protection for compressor over current. 7) Protection for compressor overload. 8) Outlet and inlet water temperature difference protection. 9) Compressor discharge temperature protection. 10) Water flow cut-off protection. 11) Sensor malfunction protection. 12) Low ambient temperature drive-up protection 13) Low temperature protection of shell and tube heat exchanger.	
Noise level		dB(A)	65	67
Operation water temp		°C	Cooling: 0~17(Less than 5°C must add antifreeze) Heating: 25~50	
Ambient temp		°C	Cooling: -10~46 Heating: -15~24	

Note: Specifications are based on the following conditions:

Cooling : chilled water inlet/outlet: 12°C / 7°C, and outdoor ambient temp. of 35°C DB.

Heating : heat water inlet/outlet: 40°C / 45°C, and outdoor ambient temp. 7°C DB/6°C WB.

Water side fouling factor: 0.086m²C /kW.

MODEL			CAS-24	CAS-40
Cooling Capacity	Tons		22.75	36.96
	BTU/hr.		272,960	443,560
	kW		80	130
Heating Capacity	kW		85	138
Power input	Cooling	kW	25.8	42.3
	Cooling rated current	A	43.8	73
	Heating	kW	26.5	43
	Heating rated current	A	40.0	74.4
EER	kW / kW		3.1	3.07
COP	kW / kW		3.21	3.21
Power supply	V/Ph/Hz		380-415/3/50	380-415/3/50
Power supply	Manual switch	A	150	200
	Fuse	A	100	150
Max. Input consumption	kW		34.6	59
Rated current	A		65	109
Max. starting current	A		197	308
Compressor	Type		Scroll (fixed speed)	Scroll (fixed speed)
	Brand		Danfoss	Danfoss
	Model		SH184A4ALC	CH290A4BBA
	Quantity	Pieces	2	2
	Capacity	kW	44.7	65.1
	Input	kW	13.7	20.5
	Rate load Amps.(RLA)	A	27.6	44.3
	Locked rotor Amp(LRA)	A	197	260
	Refrigerant oil	ml	3600	6700
Refrigerant	Type		R410A	R410A
	Refrigerant control		EXV+ capillary	EXV+ capillary
	Weight	kg	6.5×2	10.5×2
Condenser (Air side)	Type		Fin-coil	Fin-coil
	Quantity of fan motor	Pieces	2	2
	Air flow	×10 ³ m ³ /h	27	50
	Fan motor rated current	A	3.7×2	4.8×2
	Fan motor input	kW	0.8×2	2.59×2
Evaporator (Water side)	Type		Shell-tube	Shell-tube
	Water pressure drop	kPa	30	40
	Volume	L	47.5	60
	Water inlet/outlet pipeline inside normal diameter	mm	DN65	DN65
	Water flow	m ³ /h	13.8	22.4
	Max. design pressure	MPa	1	1
	Water pipe connection type		Flexible joint(Flange)	Flexible joint(Flange)

MODEL			CAS-24	CAS-40
Dimension	Net(DxHxW)	mm	2000×1770×960	2200×2060×1120
	Packing size(DxHxW)	mm	2090×1890×1030	2250×2200×1180
Weight	Net weight	kg	645	935
	Operation weight	kg	710	1005
Connection wiring	Power wire	mm ²	25×4+16×1	35×4+16×1
	Signal wire	mm ²	0.75×3-core with shielding	0.75×3-core with shielding
Control type			Wired controller	Wired controller
Safety protection device			1) Protection for over-high discharge pressure. 2) Protection for over-low suction pressure. 3) Power supply phase sequence protection. 4) Anti-freezing protection in cooling mode. 5) Anti-freezing protection in Winter. 6) Protection for compressor over current. 7) Protection for compressor overload. 8) Outlet and inlet water temperature difference protection. 9) Compressor discharge temperature protection. 10) Water flow cut-off protection. 11) Sensor malfunction protection. 12) Low ambient temperature drive-up protection 13) Low temperature protection of shell and tube heat exchanger.	
Noise level		dB(A)	67	68
Operation water temp		°C	Cooling: 0~17(Less than 5°C must add antifreeze) Heating: 25~50	
Ambient temp		°C	Cooling: -10~46 Heating: -15~24	Cooling: 15~46 Heating: -15~24

Note: Specifications are based on the following conditions:

Cooling : chilled water inlet/outlet: 12°C / 7°C, and outdoor ambient temp. of 35°C DB.

Heating : heat water inlet/outlet: 40°C / 45°C, and outdoor ambient temp. 7°C DB/6°C WB.

Water side fouling factor: 0.086m²C /kW.

MODEL			CAS-60	CAS-72
Cooling capacity		Tons	56.87	71.08
		BTU/hr.	682,400	853,000
		kW	200	250
Heating capacity		kW	200	270
Power supply		V/Ph/Hz	380-400/3/50	380-400/3/50
Power supply	Manual switch	A	300	450
	Fuse	A	200	300
EER		kW/kW	2.93	3.19
COP		kW/kW	3.27	3.38
Compressor	Type		Fixed scroll	Fixed scroll
	Quantity	Pieces	6	8
	Model		SH140A4ALC	SH120A4ALC
	Brand		Danfoss	Danfoss
	Capacity	kW	34.7	32.6
	Input	kW	10.86	10.28
	Rated load Amps(RLA)	A	21.4	20.7
	Locked rotor Amp(LRA)	A	147	142
Power input	Cooling	kW	63	78.3
	Cooling rated current	A	110	141.9
	Heating	kW	61	80
	Heating rated current	A	107	146
Max. input consumption		kW	78.3	104.9
Max. current		A	150	200
Refrigerant	Type		R410A	R410A
	Weight	Kg	7×6	15×4
	Refrigerant control		EXV+ capillary	EXV+ capillary
Condenser (Air side)	Type		Fin-coil	Fin-coil
	Quantity of fan motor	Pieces	6	8
	Air flow	×10 ³ m ³ /h	72	96
	Fan motor input	kW	0.865×6	0.7×8
Evaporator (Water side)	Type		Shell and tube	Shell and tube
	Water resistance loss	kPa	30	40
	Volume	L	90	131
	Water inlet/outlet pipeline inside diameter	mm	DN80	DN100
		inch	3"	4"
	Water flow	m ³ /h	31.8	43
	Max. design pressure	MPa	1	1
	Water pipe connection type		Flexible joint	Flexible joint
Dimension	Net(D×H×W)	mm	2850×2110×2000	3800×2130×2000
		inch	112.2×83.1×78.7	149.6×83.86×78.74
	Packing(D×H×W)	mm	2980×2260×2135	3900×2200×2100
		inch	117.3×89×84.1	153.54×86.61×82.68

MODEL			CAS-60	CAS-72
Weight	Net weight	kg	1730	2450
	Operation weight	kg	2000	2600
Connection wire	Power wire	mm ² ×No.	75×3+35×2	185×4+70×1
	Signal wire	mm ² ×No.	0.75×3-core with shielding	0.75×3-core with shielding
Control type			Wired controller	Wired controller
Safety protection device			1) Protection for over-high discharge pressure. 2) Protection for over-low suction pressure. 3) Power supply phase sequence protection. 4) Anti-freezing protection in cooling mode. 5) Anti-freezing protection in Winter. 6) Protection for compressor over current. 7) Protection for compressor overload. 8) Outlet and inlet water temperature difference protection. 9) Compressor discharge temperature protection. 10) Water flow cut-off protection. 11) Sensor malfunction protection. 12) Low ambient temperature drive-up protection 13) Low-temperature protection of shell and tube heat exchanger.	
Noise level(semi-anechoic)		dB(A)	70	74
Operation water temp		°C	Cooling: 5~17 Heating: 45~50	Cooling: 0~17(Less than 5°C must add antifreeze) Heating: 22~50
Ambient temp		°C	Cooling: 10~46 Heating: -10~21	Cooling: 10~52 Heating: -10~21

Note:

Please refer to the water flow volume in the above table strictly to design and install.

All the above data is measured base on the following working condition:

1. Cooling mode: water side fouling factor: 0.086m²·°C/kW, chilled water inlet/outlet: 12°C / 7°C, and outdoor ambient temp. 35°C DB.

2. Heating mode: water side fouling factor: 0.086m²·°C/kW, warm water inlet/outlet: 40°C / 45°C, and outdoor ambient temp. 7°C DB/6°C WB.

5. Dimensions

**CAS-08
CAS-10**

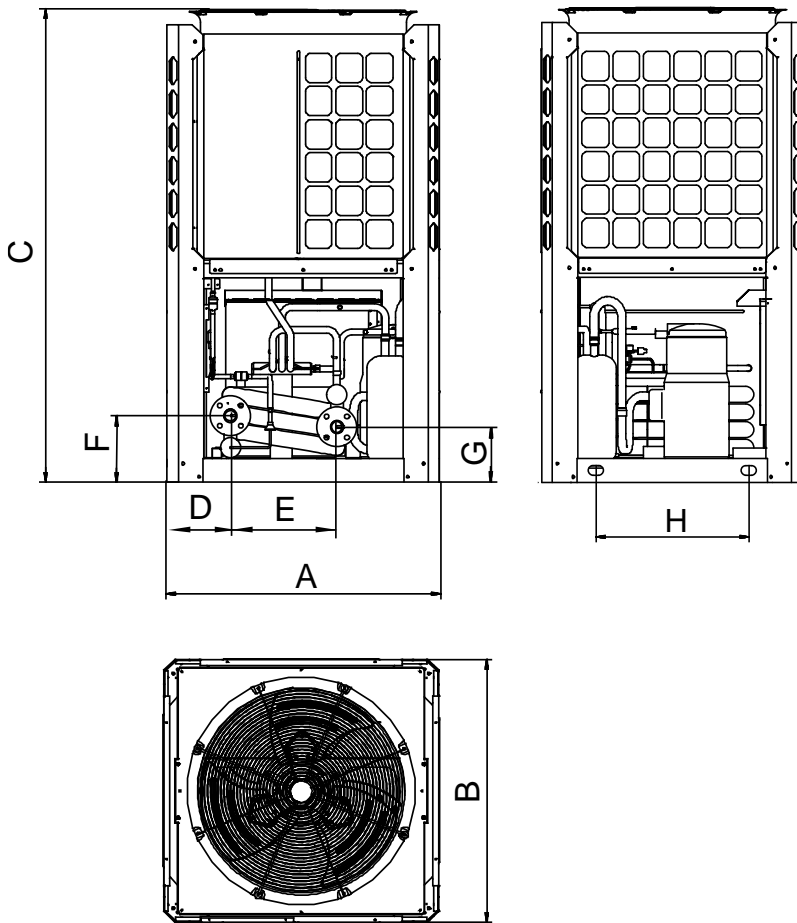

Unit: mm

Model	A	B	C	D	E	F	G	H
CAS-08 CAS-10	1020	980	1770	237	400	250	210	570

**CAS-20
CAS-24**

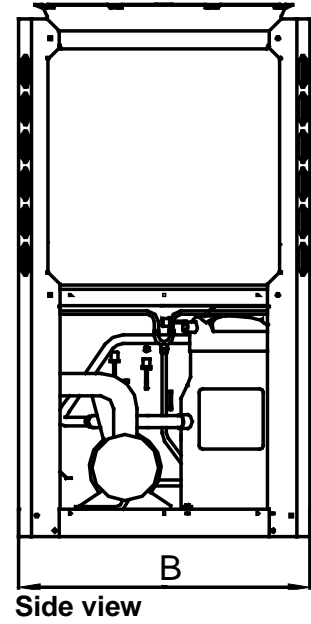
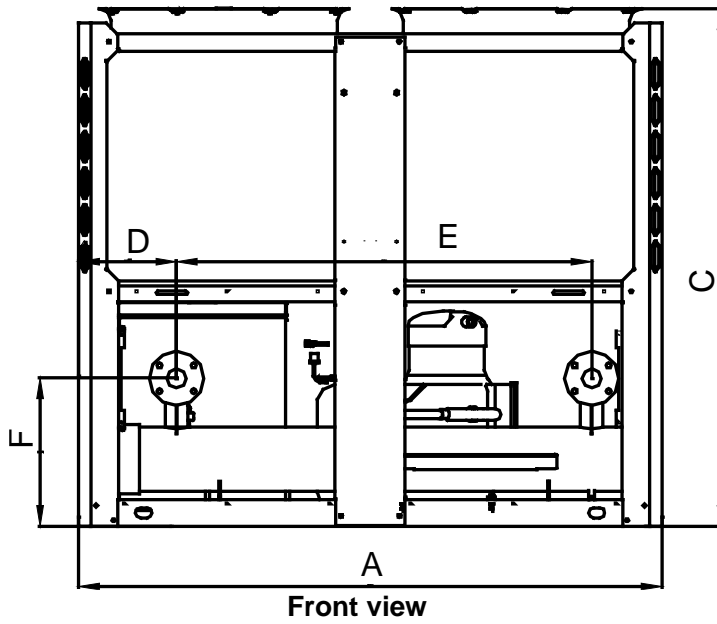

Unit: mm

Model	A	B	C	D	E	F	G	H
CAS-20	2000	960	1770	336	1420	506	1460	862
CAS-24								

CAS-40

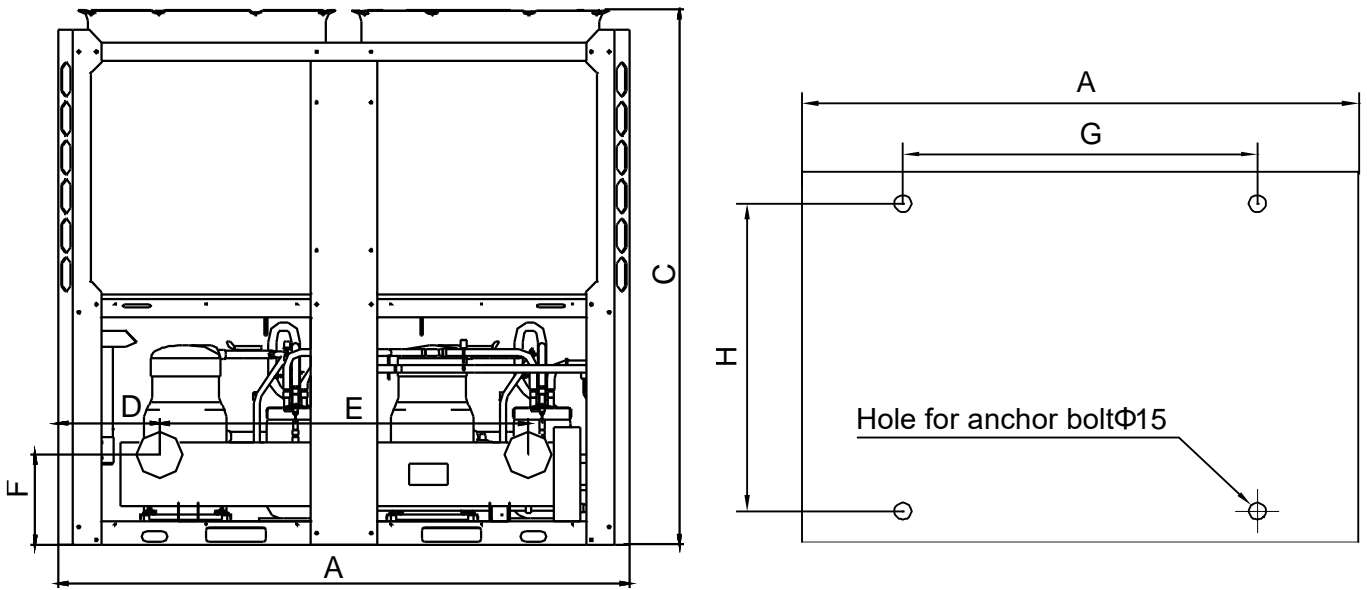

Front view

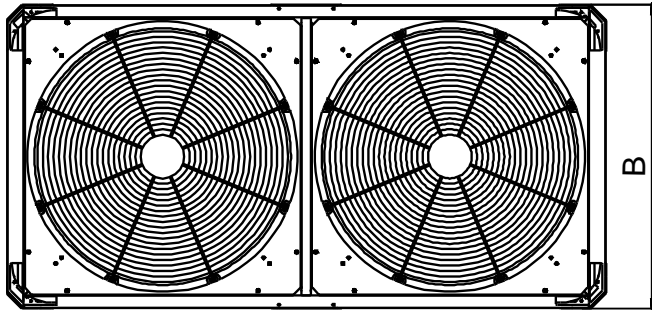

Top view

Unit: mm

Model	A	B	C	D	E	F	G	H
CAS-40	2200	1120	2060	390	1420	347	1460	1017

CAS-60

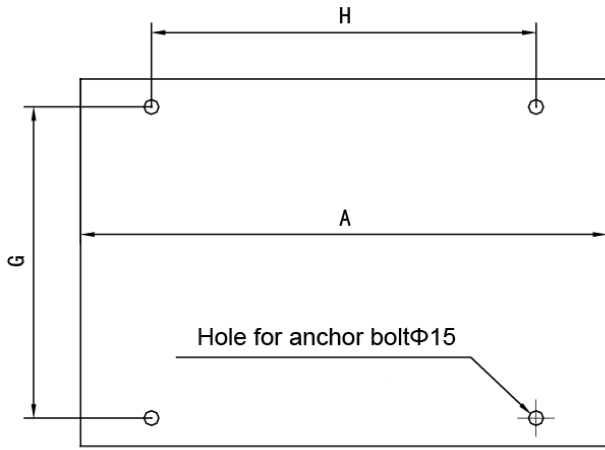
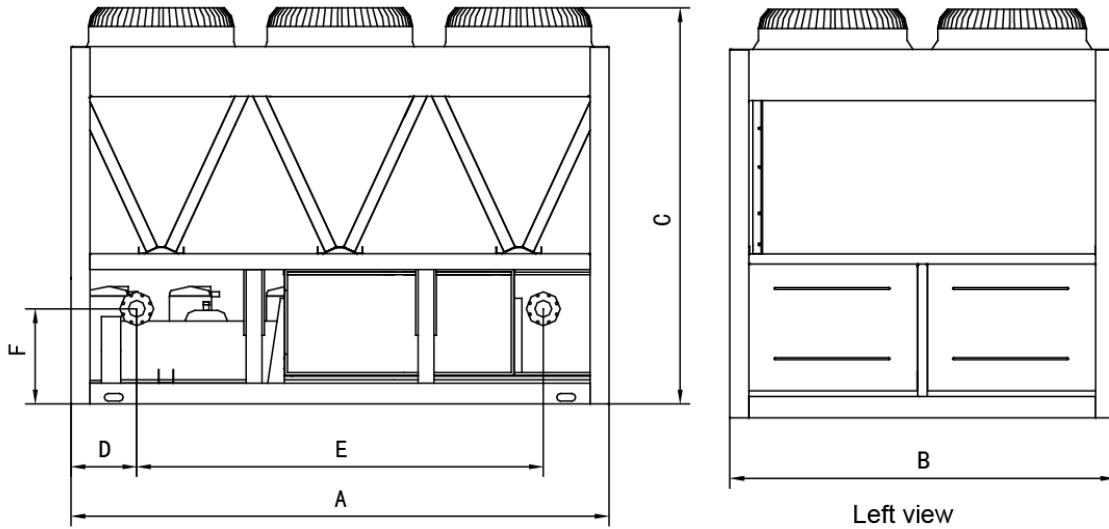

Bottom view

Model	unit	A	B	C	D	E	F	G	H
CAS-60	Mm	2850	2000	2110	3470	2156	506	1888	2388
	inch	112.2	78.74	83.07	136.61	84.88	19.92	74.33	94.02

No.	Name
1	Top cover
2	Compressor
3	Evaporator
4	Water outlet
5	Electric control box
6	Water inlet
7	Condenser

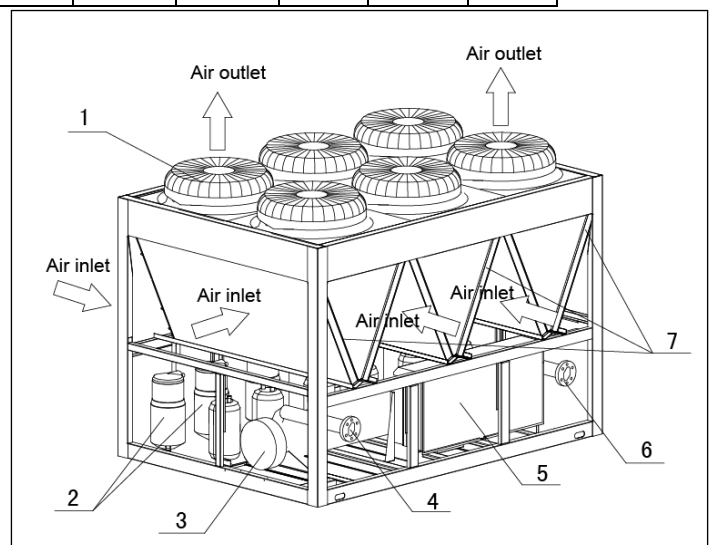

CAS-72

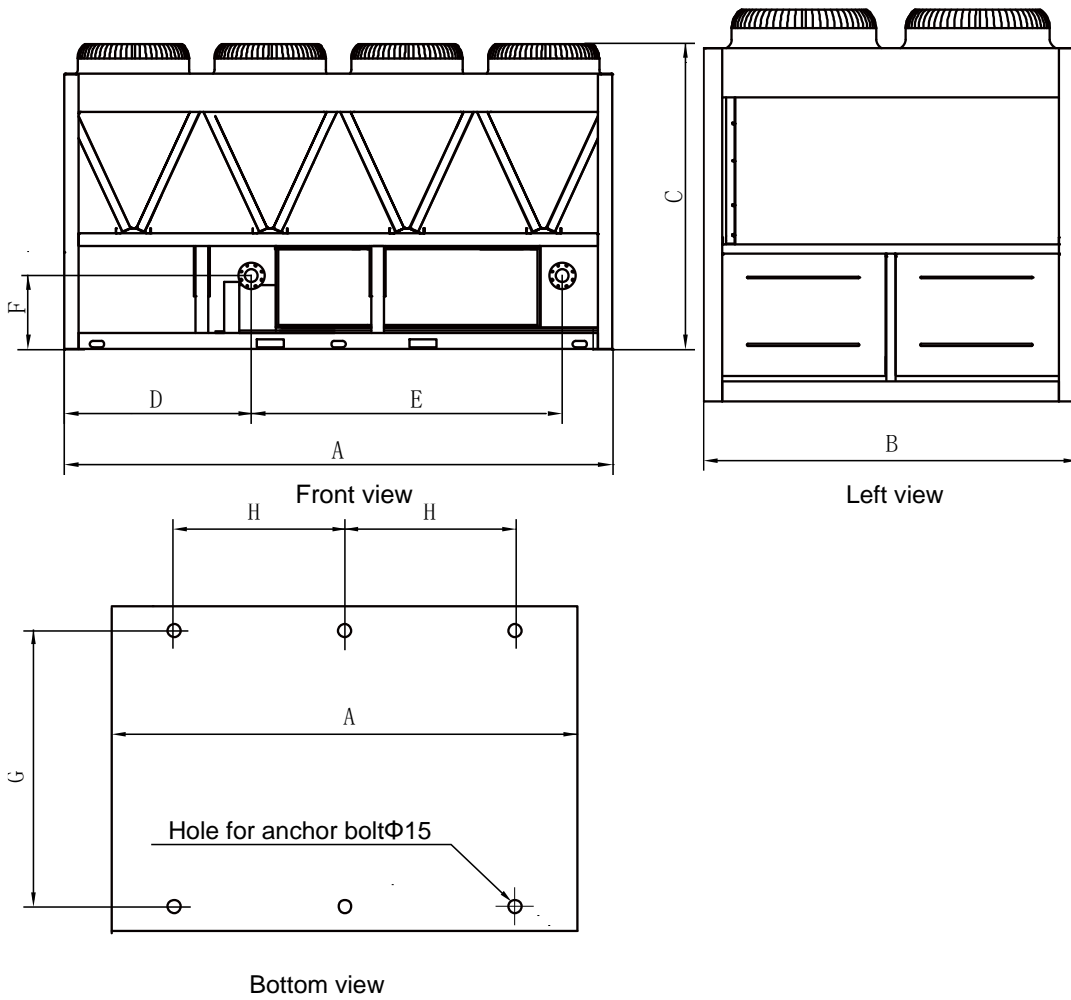

Model	unit	A	B	C	D	E	F	G	H
CAS-72	Mm	3800	2000	2130	1235	2156	573	1888	1551
	inch	149.6	78.74	83.86	48.62	84.88	22.56	74.33	61.06

No.	Name
1	Top cover
2	Compressor
3	Evaporator
4	Water outlet
5	Electric control box
6	Water inlet
7	Condenser
8	Transportation guard plate (Be removed off after installation)

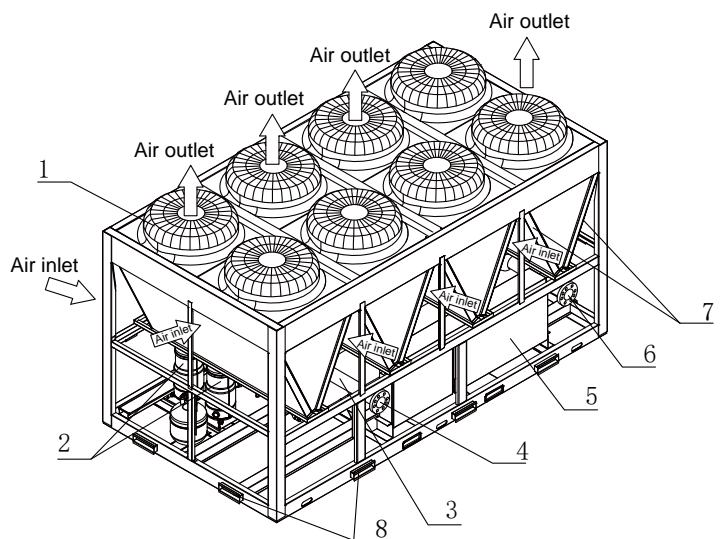

6. Capacity Tables

Cooling

CAS-08

Chilled water outlet temp. (°C)	Ambient temp.(°C)																	
	-10.00		0		10.00		21.00		25.00		30.00		35.00		40.00		46.00	
	Capacity	Power	Capacity	Power	Capacity	Power	Capacity	Power	Capacity	Power	Capacity	Power	Capacity	Power	Capacity	Power	Capacity	Power
	kW	kW	kW	kW	kW	kW	kW	kW	kW	kW	kW	kW	kW	kW	kW	kW	kW	kW
5	33.90	6.43	31.75	6.63	29.78	6.83	27.99	7.05	26.35	7.26	24.86	7.49	23.50	7.72	22.02	8.11	20.26	8.51
6	35.15	6.53	32.88	6.73	30.81	6.94	28.93	7.16	27.22	7.38	25.65	7.60	24.23	7.84	22.72	8.23	20.93	8.64
7	36.48	6.66	34.09	6.87	31.92	7.08	29.94	7.30	28.14	7.53	26.50	7.76	25.00	8.00	23.48	8.40	21.64	8.82
8	37.71	6.86	35.21	7.08	32.94	7.29	30.87	7.52	28.99	7.75	27.27	7.99	25.70	8.24	24.16	8.65	22.30	9.08
9	38.88	6.93	36.27	7.14	33.90	7.37	31.74	7.59	29.77	7.83	27.98	8.07	26.35	8.32	24.80	8.74	22.91	9.17
10	40.47	7.03	37.72	7.25	35.22	7.48	32.94	7.71	30.87	7.95	28.99	8.19	27.27	8.44	25.69	8.87	23.76	9.31
11	41.72	7.10	38.84	7.32	36.23	7.55	33.86	7.78	31.71	8.02	29.74	8.27	27.95	8.53	26.36	8.95	24.41	9.40
12	42.79	7.21	39.80	7.43	37.10	7.66	34.64	7.90	32.40	8.14	30.37	8.39	28.51	8.65	26.92	9.09	24.95	9.54
13	43.68	7.27	40.59	7.49	37.79	7.72	35.26	7.96	32.95	8.21	30.85	8.46	28.94	8.72	27.35	9.16	25.38	9.62
14	44.89	7.32	41.68	7.54	38.77	7.78	36.13	8.02	33.74	8.26	31.56	8.52	29.58	8.78	27.98	9.22	25.99	9.68
15	45.59	7.35	42.29	7.58	39.30	7.81	36.60	8.06	34.14	8.30	31.90	8.56	29.87	8.83	28.29	9.27	26.31	9.73
16	46.85	7.43	43.42	7.66	40.32	7.89	37.51	8.14	34.95	8.39	32.64	8.65	30.53	8.91	28.94	9.36	26.95	9.83
17	47.59	7.46	44.06	7.69	40.87	7.93	37.99	8.18	35.37	8.43	32.99	8.69	30.84	8.96	29.26	9.41	27.27	9.88

Note:

The inlet/outlet water temperature difference is 5°C.

CAS-10

Chilled water outlet temp.	Ambient temp.(°C)											
	21.00		25.00		30.00		35.00		40.00		46.00	
	Capacity	Power	Capacity	Power	Capacity	Power	Capacity	Power	Capacity	Power	Capacity	Power
(°C)	kW	kW	kW	kW	kW	kW	kW	kW	kW	kW	kW	kW
5.00	39.18	10.13	36.90	10.44	34.81	10.76	32.90	11.10	30.83	11.65	28.36	12.23
6.00	40.51	10.29	38.11	10.60	35.92	10.93	33.92	11.27	31.81	11.83	29.30	12.43
7.00	41.92	10.50	39.40	10.82	37.10	11.16	35.00	11.50	32.87	12.08	30.30	12.68
8.00	43.22	10.81	40.58	11.14	38.17	11.49	35.98	11.85	33.82	12.44	31.22	13.06
9.00	44.44	10.92	41.68	11.25	39.18	11.60	36.89	11.96	34.71	12.56	32.08	13.19
10.00	46.12	11.08	43.22	11.42	40.59	11.78	38.18	12.14	35.97	12.75	33.27	13.38
11.00	47.41	11.19	44.39	11.53	41.64	11.89	39.14	12.26	36.90	12.87	34.17	13.52
12.00	48.49	11.35	45.36	11.70	42.51	12.07	39.92	12.44	37.68	13.06	34.93	13.71
13.00	49.36	11.44	46.13	11.80	43.19	12.16	40.52	12.54	38.29	13.16	35.53	13.82
14.00	50.58	11.52	47.23	11.88	44.18	12.25	41.41	12.62	39.17	13.26	36.39	13.92
15.00	51.23	11.58	47.79	11.94	44.67	12.31	41.82	12.69	39.61	13.32	36.83	13.99
16.00	52.51	11.70	48.94	12.06	45.69	12.43	42.74	12.81	40.52	13.46	37.72	14.13
17.00	53.18	11.75	49.52	12.12	46.19	12.49	43.17	12.88	40.97	13.52	38.18	14.20

Note:
The inlet/outlet water temperature difference is 5°C.

CAS-20

Chilled water outlet temp. (°C)	Ambient temp.(°C)											
	21.00		25.00		30.00		35.00		40.00		46.00	
	Capacity kW	Power kW	Capacity kW	Power kW	Capacity kW	Power kW	Capacity kW	Power kW	Capacity kW	Power kW	Capacity kW	Power kW
5.00	72.77	17.97	68.52	18.52	64.64	19.10	61.10	19.69	57.25	20.67	52.67	21.70
6.00	75.23	18.25	70.77	18.81	66.70	19.39	62.99	19.99	59.08	20.99	54.41	22.04
7.00	77.85	18.62	73.17	19.19	68.90	19.79	65.00	20.40	61.04	21.42	56.27	22.49
8.00	80.26	19.18	75.36	19.77	70.90	20.38	66.82	21.01	62.81	22.06	57.97	23.17
9.00	82.52	19.36	77.41	19.96	72.76	20.58	68.51	21.22	64.47	22.28	59.57	23.39
10.00	85.65	19.65	80.27	20.26	75.38	20.89	70.91	21.53	66.80	22.61	61.79	23.74
11.00	88.04	19.85	82.44	20.46	77.33	21.09	72.68	21.75	68.54	22.83	63.47	23.98
12.00	90.06	20.14	84.24	20.76	78.95	21.40	74.13	22.06	69.98	23.17	64.87	24.33
13.00	91.66	20.30	85.67	20.93	80.21	21.57	75.25	22.24	71.11	23.35	65.99	24.52
14.00	93.94	20.44	87.72	21.07	82.05	21.72	76.90	22.40	72.75	23.52	67.58	24.69
15.00	95.15	20.54	88.76	21.18	82.95	21.83	77.67	22.51	73.55	23.63	68.41	24.81
16.00	97.52	20.75	90.88	21.39	84.86	22.05	79.38	22.73	75.25	23.87	70.06	25.06
17.00	98.77	20.85	91.96	21.49	85.79	22.16	80.17	22.84	76.08	23.99	70.91	25.18

Note:
The inlet/outlet water temperature difference is 5°C.

CAS-24

Chilled water outlet temp. (°C)	Ambient temp.(°C)											
	21.00		25.00		30.00		35.00		40.00		46.00	
	Capacity kW	Power kW	Capacity kW	Power kW	Capacity kW	Power kW	Capacity kW	Power kW	Capacity kW	Power kW	Capacity kW	Power kW
5.00	89.56	22.72	84.34	23.43	79.56	24.15	75.20	24.90	70.46	26.14	64.83	27.45
6.00	92.59	23.08	87.10	23.79	82.09	24.53	77.52	25.28	72.71	26.55	66.97	27.88
7.00	95.82	23.55	90.06	24.28	84.80	25.03	80.00	25.80	75.12	27.09	69.26	28.44
8.00	98.78	24.25	92.75	25.00	87.26	25.78	82.24	26.57	77.31	27.90	71.35	29.30
9.00	101.57	24.49	95.28	25.25	89.55	26.03	84.32	26.83	79.35	28.17	73.31	29.58
10.00	105.42	24.86	98.80	25.62	92.77	26.42	87.27	27.23	82.21	28.60	76.04	30.03
11.00	108.36	25.10	101.46	25.88	95.18	26.68	89.45	27.50	84.35	28.88	78.11	30.32
12.00	110.84	25.47	103.68	26.26	97.17	27.07	91.24	27.91	86.13	29.30	79.84	30.77
13.00	112.82	25.67	105.44	26.47	98.72	27.28	92.61	28.13	87.52	29.53	81.22	31.01
14.00	115.62	25.85	107.96	26.65	100.99	27.47	94.65	28.32	89.54	29.74	83.18	31.23
15.00	117.11	25.98	109.24	26.78	102.10	27.61	95.59	28.46	90.53	29.89	84.19	31.38
16.00	120.02	26.24	111.85	27.05	104.44	27.89	97.70	28.75	92.62	30.19	86.23	31.70
17.00	121.56	26.37	113.18	27.18	105.58	28.02	98.67	28.89	93.64	30.33	87.27	31.85

Note:
The inlet/outlet water temperature difference is 5°C.

CAS AIR COOLED CHILLER 50Hz

CAS-40

Chilled water outlet temp.	Ambient temp.(°C)											
	21.00		25.00		30.00		35.00		40.00		46.00	
	Capacity	Power	Capacity	Power	Capacity	Power	Capacity	Power	Capacity	Power	Capacity	Power
(°C)	kW	kW	kW	kW	kW	kW	kW	kW	kW	kW	kW	kW
5.00	145.54	37.25	137.04	38.41	129.29	39.59	122.20	40.82	114.50	42.86	105.34	45.00
6.00	150.46	37.83	141.54	39.00	133.40	40.21	125.97	41.45	118.16	43.53	108.83	45.70
7.00	155.71	38.61	146.34	39.80	137.80	41.03	130.00	42.30	122.07	44.42	112.55	46.64
8.00	160.52	39.76	150.72	40.99	141.79	42.26	133.64	43.57	125.62	45.75	115.95	48.03
9.00	165.05	40.15	154.83	41.39	145.52	42.67	137.02	43.99	128.94	46.19	119.14	48.50
10.00	171.31	40.75	160.55	42.01	150.75	43.31	141.82	44.65	133.59	46.88	123.57	49.23
11.00	176.08	41.15	164.87	42.43	154.66	43.74	145.36	45.09	137.08	47.35	126.93	49.71
12.00	180.11	41.76	168.49	43.05	157.91	44.38	148.27	45.75	139.97	48.04	129.75	50.44
13.00	183.33	42.09	171.33	43.39	160.42	44.73	150.49	46.12	142.22	48.42	131.98	50.84
14.00	187.89	42.38	175.43	43.69	164.11	45.04	153.80	46.44	145.50	48.76	135.17	51.20
15.00	190.30	42.59	177.52	43.91	165.90	45.27	155.34	46.67	147.11	49.00	136.81	51.45
16.00	195.03	43.02	181.76	44.35	169.71	45.72	158.76	47.13	150.50	49.49	140.12	51.97
17.00	197.53	43.23	183.92	44.57	171.57	45.95	160.35	47.37	152.17	49.74	141.82	52.22

Note:
The inlet/outlet water temperature difference is 5°C.

CAS-60

Cooling:

Chilled water outlet temp.	Ambient temp.(°C)											
	21.00		25.00		30.00		35.00		40.00		46.00	
	Capacity	Power	Capacity	Power	Capacity	Power	Capacity	Power	Capacity	Power	Capacity	Power
(°C)	kW	kW	kW	kW	kW	kW	kW	kW	kW	kW	kW	kW
5.00	207.12	55.49	195.03	57.20	183.99	58.97	173.90	60.80	162.94	63.83	149.91	67.03
6.00	214.11	56.35	201.42	58.09	189.84	59.89	179.27	61.74	168.15	64.83	154.87	68.07
7.00	221.59	57.50	208.26	59.28	196.10	61.11	185.00	63.00	173.72	66.15	160.17	69.46
8.00	228.44	59.22	214.49	61.06	201.78	62.94	190.18	64.89	178.77	68.13	165.00	71.54
9.00	234.87	59.80	220.33	61.65	207.08	63.55	194.99	65.52	183.49	68.80	169.54	72.24
10.00	237.19	60.70	222.30	62.57	208.73	64.51	196.36	66.50	184.97	69.83	171.10	73.32
11.00	243.81	61.29	228.28	63.19	214.15	65.14	201.27	67.16	189.80	70.52	175.75	74.04
12.00	249.38	62.19	233.29	64.11	218.64	66.10	205.29	68.14	193.80	71.55	179.65	75.13
13.00	253.84	62.69	237.23	64.63	222.13	66.63	208.37	68.69	196.91	72.12	182.74	75.73
14.00	260.15	63.12	242.91	65.08	227.23	67.09	212.96	69.16	201.46	72.62	187.15	76.25
15.00	263.49	63.43	245.79	65.40	229.71	67.42	215.09	69.50	203.69	72.98	189.43	76.63

Note:

The inlet/outlet water temperature difference is 5°C.

CAS-72**Cooling:**

Chilled water outlet temp. (°C)	Ambient temp.(°C)													
	21.00		25.00		30.00		35.00		40.00		46.00		52.00	
	Capacity	Power	Capacity	Power	Capacity	Power	Capacity	Power	Capacity	Power	Capacity	Power	Capacity	Power
	kW	kW	kW	kW	kW	kW	kW	kW	kW	kW	kW	kW	kW	kW
5.00	279.89	68.96	263.55	71.09	248.63	73.29	235.00	75.56	220.20	79.34	202.58	83.30	182.32	87.47
6.00	289.34	70.03	272.19	72.20	256.54	74.43	242.25	76.73	227.23	80.57	209.28	84.60	188.56	88.83
7.00	299.44	71.46	281.43	73.67	265.00	75.95	250.00	78.30	234.75	82.22	216.44	86.33	195.23	90.64
8.00	308.70	73.61	289.86	75.88	272.68	78.23	257.00	80.65	241.58	84.68	222.98	88.92	201.35	93.36
9.00	317.40	74.32	297.75	76.62	279.84	78.99	263.50	81.43	247.95	85.50	229.11	89.78	207.11	94.27
10.00	329.43	75.44	308.75	77.77	289.90	80.17	272.72	82.65	256.90	86.79	237.64	91.13	215.06	95.68
11.00	338.62	76.18	317.06	78.53	297.43	80.96	279.54	83.47	263.61	87.64	244.10	92.02	221.15	96.62
12.00	346.37	77.29	324.01	79.68	303.66	82.15	285.13	84.69	269.16	88.92	249.52	93.37	226.31	98.04
13.00	352.55	77.91	329.49	80.32	308.51	82.81	289.41	85.37	273.49	89.64	253.80	94.12	230.45	98.82
14.00	361.32	78.45	337.37	80.88	315.59	83.38	295.78	85.96	279.80	90.26	259.94	94.77	236.28	99.51
15.00	365.96	78.84	341.38	81.28	319.05	83.79	298.73	86.38	282.90	90.70	263.10	95.24	239.42	100.00

Note:

The inlet/outlet water temperature difference is 5°C.

7. Installation

7.1 Unit Installation

7.1.1 Transportation

The angle of inclination should not be more than 15° when carrying the unit, to avoid overturn of the unit.

a. Rolling handling: several rolling rods of the same size are placed under the base of the unit, and the length of each rod must be more than the outer frame of the base and suitable for balancing of the unit.

b. Lifting: the strength lifting rope (belt) can bear should be 4 times the weight of the unit. Check the lifting hook and ensure that it is firmly attached to the unit, and the lifting angle should be more than 60° . To avoid damages to the unit, the contact position of the unit and lifting rope should be provided with an at least 50mm thick wood block, cloth or hard paper. Any person is not allowed to stand below the unit when lifting it.

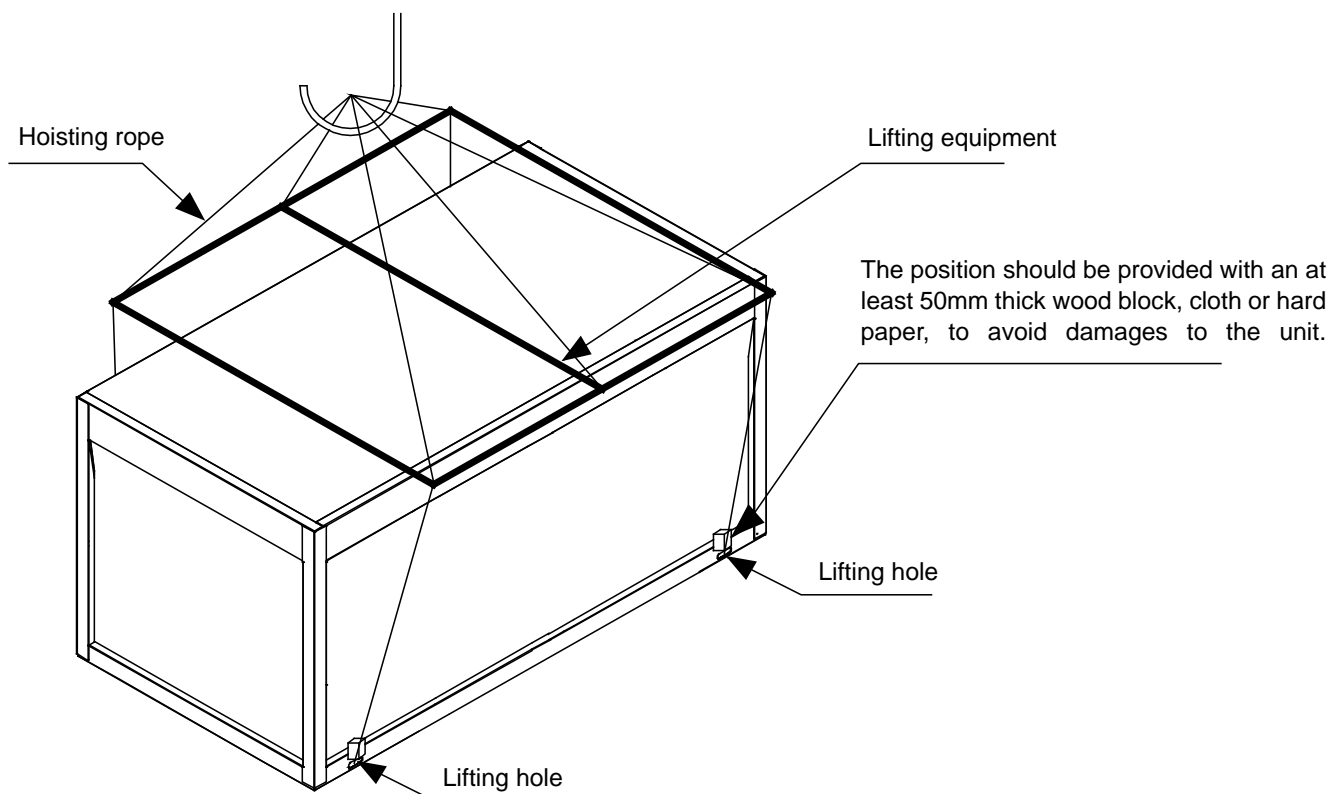

7.1.2 Installation space

• Requirements of arrangement space of the unit

1) To ensure adequate airflow entering the condenser, the influence of descending airflow caused by the high-rise buildings around upon the unit should be taken into account when installing the unit.

2) If the unit is installed where the flowing speed of air is high, such as on the exposed roof, the measures including sunk fence and Persian blinds can be taken, to prevent the turbulent flow from disturbing the air entering the unit. If the unit needs to be provided with sunk fence, the height of the latter should not be more than that of the former; if Persian blinds are required, the total loss of static pressure should be less than the static pressure outside the fan. The space between the unit and sunk fence or Persian blinds should also meet the requirement of the minimum installation space of the unit.

3) If the unit needs to operate in winter, and the installation site may be covered by snow, the unit should be located higher than the snow surface, to ensure that air flows through the coils smoothly.

CAS-08, 10, 20, 24, 40

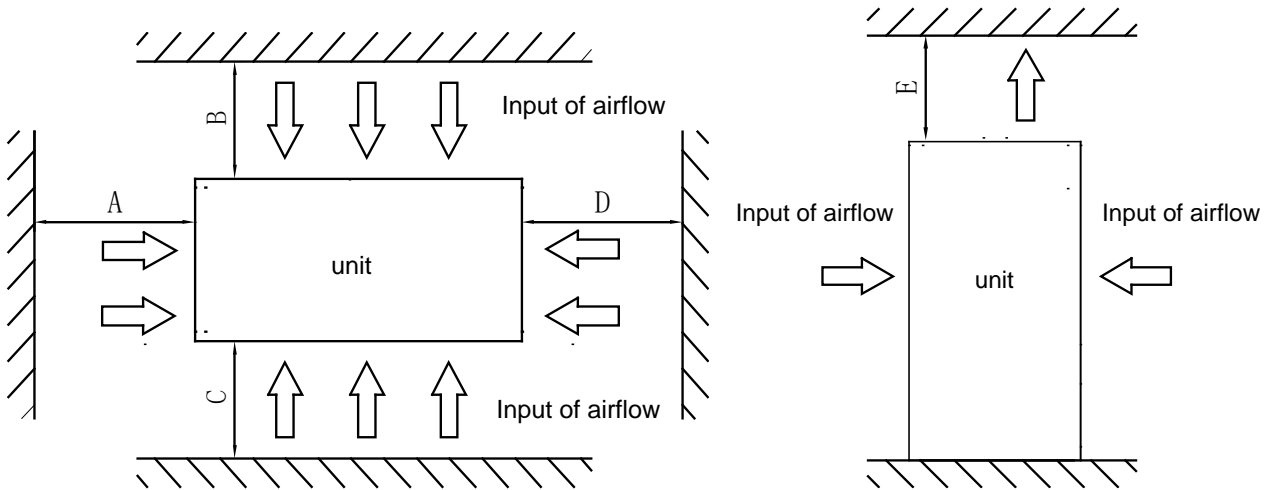

The recommend space parameter

Series	Module	Installation space (mm)				
		A	B	C	D	E
CAS	CAS-08	≥1500	≥2000	≥2000	≥1500	≥8000
	CAS-10					
	CAS-20					
	CAS-24					
	CAS-40					
	CAS-60	≥2000	≥2000	≥2000	≥8000	
	CAS-72					

• Space requirements for parallel installation of multiple scroll units

To avoid back flow of the air in the condenser and operational faults of the unit, the parallel installation of multiple scroll units can follow the direction A and D as shown in the figure above, the spaces between the unit and the obstacle are given in the figure above, and the space between adjacent scroll units should not be less than 300mm; the installation can also follow the direction B and C as shown in the figure above, the spaces between the unit and the obstacle are given in the figure above, and the space between adjacent scroll units should not be less than 600mm; the installation can also follow the direction combination of A and D, and B and C, the spaces between the unit and the obstacle are given in the figure above, the space between adjacent scroll units in the direction A and D should not be less than 300mm, and the space between adjacent scroll units in the direction B and C should not be less than 600mm.

If the spaces mentioned above cannot be met, the air passing from the unit to the coils may be restricted, or back flow of air discharge may occur, and the performance of the unit may be affected, or the unit may fail to operate.

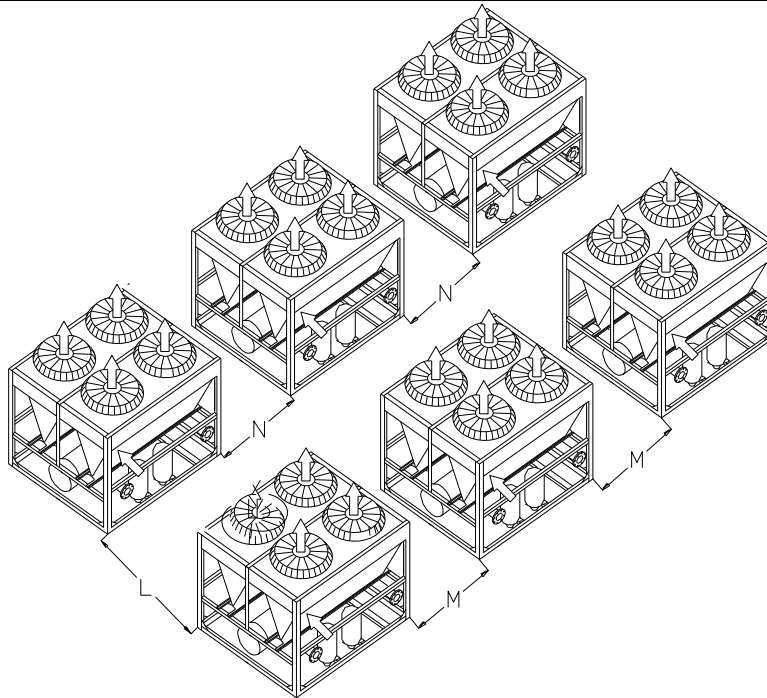

Series	Model	Max unit combined quantity	L(mm)	M(mm)	N(mm)
CAS	CAS-08	16	≥600	≥300	≥300
	CAS-10	16	≥600	≥300	≥300
	CAS-20	16	≥600	≥300	≥300
	CAS-24	16	≥600	≥300	≥300
	CAS-40	16	≥600	≥300	≥300
	CAS-60	5	≥600	≥300	≥300
	CAS-72	8	≥600	≥300	≥300

7.1.3 Installation foundation

- The unit should be located on the horizontal foundation, the ground floor or the roof which can bear operating weight of the unit and the weight of maintenance personnel. Refer to the operating weight parameters in specification table.
- If the unit is located so high that it is inconvenient for maintenance personnel to conduct maintenance, the suitable scaffold can be provided around the unit.
- The scaffold must be able to bear the weight of maintenance personnel and maintenance facilities.
- The bottom frame of the unit is not allowed to be embedded into the concrete of installation foundation.

Location drawing of installation foundation of the unit (unit: mm)

CAS-08, CAS-10

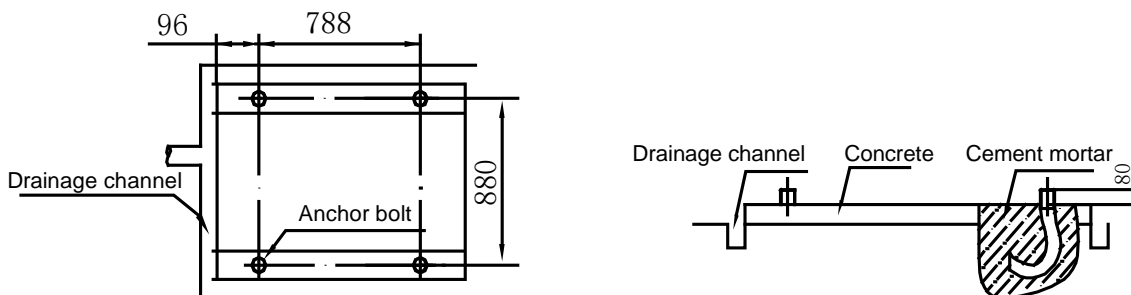

CAS-20, CAS-24

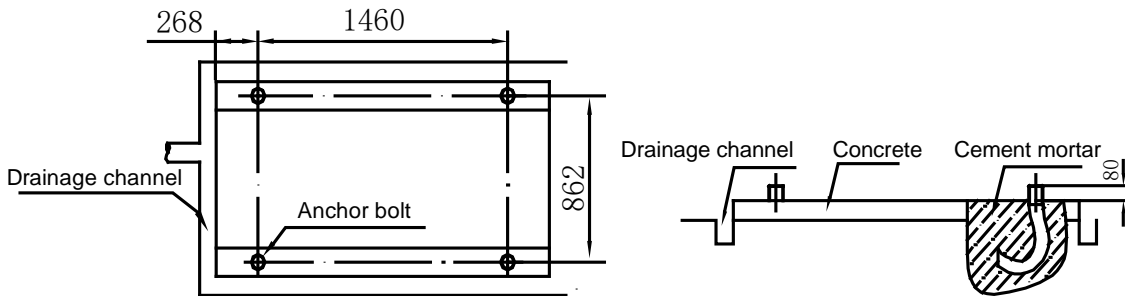

CAS-40

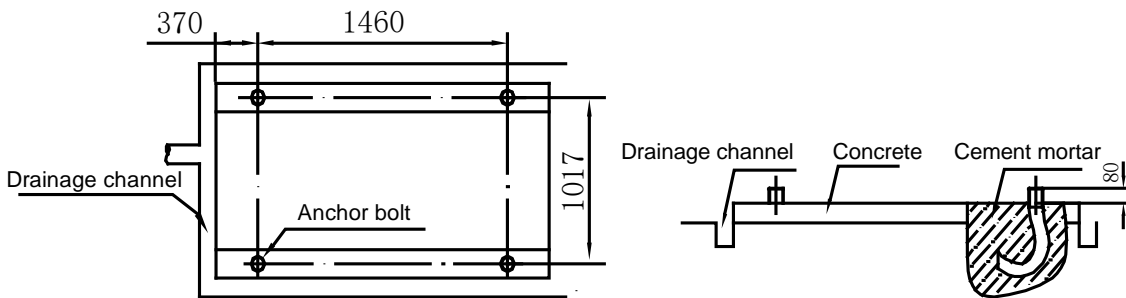

CAS-60

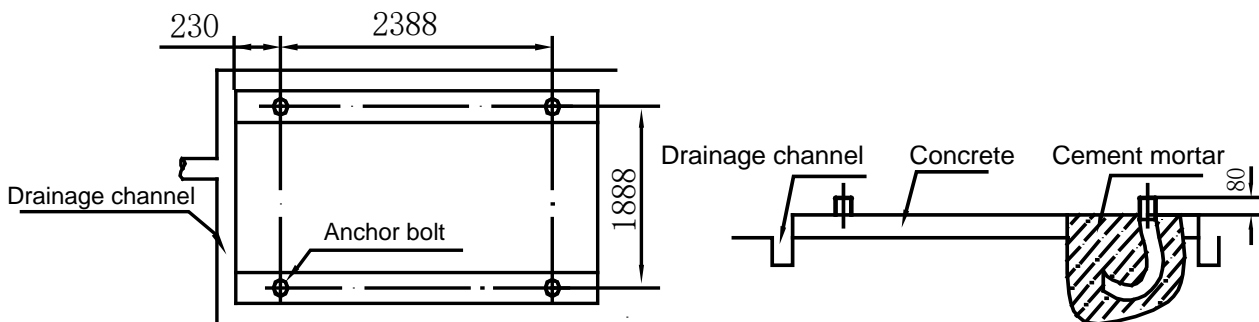

CAS-72

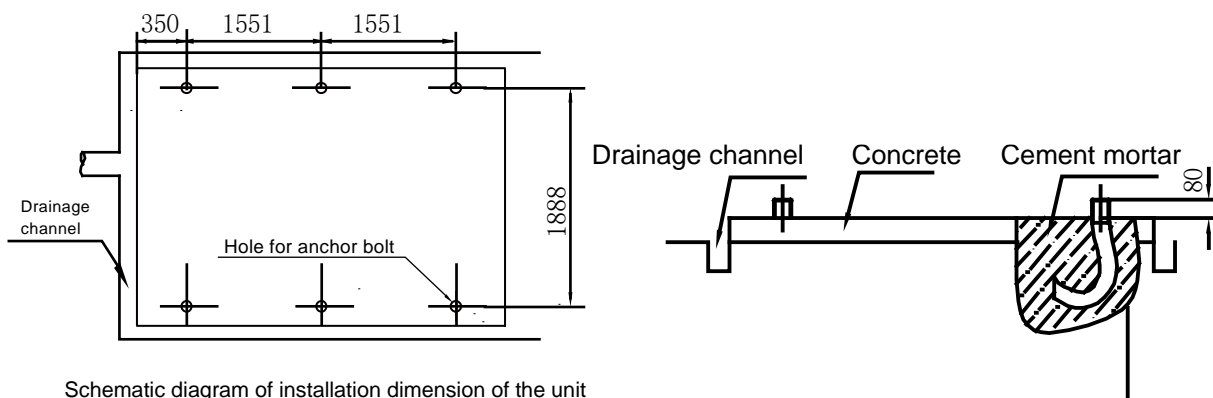

Schematic diagram of installation dimension of the unit

Load distribution

Unit: kg

Series	Model	R1	R2	R3	R4	R5	R6
CAS	CAS-08	62	70	67	75	/	/
	CAS-10	81	81	89	89	/	/
	CAS-20	140	130	170	150	/	/
	CAS-24	170	210	170	160	/	/
	CAS-40	200	320	230	370	/	/
	CAS-60	567	433	567	433	/	/
	CAS-72	373	344	487	462	539	395

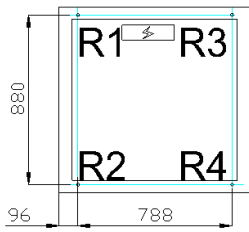

CAS-08

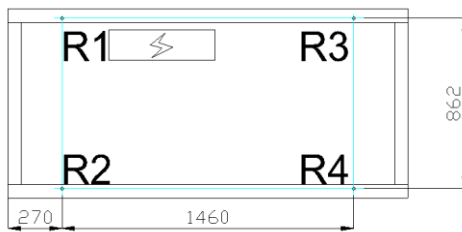

CAS-20,24

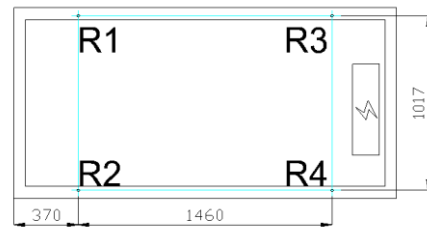

CAS-40

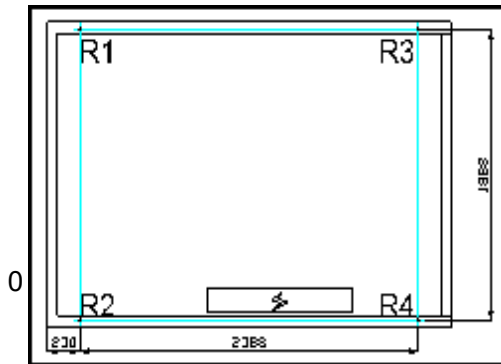

CAS-60

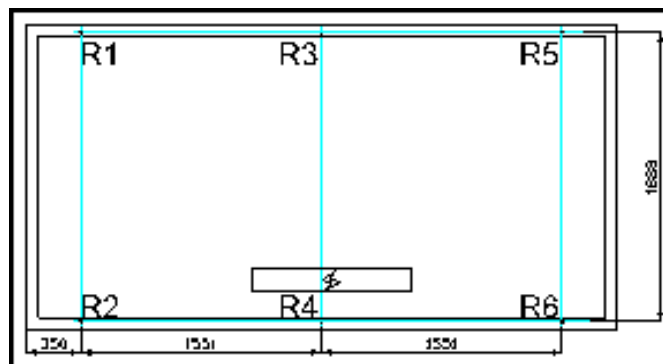

CAS-72

7.1.4 Installation of damping devices

※ Damping devices must be provided between the unit and its foundation.

By means of the $\Phi 15\text{mm}$ diameter installation holes on the steel frame of the unit base, the unit can be fastened on the foundation through the spring damper. See figure above (Schematic diagram of installation dimension of the unit) for details about center distance of the installation holes. The damper does not go with the unit, and the user can select the damper according to the relevant requirements. When the unit is installed on the high roof or the area sensitive to vibration, please consult the relevant persons before selecting the damper.

※ Installation steps of the damper

Step	Content
1	Make sure that the flatness of the concrete foundation is within $\pm 3\text{mm}$, and then place the unit on the cushion block.
2	Raise the unit to the height suitable for installation of the damping device. Remove the clamp nuts of the damper.
3	Place the unit on the damper, and align the fixing bolt holes of the damper with the fixing holes on the unit base.

4	Return the clamp nuts of the damper to the fixing holes on the unit base, and tighten them into the damper.
5	Adjust the operational height of the damper base, and screw down the leveling bolts. Tighten the bolts by one circle to ensure equal height adjustment variance of the damper.
6	The lock bolts can be tightened after the correct operational height is reached.

7.2 Water System Installation

Notice:

- After the unit is in place, chilled water pipes can be laid.
- The relevant installation regulations should be abided with when conducting connection of water pipes.
- The pipelines should be free of any impurity, and all chilled water pipes must conform to local rules and regulations of pipeline engineering.

7.2.1 Connection requirements of chilled water pipes

- a. All chilled water pipelines should be thoroughly flushed, to be free of any impurity, before the unit is operated. Any impurity should not be flushed to or into the heat exchanger.
- b. Water must enter the heat exchanger through the inlet; otherwise the performance of the unit will decline.
- c. The inlet pipe of the evaporator must be provided with a water flow switch, to realize flow-break protection for the unit. Both ends of the water flow switch must be supplied with horizontal straight pipe sections whose diameter is 5 times that of the inlet pipe. The water flow switch must be installed in strict accordance with "Installation & Regulation Guide for Water flow switch". The wires of the water flow switch should be led to the electric cabinet through shielded cable. The working pressure of the water flow switch is 1.0MPa, and its interface is 1 inch in diameter. After the pipelines are installed, the water flow switch will be set properly according to the rated water flow of the unit.
- d. The pump installed in the water pipeline system should be equipped with starter. The pump will directly press water into the heat exchanger of the water system.
- e. The pipes and their ports must be independently supported but should not be supported on the unit.
- f. The pipes and their ports of the heat exchanger should be easy to disassemble for operation and cleaning, as well as inspection of port pipes of the evaporator.
- g. The evaporator should be provided with a filter with more than 40 meshes per inch at site. The filter should be installed near to the inlet port as much as possible, and be insulated.
- h. The by-pass pipes and by-pass valves as shown in the figure of "**Connection drawing of pipeline system**" must be mounted for the heat exchanger, to facilitate cleaning of the outside system of water passage before the unit is adjusted. During maintenance, the water passage of the heat exchanger can be cut off without disturbing other heat exchangers.
- i. The flexible ports should be adopted between the interface of the heat exchanger and on-site pipeline, to reduce transfer of vibration to the building.

j. To facilitate maintenance, the inlet and outlet pipes should be provided with thermometer or manometer. The unit is not equipped with pressure and temperature instruments, so they need to be purchased by the user.

k. All low positions of the water system should be provided with drainage ports, to drain water in the evaporator and the system completely; and all high positions should be supplied with discharge valves, to facilitate discharging air from the pipeline. The discharge valves and drainage ports should not be insulated to facilitate maintenance.

l. All possible water pipes in the system to be chilled should be insulated, including inlet pipes and flanges of the heat exchanger.

m. The outdoor chilled water pipelines should be wrapped with an auxiliary heating belt freeze protection, and the material of the auxiliary heat belt should be PE, EDPM, etc., with thickness of 20mm, to prevent the pipelines from freezing and thus cracking under low temperature. The power supply of the heating belt should be equipped with an independent fuse.

n. When the ambient temperature is lower than 2°C, and the unit will be not used for a long time, water inside the unit should be drained. If the unit is not drained in winter, its power supply should not be cut off, and the fan coils in the water system must be provided with three-way valves, to ensure smooth circulation of the water system when the anti-freezing pump is started up in winter.

o. The common outlet pipelines of combined units should be provided with mixing water temperature sensor.

Warning:

- For the water pipeline network including filters and heat exchangers, dreg or dirt may seriously damages the heat exchangers and water pipes.
- The installation persons or the users must ensure the quality of chilled water, and de-icing salt mixtures and air should be excluded from the water system, since they may oxidize and corrode steel parts inside the heat exchanger.

7.2.2 Connection drawing of pipeline system

CAS-08/ CAS-10/ CAS-20/ CAS-24/ CAS-40/ CAS-60/ CAS-72

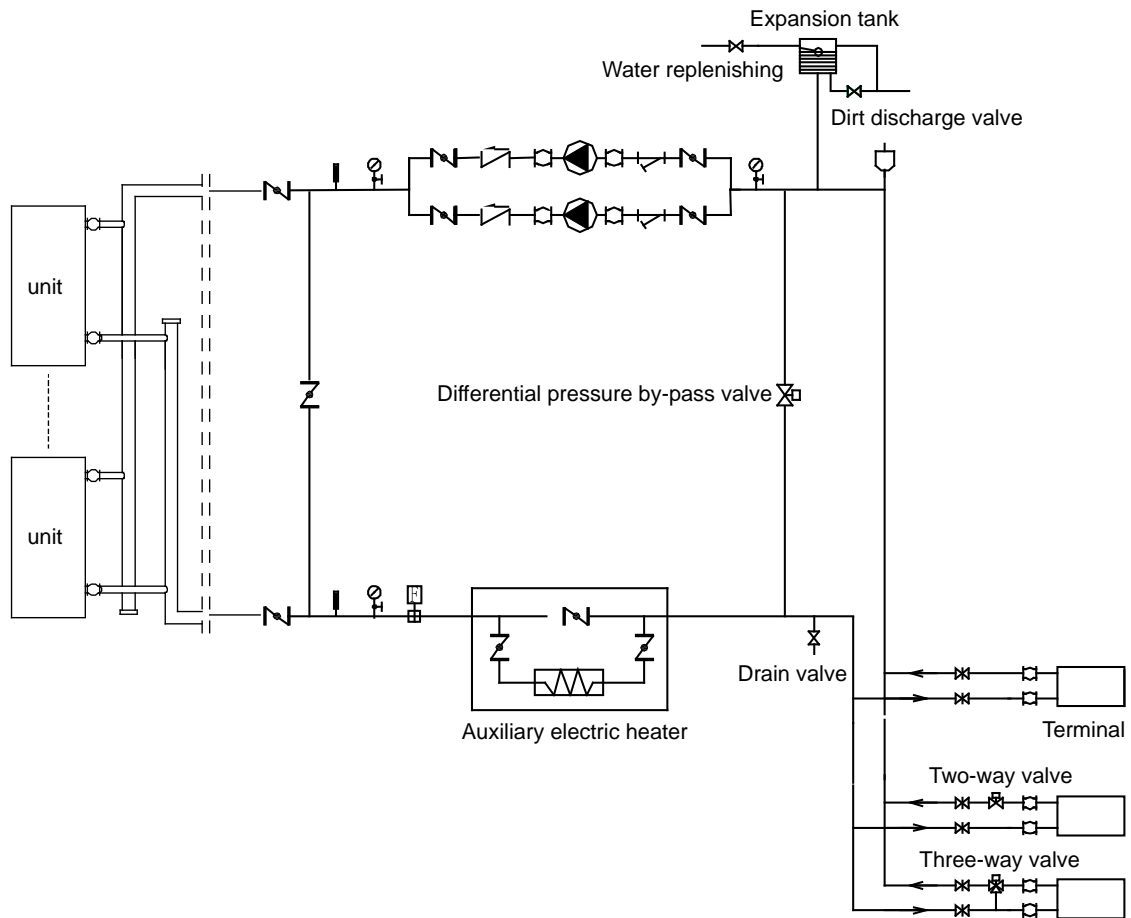

Symbol explanation				
Stop valve	Pressure gauge	Water flow switch	Gate valve	Flexible joint
Y-shaped filter	Thermometer	Circulating pump	Check valve	Automatic discharge valve



Eminent Air (Thailand) Co., Ltd.
405 Moo 5 Soi Soonthonvasu,
Bhudharaksa Road, Preakasamai,
Muang, Samutprakarn ,10280 Thailand

Tel. +662 744-6777
Fax: +662 749-3034 or 35
E-mail: info@eminent.co.th
Website: www.eminent.co.th



Air Cooled Scroll Chillers 120617

"Eminent Air reserves the right to modify product details and specifications without prior notice, in accordance with our policy of ceaseless product improvement."