



SELF-CONTAINED ^{R-22}

Air Cooled Air Conditioners 7.5-20 Tons
SRUB R22 Series 50Hz

TRANE
TECHNOLOGIES





Self-Contained Air Cooled Air Conditioner

No Water Required

You will find the efficiency, flexibility, and unobtrusive styling of the SRUB models. The SRUBs are hard to be beaten especially for the scarce water in the local area, and high-rise office buildings. The SRUB get along fine without cooling by water. And this is another kind of Trane products which can serve the requirement in nearly every application.

Designed For You

- Light and compact.
- Available in 7.5, 9, 10.5, 13.5, 16, 18 and 20 ton capacity.
- The cabinet is thermally and acoustically insulated to make it even quieter.

Quality and Reliability

- Scroll compressors are available from 7.5 to 20 tons with excellent reliability and high efficiency.
- Dual compressors and independent circuits are standard in the SRUB160-SRUB250 models.
- All units are 100 percent run tested prior to leaving the production line.

Maximum Efficiency

- Lower noise operation and higher efficiency with the new generation higher EER Scroll Compressor.
- 64% fewer parts than a comparable capacity reciprocating compressor.
- Single rotating assembly minimizes the friction and mechanical losses.
- Smooth operation, similar to a centrifugal compressor, give low torque variation and extend motor life, and minimal vibration reducing wear.
- Solid mount with no internal suspension to be worn out.
- Integral inlet dirt separator removes contaminants.
- Rolling element bearings for higher efficiency reduced friction. No suction or discharge valves for improved efficiency compared to a reciprocating compressor.

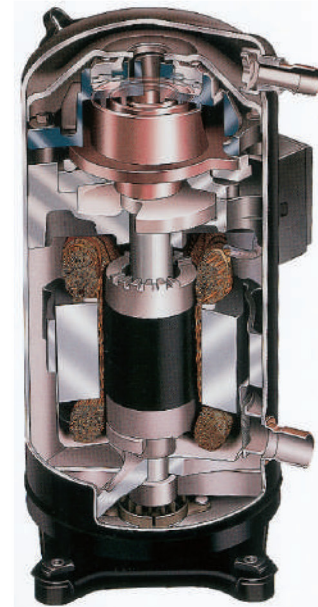

System Advantage

- Factory assembly reduces installation costs - no field assembly is needed.
- No need for external heat ex-changers, water towers and other space requirement.
- Simply choose the location, install properly ducting, arrange drain piping and make electrical connection.
- Horizontal and vertical discharge arrangement.
- Quick-access panels for fast and easy servicing.
- Fully refrigerant charge R22.

System Performance Matrix

Model	Evaporator CFM	Condenser CFM	Total Capacity (MBH)	Sensible Capacity (MBH)
SRUB 080	2,800	4,500	87	61
SRUB 110	3,600	5,500	110	73
SRUB 130	4,400	5,500	127	92
SRUB 160	5,200	8,000	165	113
SRUB 190	6,200	9,000	194	141
SRUB 220	7,200	10,000	213	159
SRUB 250	8,300	11,000	251	184

Note: 1. Matched system ratings are per ARI condition. Full load ratings are at 95°F entering condenser air temperature, and 80/67°F air dry bulb/wet bulb entering the air handler coil.
 2. Evaporator fan power accounts for ARI condition required external static pressure, and losses associated with air filters, casing and wet evaporator coil pressure drop.

Product Specifications

UNIT MODELS		SRUB080AD	SRUB110AD	SRUB130AD	SRUB160BD	SRUB190BD	SRUB220BD	SRUB250BD
POWER CONNECTION	V/ph/Hz	380-415/3/50	380-415/3/50	380-415/3/50	380-415/3/50	380-415/3/50	380-415/3/50	380-415/3/50
MCA ¹	A	26.15	32.74	36.37	33.61	57.61	61.11	75.28
SYSTEM DATA								
Refrigerant Type		R22	R22	R22	R22	R22	R22	R22
No. Refrigerant Circuits		1	1	1	2	2	2	2
EVAPORATOR COIL								
Tube Size OD	in	3/8	3/8	3/8	3/8	3/8	3/8	3/8
Fins per inch		12	12	12	12	12	12	14
Refrigerant Flow Control		Expansion valve	Expansion valve	Expansion valve	Expansion valve	Expansion valve	Expansion valve	Expansion valve
Drain Connection Size	in	1	1	1	1	1	1	1
Drain Connection Type		Steel - MPT	Steel - MPT	Steel - MPT	Steel - MPT	Steel - MPT	Steel - MPT	Steel - MPT
EVAPORATOR FAN								
Fan Type		Double Inlet Centrifugal with Forward Curved Wheel						
Qty		1	1	1	1	1	2	2
Drive Type		Belt drive						
Nominal Airflow ²	cfm (cmh)	2800 (4757)	3600 (6116)	4400 (7476)	5200 (8835)	6200 (10534)	7200 (12233)	8300 (14102)
EVAPORATOR MOTOR								
Motor Type		Totally Enclosed-Fan Cooled, Three Phase Induction Motor						
Qty		1	1	1	1	1	1	1
Motor Output	hp (kW)	1 (0.75)	2 (1.5)	2 (1.5)	3 (2.2)	3 (2.2)	3 (2.2)	5.5 (4.0)
V/ph/Hz		380-415/3/50	380-415/3/50	380-415/3/50	380-415/3/50	380-415/3/50	380-415/3/50	380-415/3/50
RLA		1.99	3.67	3.67	4.90	4.90	4.90	8.56
COMPRESSOR								
Compressor Type		Hermetic Scroll						
Qty		1	1	1	2	1 - 1	2	2
RLA		16.4	19.2	19.6	16.4	16.4/19.2	19.2	19.6
CONDENSER COIL								
Tube Size OD	in	3/8	3/8	3/8	3/8	3/8	3/8	3/8
Fins per inch		12	12	12	12	12	12	14
CONDENSER FAN								
Fan Type		Double Inlet Centrifugal with Forward Curved Wheel						
Qty		1	2	2	2	2	2	2
Drive Type		Belt drive						
Nominal Airflow ²	cfm (cmh)	4500 (7646)	5500 (9345)	5500 (9345)	8000 (13592)	9000 (15291)	10000 (16990)	11000 (18689)
CONDENSER MOTOR								
Motor Type		Totally Enclosed-Fan Cooled, Three Phase Induction Motor						
Qty		1	1	1	1	1	1	1
Motor Output	hp (kW)	2 (1.5)	3 (2.2)	3 (2.2)	5 (3.7)	5 (3.7)	5 (3.7)	7.5 (5.5)
No. of Speed		1	1	1	1	1	1	1
V/ph/Hz		380-415/3/50	380-415/3/50	380-415/3/50	380-415/3/50	380-415/3/50	380-415/3/50	380-415/3/50
RLA		3.66	5.08	5.08	8.03	8.03	8.03	12.0
FILTER								
Type		Washable Aluminum Air Filter						
Qty		2	1 + 2	1 + 2	3	3	3	3
DIMENSION (HxWxD)								
Crated (Shipping)	mm	2083x1320x965	2083x1740x850	2083x1740x850	2502x1790x965	2502x1790x965	2502x2057x965	2502x2057x965
Uncrated (Net)	mm	1955x1295x965	1955x1700x845	1955x1700x845	2375x1765x965	2375x1765x965	2375x2030x965	2375x2030x965
WEIGHT								
Uncrated (Net)	kg	522	638	678	814	968	1062	1070

Note : Product design and specification are subject to change without notice.

¹ MCA - Minimum Circuit Ampacity

² CFM is rated with standard air-dry coil

Unit Configurations

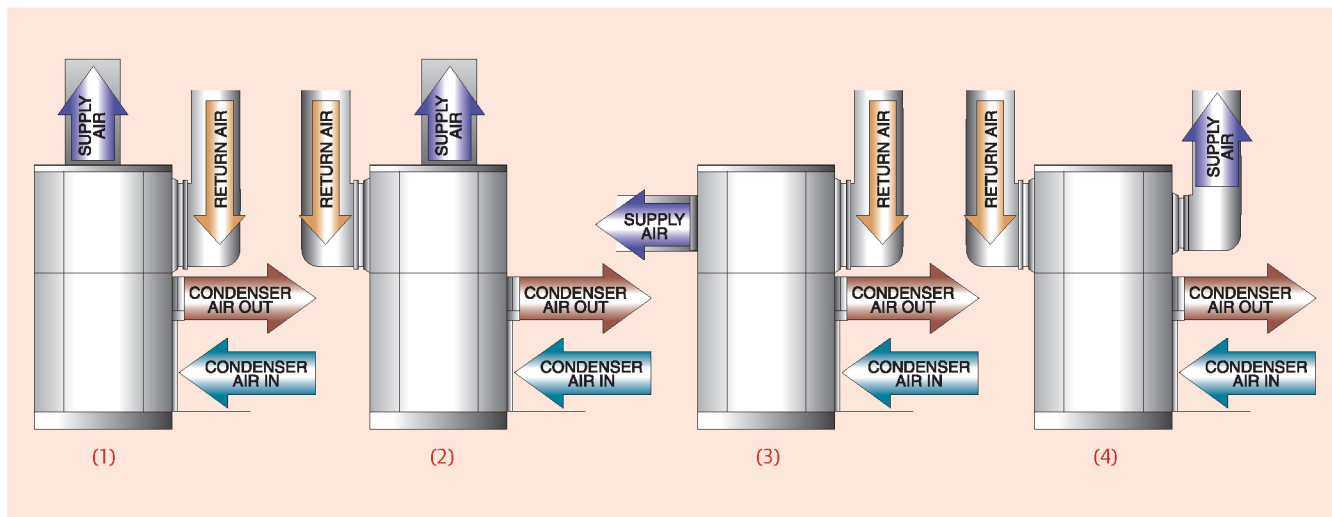

Feature Summary

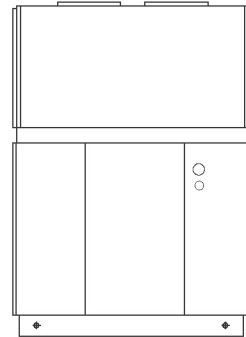
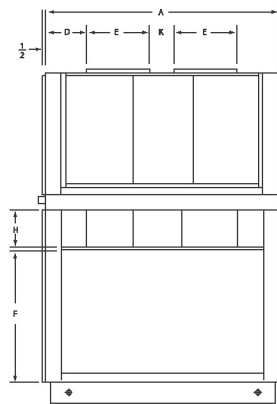
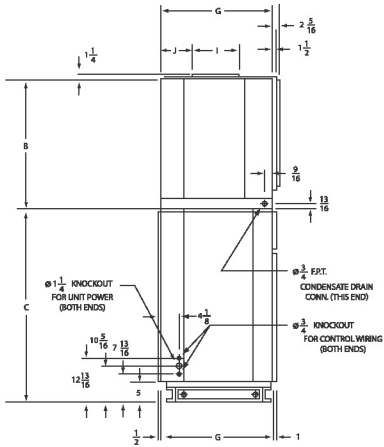

EVAPORATOR SECTION

SRUB080-190 has 1 evaporator blower.
SRUB220-250 has 2 evaporator blowers.

CONDENSING SECTION

SRUB080 has 1 condenser blower.
SRUB110-250 has 2 condenser blowers.

MODEL	A	B	C	D	E	F	G	H	I	J	K
SRUB 080	50 1/2	29 1/2	54	16 1/16	18 7/8	29 1/8	36 7/16	9	13 7/8	7 1/2	-
SRUB 110/130	67	29 1/2	47	24 1/16	18 7/8	29 1/8	31 3/4	9	13 7/8	7 1/2	-
SRUB 160/190	69	34 3/4	58	25 1/16	18 7/8	39 1/16	36 3/4	10	16 1/4	9 7/8	-
SRUB 220/250	79 1/2	34 3/4	58	17 1/16	16	39 1/16	36 1/4	10	16 1/4	8 7/8	13 3/8

Note: All dimensional data are in inch.

PRODUCT SPECIFICATIONS

EVAPORATOR SECTION

- Convertible horizontal or vertical air discharge.
- Evaporator coil with leak tested.
- Single refrigeration circuit for SRUB 080-130.
- Dual refrigeration circuits for SRUB 160-250.
- Thermal expansion valve(s), factory installed.
- Double inlet, double width, forward curve, centrifugal type evaporator fan(s) with adjustable belt drive.
- Thermal overload protection for evaporator fan motor.
- Completely insulated with fire-retardant, polyethylene foam.
- 1" aluminum cleanable filter.

CONDENSING SECTION

- Single compressor for SRUB 080-130.
- Dual compressors for SRUB 160-250 with 2- step capacity control.
- Filter driers and service valves.
- Factory leak tested at 400 psig air pressure.
- Copper tube, aluminum plate fin coil with integral subcooled circuit.
- Suction gas cooled, temperature and current-sensitive motor overload for compressor motor.
- Double inlet, double width, forward curve, centrifugal type fan(s) with belt drive.
- Build in current and thermal overload protection or condenser fan motors.
- External high and low pressure cut-out devices.
- Completely factory wired with 220 volt control circuit.
- Plus or minus 10 percents of name plate voltage for utilization range.



ทราน (ประเทศไทย)

เลขที่ 1126/2 ชั้น 30-31 อาคารวานิช 2 ถ.เพชรบุรีตัดใหม่ แขวงมักกะสัน เขตราชเทวี กรุงเทพฯ 10400

☎ 0-2761-1111

