



Product Catalog

# Series R™ Helical Rotary Liquid Chillers

Model RTHD, 150~350 Tons (60 Hz),  
150~450 Tons (50 Hz)

Built for Industrial and Commercial  
Applications

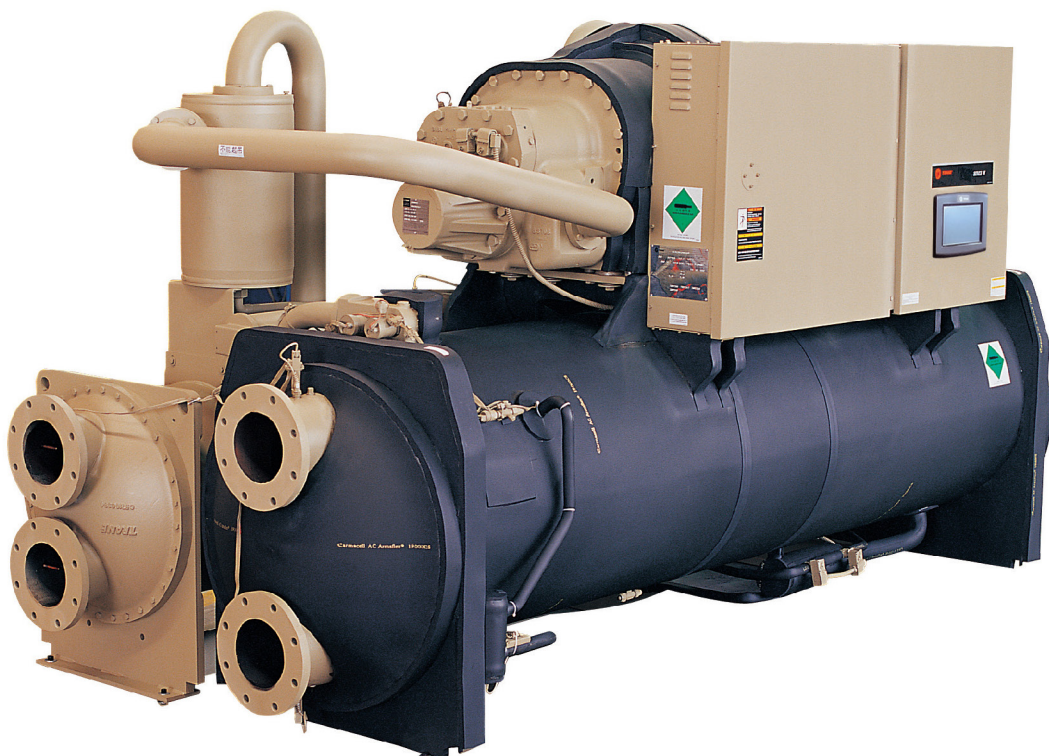



## Introduction

To meet a wide range of applications in the medium-tonnage, water-cooled market, Trane is proud to recommend the model RTHD helical-rotary liquid chiller. This chiller provides application versatility, ease of installation, control precision, reliability, energy efficiency, and operational cost effectiveness.

The RTHD chiller is designed to deliver proven performance, plus all the benefits of an advanced heat transfer design and a low speed, direct-drive compressor

### Important Features

- High full-load energy efficiency reduces both operating and life-cycle costs.
- Tracer™ UC800 controls enable:
  - scrolling access to inputs and operating information via the LCD touch-screen display
  - freedom from interoperability concerns with LonMark® and BACnet® communications
  - job-specific communication options that allow greater reporting flexibility
- Improved start up temperature capabilities and reduced sensitivity to condenser water temperatures all alleviate the most common startup concerns.

The industrial-grade design of the helical-rotary chiller is ideal for both industrial and commercial markets, in applications such as office buildings, hospitals, schools, retail buildings, and industrial facilities. The linear unloading compressor, wide operating temperature range, advanced controls, electronic expansion valve, short anti-recycle timers, and high efficiencies mean that this Trane chiller is the perfect choice for tight temperature control in almost any application temperatures, and under widely varying loads.

# Table of Contents

<b>Introduction</b> .....	<b>2</b>
<b>Features and Benefits</b> .....	<b>4</b>
<b>Controls</b> .....	<b>6</b>
<b>Application Considerations</b> .....	<b>8</b>
<b>Selection Procedure</b> .....	<b>10</b>
<b>Model Nomenclature</b> .....	<b>12</b>
<b>General Data</b> .....	<b>14</b>
<b>Electrical Data and Connections</b> .....	<b>16</b>
<b>Dimensions and Weights</b> .....	<b>19</b>
<b>Mechanical Specifications</b> .....	<b>26</b>
<b>ConversionTable</b> .....	<b>28</b>



# Features and Benefits

## Application Versatility and High Performance

- Screw compressor technology and the electronic expansion valve provide reliable performance in an expanded range of operating temperatures.
- Tight water temperature control extends to operation of multiple chillers in parallel or series configurations, offering further system design flexibility for maximum efficiency.
- Advanced design enables chilled water temperature control to +/- 0.5°F (.28°C) for flow changes up to 10 percent per minute, plus handling of flow changes up to 30 percent per minute for comfort cooling.
- Two-minute stop-to-start and five-minute start-to-start anti-recycle timer allows tight chilled water temperature control in constant or transient low load applications.
- LonMark communications capability provides excellent, trouble-free interoperability.
- Generic Building Automation System points are available for easy access to operational information.
- Extensive information on professional design selection and layout is available in a simple, highly readable electronic format.
- Standard model RTHD configurations are in stock and available for immediate delivery, and Trane offers the fastest ship cycles in the industry for built-to-order units.
- Industrial / Low Temperature Process Cooling – Excellent operating temperature range and precise control capabilities enable tight control with single chiller or series configuration.
- Ice/Thermal Storage – Specifiers and operators benefit from dual setpoint control and industry-leading temperature, efficiency, and control capabilities, plus outstanding support through partnership with Calmac, a strong Trane partner providing proven installation examples, templates, and references that minimize design time and energy costs.

## Simple, Economical Installation

- Compact size makes the model RTHD well suited for the retrofit and replacement market.
- All units fit through standard doublewidth doors.
- Bolt-together construction makes for fast, easy unit disassembly.
- Small RTHD footprint saves valuable equipment room space and alleviates access concerns for most retrofit jobs.
- Lightweight design simplifies rigging requirements, further reducing installation time requirements and costs.
- Full factory refrigerant or nitrogen and oil charges reduce required field labor, materials, and installation cost.
- Only evaporator and condenser water piping is required; no starter water cooling (with its associated safety concerns) or field piping is necessary.
- Oil cooler and purge system connections have been eliminated.
- Simple power connection simplifies overall installation.
- Standard unit-mounted starter for Wye-Delta and Solid State eliminates additional jobsite installation considerations and labor requirements.
- Trane has conducted extensive factory testing, and also offers options for in-person and/or documented system performance verification.
- Tracer AdaptiView™ TD7 control sinter face with Tracer SC, LonTalk®, BACnet® or Modbus™ building automation systems.



## **State-of-the-Art, Precision Control**

- New 7 inch color touch screen display with graphics
- Power by UC800 industry-leading control algorithms
  - Enhanced flow management provides unmatched system performance in variable flow water systems
- Adaptive Control™ keeps the chiller running in extreme conditions
  - Tight set point control
  - Graphical trending
  - Maximized chiller update
- BACnet®, Modbus™, LonTalk® communications capability provides excellent, trouble-free interoperability.
- Generic Building Automation System points are available for easy access to operation information.
- Advanced design enables chilled water temperature control to  $\pm 0.5^{\circ}\text{F}$  ( $.28^{\circ}\text{C}$ ) for flow changes up to 10 percent per minute, plus handling off load changes up to 30 percent per minute for comfort cooling.
- Two-minute top-to-start and five-minute start-to-start anti-recycle time allows tight chilled water temperature control in constant or transient low-load applications.

## **Reliability and Ease of Maintenance**

- Direct drive, low-speed compressor – a simple design with only three moving parts – provides maximum efficiency, high reliability, and low maintenance requirements.
- Electronic expansion valve, with fewer moving parts than alternative valve designs, offers highly reliable operation.
- Suction gas-cooled motor stays uniformly cool at lower temperatures for longer motor life.
- The Trane helical rotary compressor is a proven design resulting from years of research and thousands of test hours, including extensive testing under extraordinarily severe operating conditions.
- Trane is the world's largest manufacturer of large helical rotary compressors, with tens of thousands of commercial and industrial installations worldwide demonstrating a reliability rate of greater than 99 percent in the first year of operation.

## **Operating and Life Cycle Cost-Effectiveness**

- Electronic expansion valve enables exceptionally tight temperature control and extremely low superheat, resulting in more efficient full-load and part-load operation than previously available.
- Precise compressor rotor tip clearance ensures optimal efficiency.
- Condenser and evaporator tubes use the latest heat transfer technology for increased efficiency.
- The RTHD includes optional electrical demand limiting.
- Chilled water reset based on return water temperature is standard.
- High compressor lift capabilities and tight chilled water temperature control allow highly efficient system design with minimal operational concerns.
- Heat recovery option includes partial load and full load heat recovery. For traditional water-cooled chillers, heating capacity is exhausted into air, the heating recovery option allows to recovery partial or total heating capacity for occasion that hot water needed.

## **Design capabilities include:**

- variable primary flow;
- series chiller arrangements for evaporator and/or condenser;
- low evaporator and condenser flow.



# Controls

## Tracer AdaptiView TD7 Operator Interface

The standard Tracer Adaptiview™ TD7 display provided with the Tracer™ UC800 controller features a 7" LCD touch-screen, allowing access to all operational inputs and outputs. This is an advanced interface that allows the user to access any important information concerning setpoints, active temperatures, modes, electrical data, pressure, and diagnostics. It uses full text display available in 26 languages.

### Display Features Include:

- LCD touch-screen with LED backlighting, for scrolling access to input and output operating information
- Single-screen, folder/tab-style display of all available information on individual components (evaporator, condenser, compressor, etc.)
- Manual override indication
- Password entry/lockout system to enable or disable display
- Automatic and immediate stop capabilities for standard or immediate manual shutdown
- Fast, easy access to available chiller data in tabbed format, including:
  - Easy to view Operating Modes
  - Logical Sub-Component Reports:
    - Evaporator
    - Condenser
    - Compressor
    - Motor
  - 3 User Programmable Custom Reports
  - ASHRAE report
  - Logsheets Report
  - Alarms Report
  - 8 pre-defined Standard Graphs
  - 4 User Programmable Custom Graphs
  - Chiller Settings
  - Feature Settings
  - ChilledWater Reset
  - Manual Control Settings
  - Globalization Settings
  - Support of 26 languages
  - Brightness Setting
  - Cleaning Mode

## Tracer SC

The Tracer SC system controller acts as the central coordinator for all individual equipment devices on a Tracer building automation system. The Tracer SC scans all unit controllers to update information and coordinate building control, including building subsystems such as VAV and chiller water systems. With this system option, the full breadth of Trane's HVAC and controls experience are applied to offer solutions to many facility issues. The LAN allows building operators to manage these varied components as one system from any personal computer with web access.

The benefits of this system are:

- Improved usability with automatic data collection, enhanced datalogging, easier to create graphics, simpler navigation, pre-programmed scheduling, reporting, and alarm logs.
- Flexible technology allows for system sizes from 30-120 unit controllers with any combination of LonTalk® or BACnet® unit controllers.
- LEED certification through site commissioning report, energy data collection measurement, optimizing energy performance, and maintaining indoor air quality.
- Energy savings programs include: fan pressure optimization, ventilation reset, and chiller plant control (adds and subtracts chillers to meet cooling loads).

## LonTalk Interface

LonTalk communications capabilities are available, with communication link via single twisted-pair wiring.

Additional options that may be used:

- Ice making and chilled water temperature reset - outdoor air

External devices required:

- LonTalk system compatible interface.

### **LonTalk Chiller Controls**

LonTalk is a communications protocol developed by the Echelon™ Corporation. The LONMARK™ association develops control profiles using the LonTalk communication protocol. LonTalk is a unit level communications protocol.

LonTalk Communications Interface for Chillers (LCI-C) provides a generic automation system with the LONMARK chiller profile inputs/outputs. In addition to the standard points, Trane provides other commonly used network output variables for greater interoperability with any automation system. The complete reference list of Trane LonTalk points is available on the LONMARK web site.

Trane controls or another vendor's system can use the predefined list of points with ease to give the operator a complete picture of how the system is running.

## **BACnet Interface**

BACnet communications capabilities are available, with communication link via single twisted-pair wiring.

Additional options that may be used:

- Ice making and chilled water temperature reset - outdoor air

External devices required:

- BACnet MS/TP network.

### **BACnet Chiller Controls**

BACnet is an open standard communications protocol used by building automation systems. BACnet MS/TP uses RS-485 hardware. This device is a non-programmable communication module that connects directly to the UC800 chiller control.

## **Modbus Interface**

Tracer AdaptiView™ control can be configured for Modbus™ communications at the factory or in the field. This enables the chiller controller to communicate as a slave device on a Modbus network.

Chiller setpoints, operating modes, alarms, and status can be monitored and controlled by a Modbus master device.

## **Hardwire Points**

Remote devices wired from the control panel are another reliable method of providing auxiliary control to a building automation system. Inputs and outputs can be communicated via a typical 4–20 mA electrical signal, an equivalent 2–10 Vdc signal, or by utilizing contact closures.

Selectable options:

- External chilled water setpoint, external current-limit setpoint
- Condenser leaving hotwater temperature control setpoint (available on units with wye-delta starters)
- Ice making control (available on units with wye-delta starters)
- Chilled water temperature reset
- Condenser pressure output
- Motor current analog output
- Programmable relays available outputs are: alarm-latching, alarm-auto reset, general alarm, warning, chiller limit mode, compressor running, head pressure relief request, and Tracer control

# Application Considerations

## Condenser Water Temperatures

Reduced sensitivity to condenser water startup temperatures is one major enhancement in the newest-generation water-cooled Series R chiller. With the model RTHD chiller, a condenser water control method is necessary only if the unit starts with entering water temperatures below 55°F (12.8°C), or between 45°F (7.2°C) and 55°F (12.8°C), when a temperature increase of 1°F (0.56°C) per minute to 55°F (12.8°C) is not possible.

When the application requires startup temperatures below the prescribed minimums, a variety of options are available. To control a 2-way or 3-way valve, Trane offers a Condenser Regulating Valve Control option for the UC800 controls. This option enables the UC800 controls to send a signal for opening and closing the valve as necessary to maintain chiller differential pressure. The 2-way valves are available as a ship-with option. Tower bypass is also a valid control method if the chiller temperature requirements can be maintained.

Trane Series R chillers start and operate successfully and reliably over a range of load conditions with controlled entering condenser water temperature. Reducing the condenser water temperature is an effective method of lowering chiller power input required, but the ideal temperature for optimizing total system power consumption will depend on the overall system dynamics. From a system perspective, some improvements in chiller efficiency may be offset by the increased tower fan and pumping costs required to achieve the lower tower temperatures. Contact your local Trane systems solution provider for more information on optimizing system performance.

The minimum acceptable refrigerant pressure differential between condenser and evaporator is 23 psid. The chiller control system will attempt to obtain and maintain this differential at startup, but for continuous operation a design should maintain a 25°F (13.9°C) differential from evaporator leaving water temperature to condenser leaving water temperature.

## Variable Evaporator Flow and Short Evaporator Water Loops

Variable evaporator flow is an energysaving design strategy which has quickly gained acceptance as advances in chiller and controls technology have made it possible. With its linear unloading compressor design and advanced UC800 controls, the RTHD has excellent capability to maintain leaving water temperature control within  $\pm 0.5^\circ\text{F}$  (0.28°C), even for systems with variable evaporator flow and small chilled water volumes.

Some basic rules should be followed whenever using these system design and operational savings methods with the RTHD. The proper location of the chilled water temperature control sensor is in the supply (outlet) water.

This location allows the building to act as a buffer, and it assures a slowly changing return water temperature. If there is insufficient water volume in the system to provide an adequate buffer, temperature control can be lost, resulting in erratic system operation and excessive compressor cycling. To ensure consistent operation and tight temperature control, the chilled water loop should be at least two minutes. If this recommendation cannot be followed, and tight leaving water temperature control is necessary, a storage tank or larger header pipe should be installed to increase the volume of water in the system.

For variable primary flow applications, the rate of chilled water flow change should not exceed 10 percent of design per minute to maintain  $\pm 0.5^\circ\text{F}$  (0.28°C) leaving evaporator temperature control. For applications in which system energy savings is most important and tight temperature control is classified as  $\pm 2^\circ\text{F}$  (1.1°C), up to 30 percent changes in flow per minute are possible. Flow rates should be maintained between the minimum and maximum allowed for any particular chiller configuration.



## Series Chiller Arrangements

Another energy-saving strategy is to design the system around chillers arranged in series, on the evaporator, condenser, or both. The actual savings possible with such strategies depends on the application dynamics and should be researched by consulting your Trane Systems Solutions Representative and applying the Trane System Analyzer program. It is possible to operate a pair of chillers more efficiently in a series chiller arrangement than in a parallel arrangement. It is also possible to achieve higher entering-to-leaving chiller differentials, which may, in turn, provide the opportunity for lower chilled water design temperature, lower design flow, and resulting installation and operational cost savings. The Trane screw compressor also has excellent capabilities for “lift,” which affords an opportunity for savings on the evaporator and condenser water loops. Like series arrangements on the evaporator, series arrangements on the condenser may enable savings. This approach may allow reductions in pump and tower installation and operating costs. Maximizing system efficiency requires that the designer balance performance considerations for all system components; the best approach may or may not involve multiple chillers, or series arrangement of the evaporators and/or condensers. This ideal balance of design integrity with installation and operating cost considerations can also be obtained by consulting a Trane representative and applying the Trane System Analyzer program.

## Water Treatment

The use of untreated or improperly treated water in chillers may result in scaling, erosion, corrosion, and algae or slime buildup. It is recommended that the services of a qualified water treatment specialist be engaged to determine what treatment, if any, is advisable. Trane assumes no responsibility for the results of using untreated or improperly treated water.

## Water Pumps

Where noise limitation and vibrationfree operation are important, Trane strongly encourages the use of 1750-rpm (60 Hz), 1450-rpm (50 Hz) pumps.

Specifying or using 3600-rpm (60 Hz), 3000-rpm (50 Hz) condenser water and chilled water pumps must be avoided, because such pumps may operate with objectionable levels of noise and vibration. In addition, a low frequency beat may occur due to the slight difference in operating rpm between 3600-rpm (60 Hz), 3000-rpm (50 Hz) water pumps and Series R chiller motors. Important Note: The chilled water pump must not be used to stop the chiller.

## Acoustic Considerations

For chiller sound ratings, installation tips, and considerations on chiller location, pipe isolation, etc., refer to the Trane Water-Cooled Series R Chillers Sound Ratings and Installation Guide.

Using the information provided in this bulletin, contact a certified sound consultant to aid in proper mechanical room design and treatment.





## Selection Procedure

Trane Series R chiller performance is rated in accordance with the ARI Standard 550/590-2003 Certification Program. Chiller selection assistance and performance information can be obtained by using the Series R chiller selection program, available through local Trane sales offices.

### Performance

The computerized Series R chiller selection program provides performance data for each possible chiller selection at both full-load and part-load design points, as required. It should be noted that changing the number of water passes or the water flow rates will generally alter the performance of a particular chiller. To attain maximum benefit from the wide range of chiller models and options available, designers are encouraged to first develop performance specifications and then use the chiller selection program to optimize all selections. This will help ensure selection of the compress or evaporator - condenser combination that most closely meets the job requirements. To optimize system performance, all selections should also be balanced with other system components.

### Fouling Factors

ARI Standard 550 includes a definition of clean tube fouling. The recommended standard fouling adjustments are 0.0001 hr-sq ft-deg F/Btu (0.0176 sq m-deg C/kW) for the evaporator and 0.00025 hr-sq ft deg F/Btu (0.044 sq m-deg C/kW) for the condenser, from an increment of 0.0000 "clean." Chiller specifications should be developed using the most current standard fouling factors.

### Part Load Performance

Actual air-conditioning system loads are frequently less than full-load design conditions. Depending on the number of chillers on the job and the load profile, chillers may operate at full load a small percentage of the time. With their excellent part-load performance characteristics and highly energy efficient operation, Series R chillers can provide significant operating savings at these part-load conditions, maximum down to 20%.

### System Considerations

Part-load chiller operation is frequently associated with reduced condenser water temperatures. However, rather than focusing only on the chiller, it is important to balance these temperatures to achieve the most efficient system operation possible. At part-load operation, the heat rejected to the cooling tower is less than at fullload operation.

Part-load chiller operation is also typically associated with reduced outside wet bulb temperatures, resulting in improved cooling tower performance. The net result of reduced heat rejection and lower wet bulb temperatures can be cooler condenser water entering the chiller, ultimately improving unit performance. However, this does not improve pump or tower efficiency. To achieve the most efficient system operation possible, it is best to minimize the total power draw of the chiller, tower, and pumps, which may not mean limiting the condenser water temperature to what the tower can provide. To determine specific unit and system part-load performance for chiller selection purposes, use the Series R chiller computer selection program or contact the local Trane sales office.

## Unit Performance with Fluid Media Other Than Water

Series R chillers can be provided with a wide variety of fluid media other than water, including ethylene glycol and propylene glycol—in the evaporator, condenser or both. Chillers using media other than water are excluded from the ARI 550/590-2003 Certification Program, but are rated in accordance with ARI Standard 550/590-2003. Trane factory performance tests are only performed with water as the cooling and heat-rejection media. When considering selection of media other than water, contact the local Trane sales office for chiller selections and factory performance testing information.

Fluid media other than water lowers the heat transfer coefficient, and therefore reduces chiller performance.

In general, it is good practice to hold the percent glycol added to within the minimum allowed by the Trane selection program, based on either (a) unit operating temperatures, or (b) the operating temperatures the evaporator or condenser water will experience under its full range of conditions. Adding more glycol than required for the specific application is equivalent to selecting a less efficient chiller. Lower viscosity glycols such as ethylene will have less adverse impact on chiller performance than higher-viscosity glycols such as propylene.

## Evaporator and Condenser Pressure Drop

Pressure drop data is determined by the Series R chiller computer selection program available through local Trane sales offices.

## Dimensional Drawings

Dimensional drawings provided for selection purposes illustrate overall measurements of the unit. The recommended service clearances are those required to easily service the Series R chiller. All catalog dimensional drawings are subject to change, and current submittal drawings should be referenced for more detailed dimensional information. Dimensional drawings are also available from the selection program. Contact the local Trane sales office for submittal information.

## Electrical Data Tables

Compressor motor electrical data is provided in the data section for each compressor size. Rated load amperes (RLA), locked rotor wye amperes (LRA) and expected inrush for the Wye-delta and Solid State Starter configurations are shown.

Although the terms “LRA” and “expected inrush” are often used interchangeably, the distinction applied here is that LRA is the rated inrush for the motor, but expected inrush is that allowed by the starter, based on the specific configuration.

Selecting starters in the Wye-delta or Solid State configuration lowers expected inrush vs. the Delta (or “across-the-line”) configuration. A Solid State Starter configuration lowers the expected inrush by approximately 50 percent, while Wye-Delta lowers it by approximately 66 percent. The RLA is based on the motor’s performance when reaching full rated horsepower. The kW rating of the motor will equal or exceed the kW requirement indicated by the Series R computer selection program at design conditions. If motor kW draw at design conditions is less than the kW rating of the motor, the RLA at design conditions is determined by multiplying the motor RLA (at the desired voltage) by this ratio: design kW/motor kW rating. This calculation is performed within the Series R chiller computer selection program, making RLA available as part of the design predictions. Predicted values include power factor variation from point to point.

A voltage utilization range is tabulated for each voltage listed. Series R chillers are designed to operate satisfactorily over a utilization range of  $\pm 10$  percent of the standard design voltages: 380 V, 415 V for 50 Hertz, 3-phase.



# Model Nomenclature

**R T H D C B 1 R X A 0 X L B 1 A 3 L A L B 1 A 2 L A L A X X**  
 1 2 3 4 5 6 7 8 9 10 11 12 13 14 15 16 17 18 19 20 21 22 23 24 25 26 27 28 29 30

**Digit 1-4 Basic Product Line**  
 RTHD=Water-cooled Series R

**Digit 5 Manufacturing Plant**  
 U=Water Chiller Business Unit, Pueblo CO USA  
 E=Epinal Business Unit, Charmes  
 C=China Business Unit

**Digit 6-7 Compressor**  
 B1=B1 compressor  
 B2=B2 compressor  
 BE=B2 compressor(with auxillary port)  
 C1=C1 compressor  
 C2=C2 compressor  
 CE=C2 compressor(with auxillary port)  
 D1=D1 compressor  
 D2=D2 compressor  
 D3=D3 compressor (50HZ only)  
 E3=E3 compressor (50HZ only)  
 DE=D3 compressor(with auxillary port, 50HZ only)  
 EE=E3 compressor(with auxillary port, 50HZ only)

**Digit 8 Unit Power Supply**  
 C=230V/60Hz/3Ph power  
 D=380V/60Hz/3Phpower  
 R=380V/50Hz/3Phpower  
 T=400V/50Hz/3Phpower  
 U=415V/50Hz/3Ph power  
 F=460V/60Hz/3Phpower

**Digit 9 Design Specials**  
 X=None  
 C=Specials denoted elsewhere  
 S=Specials not denoted elsewhere

**Digit 10-11 Design Sequence**  
 E0=Factory/ABU assigned, start withA0

**Digit 12 Agency Listing**  
 X=No agency listing  
 U=C/UL listing  
 3=CCC-Chinese Compulsory Code

**Digit 13 Pressure Vessel Code**  
 A=ASME pressure vessel code  
 C=Canadian code  
 L=Chinese code

S=Special

**Digit 14-15 Evaporator**

B1=B1 evaporator  
 B2=B2 evaporator  
 C1=C1 evaporator  
 C2=C2 evaporator  
 D1=D1 evaporator  
 D2=D2 evaporator  
 D3=D3 evaporator  
 D4=D4 evaporator  
 D5=D5 evaporator  
 E1=E1 evaporator  
 F1=F1 evaporator  
 F2=F2 evaporator  
 G1=G1 evaporator  
 G2=G2 evaporator  
 G3=G3 evaporator  
 H3=H3 evaporator

**Digit 16 Evap Tube type**

A=Standard  
 B=High efficiency

**Digit 17 Evaporator Passes**

2=2 pass evaporator  
 3=3 pass evaporator  
 4=4 pass evaporator

**Digit 18 Evaporator Water**

Connection  
 L=Left hand evaporator connection  
 R=Right hand evaporator connection

**Digit 19 Evaporator Connection Type**

A=Standard flange connection  
 S=Special

**Digit 20 Evaporator Water Side**

Pressure  
 L=150PSI/10.5Bar evaporator water pressure  
 H=300PSI/21Bar evaporator water pressure

**Digit 21-22 Condenser**

B1=B1 condenser  
 B2=B2 condenser  
 D1=D1 condenser  
 D2=D2 condenser  
 E1=E1 condenser

E2=E2 condenser  
 E3=E3 condenser  
 E4=E4 condenser  
 E5=E5 condenser  
 F1=F1 condenser  
 F2=F2 condenser  
 F3=F3 condenser  
 G1=G1 condenser  
 G3=G3 condenser  
 H1=H1 condenser+heat recovery coil  
 H2=H2 condenser+heat recovery coil  
 J1=J1 condenser+heat recovery coil  
 J2=J2 condenser+heat recovery coil  
 J3=J3 condenser+heat recovery coil  
 K1=K1 condenser+heat recovery coil  
 L1=L1 condenser+heat recovery coil  
 L2=L2 condenser+heat recovery coil  
 M1=M1 condenser+heat recovery coil  
 M2=M2 condenser+heat recovery coil  
 M3=M3 condenser+heat recovery coil  
 N1=N1 condenser+heat recovery coil

**Digit 23 Condenser Tube Type**

A=Enhanced fin-copper  
 B=Smooth bore-copper  
 C=Smooth bore-90/10 Cu/Ni

**Digit 24 Condenser Passes**

2=2 pass

**Digit 25 Condenser Water**

**Connection**  
 L=Left hand evaporator connection  
 R=Right hand evaporator connection

**Digit 26 Condenser Connection Type**

A=Standard flange connection  
 C=Marine  
 S=Special

**Digit 27 Condenser Water Side**

**Pressure**  
 L=150PSI/10.5Bar evaporator water pressure  
 H=300PSI/21Bar evaporator water pressure

**Digit 28 Condenser Leaving Water Temp**

A=Standard (<45 deg C)



**Q X C X A A B X Y 1 7 4 A A X H X X X X X X X X X X X**  
 31 32 33 34 35 36 37 38 39 40 41 42 43 44 45 46 47 48 49 50 51 52 53 54 55 56 57

**Digit 29 Refrigerant Specialties**

X=No refrigerant isolation valves  
 V=Refrigerant isolation valves

**Digit 30 Oil Cooler**

X=without oil cooler  
 C=with oil cooler

**Digit 31 Thermal Insulation**

X=No insulation  
 Q=Factory insulation cold parts  
 S=Thick insulation

**Digit 32 Sound Attenuator**

X=No attenuator  
 A=Standard attenuator

**Digit 33 Control, Label and Literature**
**Language**

E=English  
 C=Chinese

**Digit 34 Safety Devices**

X=Standard

**Digit 35 Shipping Charge**

A=Full factory charge  
 B=Nitrogen  
 C=Refrigerant charged less than 12kg(R134a)

**Digit 36 Shipping Package**

A=Domestic  
 B=Domestic+shrink wrap  
 C=Skid  
 D=Skid+shrink wrap  
 J=Special

**Digit 37 Flow Switch**

X=Without  
 A=Evap NEMA-1  
 B=Evap&Cond NEMA-1  
 C=Evap vapor  
 D= Evap & Cond Vapor  
 E= Evap & Cond & HR Cond NEMA-1

**Digit 38 Factory Performance Test**

X=Without  
 C=Witness test  
 D=Performance test w/report  
 S=Special

**Digit 39 Starter Type**

Y=Wye-delta closed transition starter  
 A=Solid state starter

**Digit 40-42 Design RLA**

Selection RLA

**Digit 43 Power Line Connection Type**

A=Terminal block connection for incoming line  
 B=Mech disconnect switch  
 D=Circuit breaker  
 F=High interrupt circuit breaker  
 H=Ground fault circuit breaker  
 J= Ground fault high interrupt circuit breaker

**Digit 44 Enclosure Type**

A=NEMA1

**Digit 45 Under/over Voltage**
**Protection**

X=No under/over voltage protection  
 U=under/over voltage protection

**Digit 46 Unit Operator Interface**

A=Dyna-view operator interface-Pueblo  
 D=Dyna-view/Spanish  
 G=Dyna-view/Trad.Chinese  
 H=Dyna-view/Simp.Chinese  
 J=Dyna-view/Japanese  
 K=Dyna-view/Portugese(Brazil)  
 L=Dyna-view/Korean  
 M=Dyna-view/Thai

**Digit 47 Remote Interfaces (digital comm)**

X=No remote digital comm  
 4=Tracer comm4 interface  
 5=Tracer comm5 LCI-C (Iontalk)

**Digit 48 External Chilled Water& Current Limit Setpoint**

X=None  
 4=4-20 ma input  
 2=2-10 Vdc input

**Digit 49 External Base Loading**

X=None

4=4-20 ma input  
 2=2-10 Vdc input

**Digit 50 Icemaking**

X=None  
 A=Icemaking with relay  
 B=Icemaking without relay

**Digit 51 Programmable Relays**

X=None  
 R=Programmable relay

**Digit 52 Chilled Water Reset-outdoor air temp**

X=No sensor (return water CHW reset standard)  
 T=Chilled water reset-outdoor air temp

**Digit 53 Reg.Valve&RLA**

X=None  
 V=Condenser reg.valve out &%RLA out  
 P=Condenser pressure (%HPC) &%RLA out  
 D=Chiller Delta P&% RLA out

**Digit 54 Refrigerant Monitor Input**

X=None  
 X=None  
 A=100 ppm/4-20 ma  
 B=1000 ppm/4-20 ma  
 C=100 ppm/2-10 Vdc  
 D=1000 ppm/2-10 Vdc

**Digit 55 Hot Water Control**

X=None  
 H=With hot water control

**Digit 56 Installation Accessories**

X=None  
 A=Elastomeric isolators

**Digit 57 Heat Recovery**

X = None  
 1 = Partial heat recovery  
 2 = Total heat recovery



# General Data

## Nominal Data

Nominal Compressor	B1	B2	BE	C1	C2	CE	D1	D2	D3	E3
Tonnage (60 Hz)	175-200	200-225	N/A	225-275	275-325	N/A	325-400	375-450	N/A	N/A
Tonnage (50 Hz)	125-150	150-175	200	175-225	225-275	300	275-325	300-350	325-375	375-450

### Notes:

1. Chiller selections can be optimized through the use of the AHRI-Certified Series R selection program and by contacting your local Trane sales office.

## General Data

Compressor Code	Evaporator Code	Condenser Code	Evaporator Water Storage		Condenser Water Storage		Refrigerant Type	Refrigerant Charge	
			Gallons	Liters	Gallons	Liters		lb	kg
B1	B1	B1	41	155	28	106	HFC-134a	410	186
B1	C1	D1	55	208	31	117	HFC-134a	490	222
B2	B2	B2	45	170	29	110	HFC-134a	410	186
B2/BE	C2	D2	58	220	34	129	HFC-134a	490	222
C1	C2	D2	58	220	34	129	HFC-134a	490	222
C1	D3	E3	78	295	47	178	HFC-134a	490	222
C1	D6	E5	45	170	29	110	HFC-134a	490	222
C1	D5	E4	52	197	32	121	HFC-134a	490	222
C1	E1	F1	82	310	60	226	HFC-134a	525	238
C2	D4	E4	52	197	32	121	HFC-134a	490	222
C2	D3	E3	78	295	47	178	HFC-134a	490	222
C2	E1	F1	82	310	60	226	HFC-134a	525	238
C2/CE	F2	F3	107	405	61	231	HFC-134a	624	283
D1	D1	E1	69	261	44	166	HFC-134a	474	215
D1	F1	F2	102	386	57	216	HFC-134a	624	283
D1	G1	G1	136	515	79	299	HFC-134a	701	318
D2	D2	E2	74	280	47	178	HFC-134a	474	215
D2	F2	F3	107	405	61	231	HFC-134a	624	283
D2	G2	G1	144	545	79	299	HFC-134a	701	318
D3/E3	D2	E2	74	280	47	178	HFC-134a	474	215
D3/E3	F2	F3	107	405	61	231	HFC-134a	624	283
D3/E3	G2	G1	144	545	79	299	HFC-134a	701	318
D3/E3	G3	G3	157	596	118	446	HFC-134a	701	318
B1	C1	H1	55	208	62	234	HFC-134a	565	257
B2	C2	H2	58	220	68	258	HFC-134a	565	257
C1	E1	J1	82	310	120	452	HFC-134a	645	293
C2	F2	J3	107	405	122	462	HFC-134a	745	339
D1	F1	J2	102	386	114	432	HFC-134a	744	338
D2	G2	K1	144	545	158	598	HFC-134a	788	358
D3/E3	G2	K1	144	545	158	598	HFC-134a	788	358
B1	C1	L1	55	208	42	158	HFC-134a	565	257
B2	C2	L2	58	220	46	174	HFC-134a	565	257
C1	E1	M1	82	310	81	305	HFC-134a	645	293
C2	F2	M3	107	405	82	312	HFC-134a	745	339
D1	F1	M2	102	386	77	292	HFC-134a	744	338
D2	G2	N1	144	545	107	404	HFC-134a	788	358
D3/E3	G2	N1	144	545	107	404	HFC-134a	788	358
DE	H3	G3	171	646	118	446	HFC-134a	701	318
EE	H3	G3	171	646	118	446	HFC-134a	882	400



**Minimum/Maximum Evaporator Flow Rates (Gallons/Minute )**

Evaporator Code	Two Pass			Three Pass			Four Pass		
	Min (gpm)	Max (gpm)	Nominal Conn Size (in.)	Min (gpm)	Max (gpm)	Nominal Conn Size (in.)	Min (gpm)	Max (gpm)	Nominal Conn Size (in.)
B1	253	1104	8	168	736	6	-	-	-
B2	288	1266	8	192	844	6	-	-	-
C1	320	1412	8	213	941	6	-	-	-
C2	347	1531	8	232	1022	6	-	-	-
D1	415	1812	8	275	1205	8	208	906	6
D2	450	1980	8	300	1320	8	225	990	6
D3	486	2131	8	324	1417	8	242	1065	6
D4	351	1542	8	234	1028	8	176	771	6
D5	351	1542	8	234	1028	8	176	771	6
D6	293	1287	8	196	860	8	147	644	6
E1	450	1980	8	300	1320	8	225	989	6
F1	563	2478	10	376	1655	8	-	-	-
F2	604	2667	10	404	1780	8	-	-	-
G1	-	-	-	505	2218	8	379	1666	8
G2	-	-	-	550	2413	8	411	1807	8
G3	-	-	-	621	2732	8	466	2050	8
H3	-	-	-	596	2618	8	447	1963	8

**Notes:**

1. Minimum flow rates are based on water only. 2. All water connections are flange connections.

**Minimum/Maximum Evaporator Flow Rates (Liters/Second)**

Evaporator Code	Two Pass			Three Pass			Four Pass		
	Min (l/s)	Max (l/s)	Nominal Conn Size (mm)	Min (l/s)	Max (l/s)	Nominal Conn Size (mm)	Min (l/s)	Max (l/s)	Nominal Conn Size (mm)
B1	16	70	200	11	46	150	-	-	-
B2	18	80	200	12	53	150	-	-	-
C1	20	89	200	13	59	150	-	-	-
C2	22	97	200	15	65	150	-	-	-
D1	26	114	200	17	76	200	14	57	150
D2	28	125	200	19	83	200	15	62	150
D3	31	134	200	20	89	200	15	67	150
D4	22	97	200	15	65	200	12	48	150
D5	22	97	200	15	65	200	12	48	150
D6	18	81	200	12	54	200	10	40	150
E1	28	125	200	19	83	200	14	62	150
F1	36	156	250	24	104	200	-	-	-
F2	38	168	250	25	112	200	-	-	-
G1	-	-	-	32	140	200	24	105	200
G2	-	-	-	36	152	200	26	114	200
G3	-	-	-	39	172	200	29	129	200
H3	-	-	-	38	167	200	28	124	200

**Notes:**

1. Minimum flow rates are based on water only. 2. All water connections are flange connections.

**Minimum/Maximum Condenser Flow Rates (Gallons/Minute)**

Condenser Code	Two Pass		
	Min (gpm)	Max (gpm)	Nominal Conn Size (in.)
B1	193	850	6
B2	212	935	6
D1	193	850	6
D2	212	935	6
E1	291	1280	8
E2	316	1390	8
E3	325	1420	8
E4	245	1080	8
E5	206	910	8
F1	375	1650	8
F2	355	1560	8
F3	385	1700	8
G1	444	1960	8
G2	535	2360	8
G3	589	2599	8

**Notes:**

1. Minimum flow rates are based on water only.  
2. All water connections are flange connections.

**Minimum/Maximum Condenser Flow Rates (Liters/Second)**

Condenser Code	Two Pass		
	Min (l/s)	Max (l/s)	Nominal Conn Size (mm)
B1	12	54	150
B2	13	59	150
D1	12	54	150
D2	13	59	150
E1	18	81	200
E2	20	88	200
E3	21	90	200
E4	15	68	200
E5	13	57	200
F1	24	104	200
F2	22	98	200
F3	24	107	200
G1	28	124	200
G2	34	149	200
G3	37	164	200

**Notes:**

1. Minimum flow rates are based on water only.  
2. All water connections are flange connections.



## General Data

### Minimum/maximum condenser and total heat recovery coil flow rates

Condenser Code	Min (gpm)	Max (gpm)	Nominal Conn Size (in.)
H1	190	856	6
H2	206	935	6
J1	380	1649	8
J3	349	1696	8
J2	349	1554	8
K1	444	1966	8
K1	444	1966	8
K1	444	1966	8

Condenser Code	Min (l/s)	Max (l/s)	Nominal Conn Size (mm)
H1	12	54	150
H2	13	59	150
J1	24	104	200
J3	22	107	200
J2	22	98	200
K1	28	124	200
K1	28	124	200
K1	28	124	200

### Minimum/maximum condenser coil flow rates (partial heat recovery model)

Condenser Code	Min (gpm)	Max (gpm)	Nominal Conn Size (in.)
L1	190	856	6
L2	206	935	6
M1	380	1649	8
M3	349	1696	8
M2	349	1554	8
N1	444	1966	8
N1	444	1966	8
N1	444	1966	8

Condenser Code	Min (l/s)	Max (l/s)	Nominal Conn Size (mm)
L1	12	54	150
L2	13	59	150
M1	24	104	200
M3	22	107	200
M2	22	98	200
N1	28	124	200
N1	28	124	200
N1	28	124	200

### Minimum/maximum heat recovery coil flow rates (partial heat recovery model)

Condenser Code	Min (gpm)	Max (gpm)	Nominal Conn Size (in.)
L1	79	304	3
L2	72	304	3
M1	133	476	4
M3	123	491	4
M2	124	476	4
N1	158	491	4
N1	158	491	4
N1	158	491	4

Condenser Code	Min (l/s)	Max (l/s)	Nominal Conn Size (mm)
L1	5	19	76
L2	5	19	76
M1	8	30	102
M3	8	31	102
M2	8	30	102
N1	10	31	102
N1	10	31	102
N1	10	31	102

# Electrical Data and Connections

## Compressor Motor Electrical Data (60 Hertz)

Compressor Code	Nominal Voltage	200	230	380	460	575
		Voltage	180/	208/	342/	414/
	Utilization Range	220	254	418	506	633
B1, B2	Max kW	174	174	174	174	174
	RLA @ Max kW	557	484	291	241	798
	LRAY	970	818	488	400	329
	LRAD	3103	2617	1561	1280	1053
C1, C2	Max kW	249	249	249	249	249
	RLA @ Max kW	812	698	421	349	279
	LRAY	1173	936	558	469	375
	LRAD	3634	2901	1727	1453	1162
D1, D2	Max kW	329	329	329	329	329
	RLA @ Max kW	888	888	549	455	367
	LRAY	1690	1532	850	730	612
	LRAD	5477	4966	2755	2366	1984

**Notes:**

1. See Selection Procedure Section for details.
2. The RLA @ Max kW is based on the performance of the motor developing full rated horsepower.
3. Electrical component sizing should be based on actual jobsite operating conditions. This factor can be obtained through the use of the Series R chiller selection program available through local Trane sales offices.

## Compressor Motor Electrical Data (50 Hertz)

Compressor Code	Nominal Voltage	380	400	415
		Voltage	342/	374/
	Utilization Range	418	457	457
B1, B2, BE	Max kW	139	148	148
	RLA @ Max kW	233	233	233
	LRAY	391	428	428
	LRAD	1229	1348	1348
C1, C2, CE	Max kW	201	213	216
	RLA @ Max kW	349	349	349
	LRAY	456	498	498
	LRAD	1414	1544	1544
D1, D2, D3, DE	Max kW	271	284	284
	RLA @ Max kW	455	455	455
	LRAY	711	776	776
	LRAD	2303	2515	2515
E3, EE	Max kW	288	306	306
	RLA @ Max kW	488	488	488
	LRAY	711	776	776
	LRAD	2303	2515	2515

**Notes:**

1. See Selection Procedure Section for details.
2. The RLA @ Max kW is based on the performance of the motor developing full rated horsepower.
3. Electrical component sizing should be based on actual jobsite operating conditions. This factor can be obtained through the use of the Series R chiller selection program available through local Trane sales offices.

## Electrical Connections

Starter Panel Connection	Selection RLA	Lug Size L1-L3 (Each Phase)
Terminals	Only 000-760	(2) #4-500 MCM
	761-888	(4) #4/0-500 MCM
Main Circuit Breaker or Non-Fused Disconnect Switch	000-185	(1) #4-350 MCM
	186-296	(2) 2/0-250 MCM
	297-444	(2) 3/0-350 MCM
	445-592	(2) #1-500 MCM
	593-888	(4) 4/0-500 MCM

**Notes:**

1. Lug sizes are independent of starter type.

# Electrical Data and Connections

## Standard model and partial heat recovery model

**NOTES:**

1. DASHED LINES INDICATE FIELD WIRING BY OTHERS. PHANTOM LINES INDICATE ALTERNATE CIRCUITRY OR AVAILABLE SALES OPTIONS. CHECK SALES ORDER TO DETERMINE IF WIRING IS REQUIRED FOR SPECIFIC OPTIONS.

- 2 REQUIRED DEVICE AND/OR CIRCUITRY BY OTHERS.
- 3 REQUIRED DEVICE AVAILABLE FROM TRANE, FIELD INSTALLED
- 4 OPENING THE EXTERNAL AUTO-STOP CONTACT WILL INITIATE A SHUT DOWN SEQUENCE OF THE CHILLER. CLOSURE OF THE CONTACT WILL ALLOW THE CHILLER TO RETURN TO NORMAL AUTOMATIC OPERATION.
- 5 AN OPENING OF THE EMERGENCY STOP CONTACT WILL SHUT THE CHILLER DOWN IMMEDIATELY AND TRIGGER AN EMERGENCY STOP INPUT DIAGNOSTIC. CLOSURE OF THE CONTACT AND A MANUAL RESET OF THE UNIT CONTROL DIAGNOSTIC WILL ALLOW THE CHILLER TO RETURN TO NORMAL OPERATION.

**GENERAL WIRING REQUIREMENTS AND PROVISIONS**

- 6 THE EIGHT 1/2" CONDUIT KNOCKOUTS LOCATED NEAR THE TOP OF THE RIGHT HAND SIDE OF THE CONTROL PANEL ARE FOR USE WITH LOW VOLTAGE 30 VOLT CIRCUIT WIRING.
- 7 THE SIX 1/2" CONDUIT KNOCKOUTS AND 4 1-1/4" KNOCKOUTS LOCATED NEAR THE BOTTOM OF THE RIGHT HAND SIDE OF THE CONTROL PANEL ARE FOR USE WITH 115 VOLT CIRCUIT WIRING.

**REQUIRED WIRING:**

- 8 CLASS 1 WIRING, 14 AWG, 800 VOLT CONDUCTORS, 115 VOLT CIRCUIT
- 9 CLASS 2 WIRING.

10 TRANE TRACER SUMMIT RECOMMENDED WIRE:  
 TRANE ICS SHIELDED TWISTED PAIR COMMUNICATION CABLE 14-18 AWG, 600V CABLE, 30 VOLT CIRCUIT. THE SUM TOTAL LENGTH OF ALL INTERCONNECTED CABLE SEGMENTS NOT TO EXCEED 5000 FEET. GROUND THE SHIELD AT THE TRACER END ONLY. REFER TO THE IOM FOR COMPLETE CABLE AND INSTALLATION REQUIREMENTS. TRANE TRACER SUMMIT MAY ALSO USE LCI WIRING RECOMMENDED BELOW.

LONTALK COMMUNICATION INTERFACE (LCI) RECOMMENDED WIRE:  
 22 AWG LEVEL 4 UNSHIELDED COMMUNICATION WIRE RECOMMENDED. THE SUM TOTAL LENGTH OF ALL INTERCONNECTED CABLE SEGMENTS NOT TO EXCEED 4800 FEET. CONNECTION TOPOLOGY SHOULD BE DAISSY CHAIN. REFER TO BUILDING AUTOMATION SYSTEM (BAS) COMMUNICATION INSTALLATION LITERATURE FOR END OF LINE TERMINATION RESISTOR REQUIREMENTS.

11 THE FIELD WIRING FOR THE 115V HOT LEG IS TERMINATED TO 1X6 TERMINAL BLOCK. SEE INSTRUCTION LABEL IN CONTROL PANEL FOR WIRE INSERTION INSTRUCTIONS. SPLICE FIELD WIRES TOGETHER AND WIRE TO 1X6.

**GENERAL NOTES:**

- 12. CAUTION-DO NOT ENERGIZE THE UNIT UNTIL CHECK OUT AND STARTUP PROCEDURES HAVE BEEN COMPLETED.
- 13. COMPRESSOR MOTOR IS PROTECTED FROM PRIMARY SINGLE PHASE FAILURE.
- 14. THESE FEATURES ARE OPTIONAL AND MAY OR MAY NOT BE PROVIDED. CUSTOMER PROVIDED WIRING FOR ALL STANDARD FEATURES AND OPTIONS IS SHOWN ON THIS DIAGRAM. OPTIONAL FEATURES ARE SO NOTED.

**WIRING REQUIREMENTS**

- 16. ALL FIELD WIRING MUST BE IN ACCORDANCE WITH THE NATIONAL ELECTRIC CODE AND STATE AND LOCAL REQUIREMENTS. EXPORT UNIT WIRING MUST COMPLY WITH LOCAL APPLICABLE CODES.
- 16. ALL UNIT POWER WIRING MUST BE COPPER CONDUCTORS ONLY AND HAVE A MINIMUM TEMPERATURE INSULATION RATING OF 75 DEGREE C. SEE UNIT NAMEPLATE FOR MINIMUM CIRCUIT AMPACITY AND MAXIMUM FUSE SIZE REQUIREMENTS. USE 800 VOLT COPPER CONDUCTORS ONLY, 200 TO 600 VOLT CIRCUIT, PROVIDE AN EQUIPMENT GROUND IN ACCORDANCE WITH APPLICABLE ELECTRIC CODES.
- 17. LINE VOLTAGE OPTIONS:  
 UNIT MOUNTED TERMINAL BLOCK, DISCONNECT OR HACR CIRCUIT BREAKER  
 THE POWER WIRING LUG SIZE PROVIDED ON THE VARIOUS UNITS IS SHOWN IN TABLE 2.
- 18. ALL CUSTOMER CONTROL CIRCUIT WIRING MUST BE COPPER CONDUCTORS ONLY AND HAVE A MINIMUM INSULATION RATING OF 300 VOLTS. EXCEPT AS NOTED ALL CUSTOMER WIRING CONNECTIONS ARE MADE TO CIRCUIT BOARD MOUNTED BOX LUGS WITH A WIRE RANGE OF 14 TO 18 AWG.

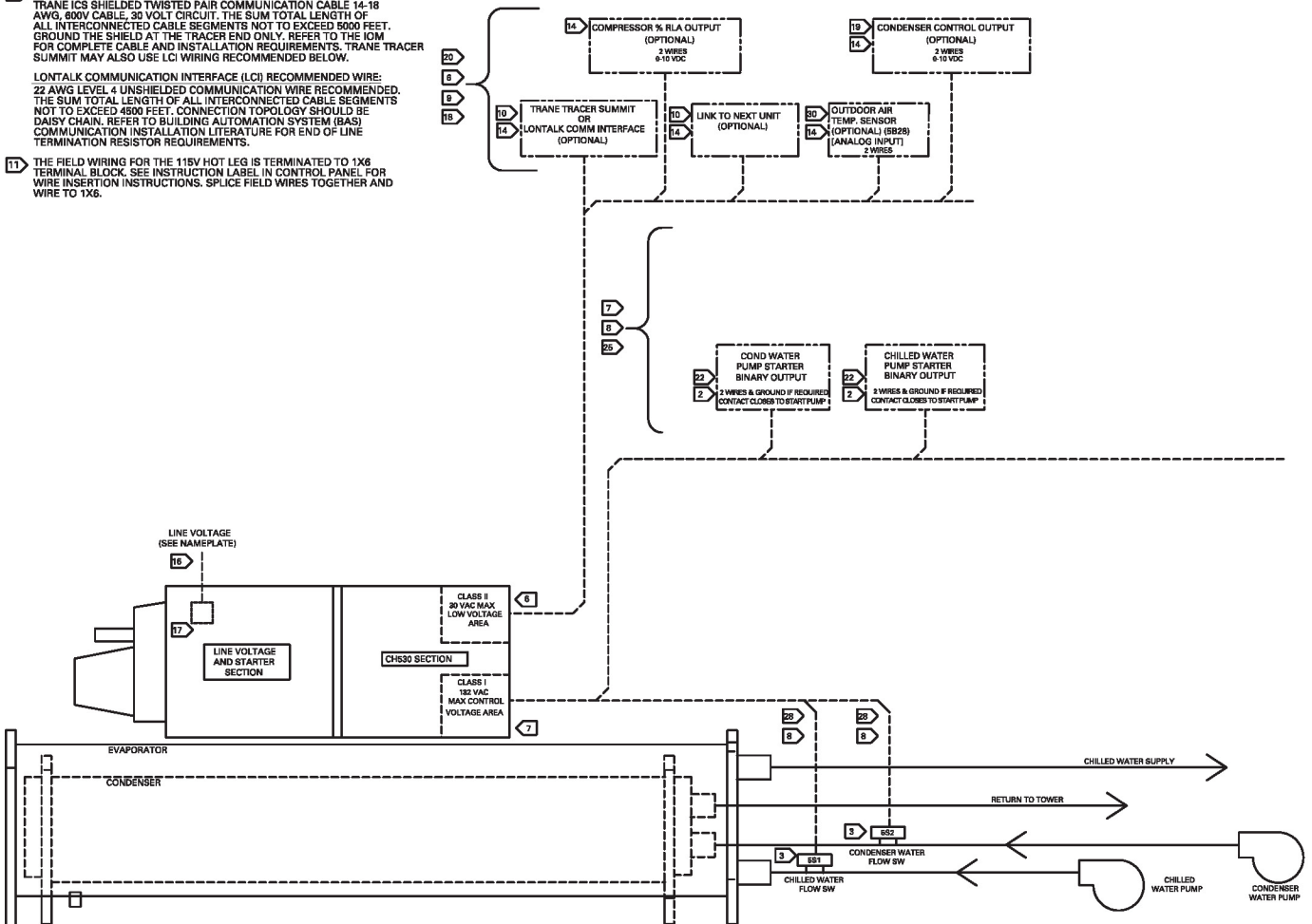

- 18 FIELD SELECTABLE AS: CONDENSER PRESSURE, DELTA PRESSURE OR CONTROL OUTPUT SIGNAL FOR CONDENSER HEAD PRESSURE CONTROL.
  - 20 DO NOT RUN LOW VOLTAGE CONTROL WIRING (30 VOLTS OR LESS) IN CONDUIT WITH 110 VOLT OR HIGHER WIRING. DO NOT EXCEED THE FOLLOWING MAXIMUM RUN LENGTHS FOR A GIVEN SIZE: 14 AWG, 5000 FT; 16 AWG, 2000 FT; 18 AWG, 1000FT.
  - 21 THE CONTACTS FOR THESE FEATURES ARE JUMPERED AT THE FACTORY BY JUMPERS W1 & W2 TO ENABLE UNIT OPERATION. IF REMOTE CONTROL IS DESIRED REMOVE THE NOTED JUMPERS AND CONNECT TO THE DESIRED CONTROL CIRCUIT.
  - 22 FIELD PROVIDED 115 VOLT 60HZ OR 220 VOLT 50HZ CONTROL POWER SUPPLIES ARE REQUIRED. THE MAX FUSE SIZE FOR ALL FIELD PROVIDED WIRING IS 15 AMPS. GROUND ALL CUSTOMER PROVIDED POWER SUPPLIES AS REQUIRED BY CODE. GREEN GROUND SCREWS ARE PROVIDED IN UNIT CONTROL PANEL.
  - 23 CLOSED CONTACT COMMANDS BASE LOADING OPERATION.
  - 24 ACTUAL BASE LOADING SETPOINT USED IS SETABLE AT FRONT PANEL. REFER TO IOM FOR DETAILS.
- CONTACT RATINGS AND REQUIREMENTS**
- 25 UNIT PROVIDED DRY CONTACTS FOR THE CONDENSER/CHILLED WATER PUMP CONTROL. THE UNIT OPERATING STATUS RELAYS AND ICE MAKING STATUS RELAY ARE RATED FOR 7.2 AMPS RESISTIVE, 2.88 AMPS PILOT DUTY, OR 1/2 HP, 7.2 FLA AT 120 VOLTS 60 HZ. CONTACTS ARE RATED FOR 5 AMPS GENERAL PURPOSE DUTY AT 240 VOLTS.
  - 26 CUSTOMER SUPPLIED CONTACTS FOR ALL CLASS 2 CONNECTIONS MUST BE COMPATIBLE WITH DRY CIRCUIT 24 VOLTS DC FOR A 12 MA RESISTIVE LOAD. SILVER OR GOLD PLATED CONTACTS ARE RECOMMENDED.
  - 27 FLOW SWITCH & INTERLOCK CONTACTS MUST BE ACCEPTABLE FOR USE IN A 120 VOLT 1 mA CIRCUIT OR A 220 VOLT 2 mA CIRCUIT.
  - 28 CHILLED / CONDENSER WATER PUMP STARTER AUXILIARY CONTACTS TO BE WIRED IN SERIES WITH FLOW SWITCHES.

- 29 THE FIELD PROVIDED INDICATORS MAY BE RELAYS, LIGHTS OR AUDIBLE DEVICES. EACH FUNCTION IS ASSOCIATED WITH A SPDT RELAY. THE INDICATORS MAY BE CONNECTED TO EITHER OR BOTH OF THE NORMALLY OPEN OR NORMALLY CLOSED RELAY CONTACTS OF EACH OF THE 4 SPDT RELAYS ON THE OPTIONAL UNIT OPERATING STATUS MODULE. THE FUNCTIONS OF THE OPERATING STATUS MODULE RELAYS ARE PROGRAMMABLE. SEE IOM FOR DETAILS. DEFAULT FUNCTIONS ARE SHOWN. THE NORMALLY OPEN CONTACTS ON EACH RELAY OPERATE AS FOLLOWS:
  - COMPRESSOR RUNNING — THE NO CONTACTS CLOSE WHEN COMPRESSOR STATUS FROM STARTER MODULE IS EITHER STARTING OR RUNNING.
  - ALARM RELAY — THE NO CONTACTS CLOSE WHEN THERE IS AN DIAGNOSTIC THAT HAS CAUSED A CHILLER SHUTDOWN WITH EITHER A MANUAL RESET REQUIRED OR AN AUTOMATIC RESET POTENTIAL.
  - CHILLER LIMIT MODE RELAY — THE NO CONTACTS CLOSE WHENEVER THE CHILLER HAS BEEN RUNNING IN ONE OF THE FOLLOWING MODES (CONDENSER, EVAPORATOR, CURRENT LIMIT OR PHASE IMBALANCE LIMIT) CONTINUOUSLY FOR THE LAST 20 MINUTES.
  - HEAD PRESSURE RELIEF REQUEST — THE NO CONTACTS CLOSE ANYTIME THE CHILLER IS RUNNING IN ONE OF THE FOLLOWING MODES: ICE MAKING MODE OR CONDENSER PRESSURE LIMIT CONTROL MODE CONTINUOUSLY FOR THE DURATION SPECIFIED BY THE CHILLER HEAD RELIEF RELAY FILTER TIME.
- 30 WHEN ORDERED THE OUTDOOR AIR TEMP SENSOR ELECTRONICS IS FACTORY MOUNTED INSIDE THE CONTROL PANEL AND THE IPC BUS IS FACTORY WIRED. THE SENSOR IS TO BE FIELD WIRED, RELOCATED EXTERNALLY WITH THE SENSOR LEADS EXTENDED BACK TO THE CONTROL PANEL. THESE WIRES CAN BE SPLICED WITH TWO 14 - 18 AWG 800V WIRES, WITH A MAXIMUM LENGTH OF 1000 FT (305 METERS). SPLICE AT SENSOR END MUST BE WATER TIGHT. REFER TO UNIT IOM FOR DETAILS.

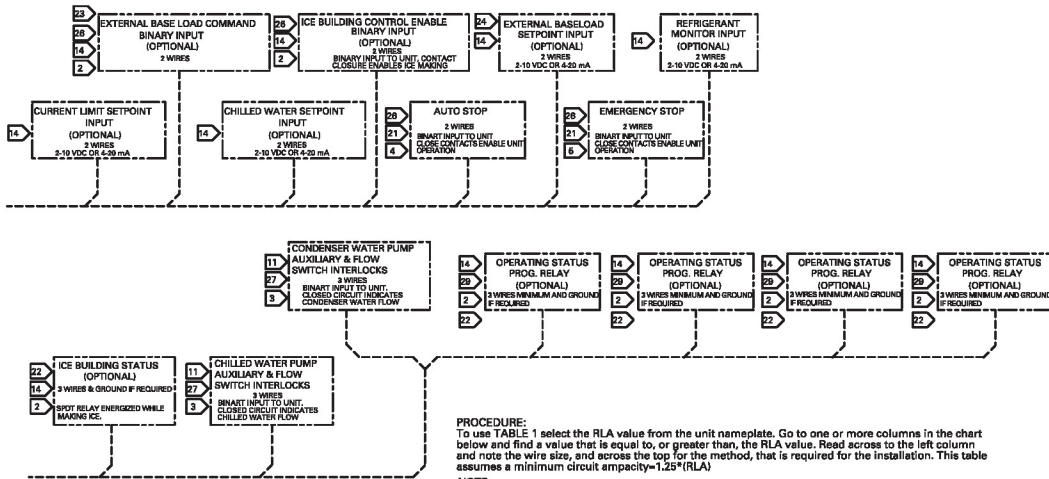

**PROCEDURE:**  
To use TABLE 1 select the RLA value from the unit nameplate. Go to one or more columns in the chart below and find a value that is equal to, or greater than, the RLA value. Read across to the left column and note the wire size, and across the top for the method, that is required for the installation. This table assumes a minimum circuit ampacity=1.25\*(RLA)

**NOTE:**  
This procedure will offer several options for providing electrical service to the starter panel. Before making a final selection, review the accompanying TABLE 2 indicating wire ranges for the available lug sizes supplied on the equipment.

SELECTION RLA	CIRCUIT BREAKER	NON FUSED DISCONNECT SWITCH
0-185	(2) 2/0-250 MCM or (1) 2/0-500 MCM	(1) #4-350 MCM
186-298	(2) 2/0-250 MCM or 2/0-500 MCM	
297-444	(2) 3/0-350 MCM	
445-592	(2) #1-500 MCM	
593-888	(4) 4/0-500 MCM	
	MAIN LUGS ONLY	
000-623	(2)#4-500 MCM	

MIN WIRE SIZE COPPER 75 °C	SUPPLY LEADS FOR ALL STARTER PANELS							
	1 CONDUIT 3 WIRE		1 CONDUIT 6 WIRE		2 CONDUIT 9 WIRE		2 CONDUIT 12 WIRE	
	1 wire/ph/co	2 wire/ph/co	1 wire/ph/co	2 wire/ph/co	1 wire/ph/co	2 wire/ph/co	1 wire/ph/co	2 wire/ph/co
8	40	**	**	**	**	**	**	**
6	52	**	**	**	**	**	**	**
4	68	**	**	**	**	**	**	**
3	80	**	**	**	**	**	**	**
2	92	**	**	**	**	**	**	**
1	104	**	**	**	**	**	**	**
0	120	192	252	240	364	360	480	560
00	140	224	294	280	448	420	560	650
000	160	256	336	320	512	480	640	740
0000	184	294	386	368	588	552	736	840
250	204	328	428	408	652	612	816	912
300	228	368	478	456	730	684	912	1012
350	248	397	521	496	794	744	992	1112
400	268	429	563	536	858	804	1072	1212
500	304	496	636	608	972	912	1212	1412

**WARNING**  
HAZARDOUS VOLTAGE!  
DISCONNECT ALL ELECTRIC POWER INCLUDING REMOTE DISCONNECTS BEFORE SERVICING.  
FAILURE TO DISCONNECT POWER BEFORE SERVICING CAN CAUSE SEVERE PERSONAL INJURY OR DEATH.

**CAUTION**  
USE COPPER CONDUCTORS ONLY!  
UNIT TERMINALS ARE NOT DESIGNED TO ACCEPT OTHER TYPES OF CONDUCTORS.  
FAILURE TO DO SO MAY CAUSE DAMAGE TO THE EQUIPMENT.

\*\* Electrical conductors may be connected in parallel only for size 1/0 wire and larger per Nec 310-4.  
The unit nameplate will be marked 'Maximum Fuse or Circuit Breaker Size'  
The maximum fuse or circuit breaker size is calculated as follows:  
Calculated value = 2.25 \* (Compressor RLA)  
The calculated value is then used to select the fuse or circuit breaker from the standard sizes.  
Standard Sizes = 100, 110, 125, 150, 175, 200, 225, 300, 350, 400, 450, 500, 600, 700, 800, 1000, 1200, 1800, 2000.  
Maximum Fuse or Circuit Breaker Size = The standard size that is closest to the calculated value without exceeding it.



## Total heat recovery model

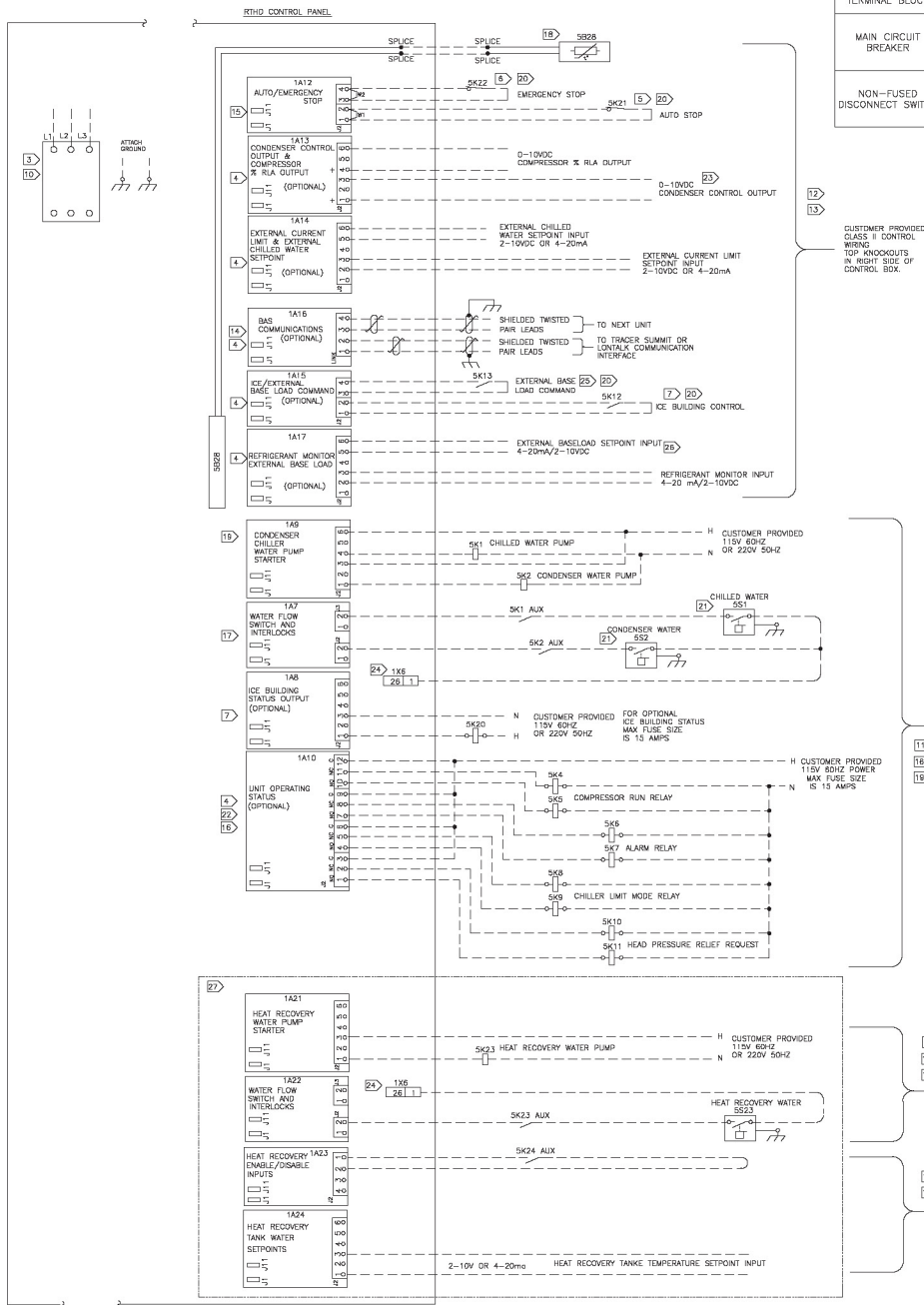

POWER CONNECTION	SELECTION RLA	LUG SIZE (PER PHASE)
TERMINAL BLOCK	0 - 598	(2) #4 - 500 MCM
MAIN CIRCUIT BREAKER	599 - 779	NA
	0 - 200	(1) 3/0 - 350 MCM
	201 - 476	(2) 2/0 - 500 MCM
	477 - 640	(3) 3/0 - 500 MCM
NON-FUSED DISCONNECT SWITCH	641 - 779	(4) 3/0 - 500 MCM
	0 - 277	(1) #1 - 600 MCM
	278 - 397	(2) 2/0 - 500 MCM
	398 - 598	(3) 3/0 - 500 MCM
	599 - 779	(4) 3/0 - 500 MCM

**WARNING**  
HAZARDOUS VOLTAGE!  
DISCONNECT ALL ELECTRIC POWER INCLUDING REMOVE DISCONNECTS AND FOLLOW LOCK OUT AND TAG PROCEDURES BEFORE SERVICING. INSURE THAT ALL MOTOR CAPACITORS HAVE DISCHARGED STORED VOLTAGE. UNITS WITH VARIABLE SPEED DRIVE WATER PUMP DRIVE INSTRUCTIONS FOR CAPACITOR DISCHARGE. FAILURE TO DO THE ABOVE BEFORE SERVICING COULD RESULT IN DEATH OR SERIOUS INJURY.

**AVERTISSEMENT**  
TENSION DANGEREUSE!  
COUPER TOUTES LES TENSIONS ET SUIVRE LES PROCEDURES DE VERROUILLAGE ET DES ETIQUETTES AVANT TOUTE INTERVENTION. VERIFIER QUE TOUTS LES CONDENSATEURS DES MOTEURS SONT DECHARGES. DANS LE CAS D'UNITE COMPORTANT DES ENTRAINEMENT A VITESSE VARIABLE, SE REPORTER AUX INSTRUCTIONS DE L'ENTRAINEMENT POUR DECHARGER LES CONDENSATEURS. NE PAS RESPECTER CES MESURES DE PRECAUTION PEUT ENTRAINER DES BLESSURES GRAVES POUVANT ETRE MORTELLES.

**ADVERTENCIA**  
VOLTAJE PELIGROSO!  
DESCONECTE TODA LA ENERGIA ELECTRICA, INCLUIDAS LAS DESCONEXIONES REMOVIAS, Y SIGA LOS PROCEDIMIENTOS DE BLOQUEO Y ETIQUETADO ANTES DE PROCEDER AL SERVICIO. ASEGURESE DE QUE TODOS LOS CAPACITORES DEL MOTOR HAYAN DESECHARGADO EL VOLTAJE ALMACENADO. PARA LAS UNIDADES CON ELIE DE DIRECCION DE VELOCIDAD VARIABLE, CONSULTE LAS INSTRUCCIONES PARA LA DESCARGA DEL CONDENSADOR. SI NO REALIZA LO ANTERIORMENTE INDICADO, PODRIA OCASIONAR LA MUERTE O SERIAS LESIONES PERSONALES.

**CAUTION**  
USE COPPER CONDUCTORS ONLY!  
UNIT TERMINALS ARE NOT DESIGNED TO ACCEPT OTHER TYPES OF CONDUCTORS. FAILURE TO DO SO MAY CAUSE DAMAGE TO THE EQUIPMENT.

**ATTENTION**  
N'UTILISER QUE DES CONDUCTEURS EN CUIVRE!  
LES BORNES DE L'UNITE NE SONT PAS CONÇUES POUR RECEVOIR D'AUTRES TYPES DE CONDUCTEURS. L'UTILISATION DE TOUT AUTRE CONDUCTEUR PEUT ENDOMMAGER L'EQUIPEMENT.

**PRECAUCION**  
¡UTILICE ÚNICAMENTE CONDUCTORES DE COBRE!  
LAS TERMINALES DE LA UNIDAD NO ESTÁN DISEÑADAS PARA ACEPTAR OTROS TIPOS DE CONDUCTORES. SI NO LO HACE, PUEDE OCASIONAR DAÑO AL EQUIPO.

- GENERAL NOTES:**
- CAUTION-DO NOT ENERGIZE THE UNIT UNTIL CHECK OUT AND STARTUP PROCEDURES HAVE BEEN COMPLETED.
  - COMPRESSOR MOTOR IS PROTECTED FROM PRIMARY SINGLE PHASE FAILURE.
  - ALL UNIT POWER WIRING MUST BE COPPER CONDUCTORS ONLY AND HAVE A MINIMUM TEMPERATURE INSULATION RATING OF 75 DEGREE C (165A - 0-598) OR 90 DEGREE C (182A - 779). SEE UNIT NAMEPLATE FOR MINIMUM CIRCUIT AMPACITY AND MAXIMUM FUSE SIZE REQUIREMENTS. USE 600 VOLT COPPER CONDUCTORS ONLY. 200 TO 600 VOLT CIRCUIT, PROVIDE AN EQUIPMENT GROUNDING IN ACCORDANCE WITH APPLICABLE ELECTRIC CODES.
  - THESE FEATURES ARE OPTIONAL AND MAY OR MAY NOT BE PROVIDED. CUSTOMER PROVIDED WIRING FOR ALL STANDARD FEATURES AND OPTIONS IS SHOWN ON THIS DIAGRAM. OPTIONAL FEATURES ARE SO NOTED.
  - OPENING THE EXTERNAL AUTO-STOP CONTACT WILL INITIATE A SHUT-DOWN SEQUENCE OF THE CHILLER. CLOSURE OF THE CONTACT WILL ALLOW THE CHILLER TO RETURN TO NORMAL AUTOMATIC OPERATION.
  - AN OPENING OF THE EMERGENCY STOP CONTACT WILL SHUT THE CHILLER DOWN IMMEDIATELY AND TRIGGER AN EMERGENCY STOP INPUT DIAGNOSTIC CLOSURE OF THE CONTACT AND A MANUAL RESET OF THE UNIT CONTROL DIAGNOSTIC WILL ALLOW THE CHILLER TO RETURN TO NORMAL OPERATION.
  - ICE BUILDING CONTROL 1A8 MODULE IS OPTIONAL.
- WIRING REQUIREMENTS**
- RECOMMENDED FIELD WIRING CONNECTIONS ARE SHOWN BY DASHED LINES
  - ALL FIELD WIRING MUST BE IN ACCORDANCE WITH THE NATIONAL ELECTRIC CODE AND STATE AND LOCAL REQUIREMENTS. EXPORT UNIT WIRING MUST COMPLY WITH LOCAL APPLICABLE CODES.
  - LINE VOLTAGE OPTIONS: UNIT MOUNTED TERMINAL BLOCK, DISCONNECT OR HACR CIRCUIT BREAKER. THE POWER WIRING LUG SIZE PROVIDED ON THE VARIOUS UNITS IS SHOWN IN TABLE 1.
  - CLASS I WIRING: 14 AWG, 600 VOLT CONDUCTORS. 115 VOLT CIRCUIT
  - ALL CUSTOMER CONTROL CIRCUIT WIRING MUST BE COPPER CONDUCTORS ONLY AND HAVE A MINIMUM INSULATION RATING OF 300 VOLTS. EXCEPT AS NOTED ALL CUSTOMER WIRING CONNECTIONS ARE MADE TO CIRCUIT BOARD MOUNTED BOX LUGS WITH A WIRE RANGE OF 14 TO 18 AWG.
  - DO NOT RUN LOW VOLTAGE CONTROL WIRING (30 VOLTS OR LESS) IN CONDUIT WITH 110 VOLT OR HIGHER WIRING. DO NOT EXCEED THE FOLLOWING MAXIMUM RUN LENGTHS FOR A GIVEN SIZE: 14 AWG, 500 FT (15 AWG, 200 FT); 16 AWG, 1000 FT.
  - TRANE TRACER SUMMIT RECOMMENDED WIRE: TRANE IS SHIELDED TWISTED PAIR COMMUNICATION CABLE 14-18 AWG, 800V CABLE, 30 VOLT CIRCUIT. THE SUM TOTAL LENGTH OF ALL INTERCONNECTED CABLE SEGMENTS NOT TO EXCEED 4500 FEET. CONNECTION TECHNOLOGY SHOULD BE DASHY CHAIN. REFER TO BUILDING AUTOMATION SYSTEM (BAS) COMMUNICATION INSTALLATION LITERATURE FOR END OF LINE TERMINATION RESISTOR REQUIREMENTS.
- LINKAGE COMMUNICATION INTERFACE (LCI) RECOMMENDED WIRE:**
- 22 AWG LEVEL 4 UNSHIELDED COMMUNICATION WIRE. RECOMMENDED. THE SUM TOTAL LENGTH OF ALL INTERCONNECTED CABLE SEGMENTS NOT TO EXCEED 4500 FEET. CONNECTION TECHNOLOGY SHOULD BE DASHY CHAIN. REFER TO BUILDING AUTOMATION SYSTEM (BAS) COMMUNICATION INSTALLATION LITERATURE FOR END OF LINE TERMINATION RESISTOR REQUIREMENTS.

- THE CONTACTS FOR THESE FEATURES ARE JUMPED AT THE FACTORY BY JUMPERS W1 & W2 TO ENABLE UNIT OPERATION IF REMOTE CONTROL IS DESIRED REMOVE THE JUMPERS AND CONNECT TO THE DESIRED CONTROL CIRCUIT.
  - FIELD PROVIDED 115 VOLT 60HZ OR 220V VOLT 50HZ CONTROL POWER SUPPLIES ARE REQUIRED. THE MAX FUSE SIZE FOR ALL FIELD PROVIDED WIRING IS 15 AMPS. GROUND ALL CUSTOMER PROVIDED POWER SUPPLIES AS REQUIRED BY CODE. GREEN GROUND SCREWS ARE PROVIDED IN UNIT CONTROL PANEL.
  - CHILLED/CONDENSER WATER PUMP STARTER AUXILIARY CONTACTS TO BE WIRED IN SERIES WITH FLOW SWITCHES.
  - WHEN ORDERED THE OUTDOOR AIR TEMP SENSOR ELECTRONICS IS FACTORY MOUNTED INSIDE THE CONTROL PANEL AND THE IPC BUS IS FACTORY WIRED. THE SENSOR IS TO BE FIELD WIRED EXTERNALLY WITH THE SENSOR LEAD EXTENDED BACK TO THE CONTROL PANEL. THESE WIRING CAN BE SPliced WITH TWO 14-18 AWG 600V WIRES WITH A MAXIMUM LENGTH OF 1000 FEET (305 METERS). SPlice AT SENSOR END MUST BE WATER TIGHT. REFER TO UNIT IOM FOR DETAILS.
- CONTACT RATINGS AND REQUIREMENTS**
- UNIT PROVIDED DRY CONTACTS FOR THE CONDENSER/CHILLED WATER PUMP CONTROL. THE UNIT OPERATING STATUS RELAYS AND ICE MAKING STATUS RELAY ARE RATED FOR 7.2 AMPS RESISTIVE, 2.88 AMPS PLUG DUTY, OR 1/3 HP, 7.2 FLA AT 120 VOLTS 60 HZ. CONTACTS ARE RATED FOR 5 AMPS GENERAL PURPOSE DUTY AT 240 VOLTS.
  - CUSTOMER SUPPLIED CONTACTS FOR ALL LOW VOLTAGE CONNECTIONS MUST BE COMPATIBLE WITH DRY CIRCUIT 24 VOLTS DC FOR A 12 MA RESISTIVE LOAD. SILVER OR GOLD PLATED CONTACTS ARE RECOMMENDED.
  - FLOW SWITCH AND INTERLOCK CONTACTS MUST BE ACCEPTABLE FOR USE IN A 120 VOLT 1MA CIRCUIT OR A 220 VOLT 2MA CIRCUIT.
  - THE FIELD PROVIDED INDICATORS MAY BE RELAYS, LIGHTS OR AUDIBLE DEVICES. EACH FUNCTION IS ASSOCIATED WITH A SPOT RELAY. THE INDICATOR FUNCTIONS MAY BE CONNECTED TO EITHER OR BOTH OF THE NORMALLY OPEN OR NORMALLY CLOSED RELAY CONTACTS OF EACH OF THE 4 SPOT RELAYS ON THE OPTIONAL UNIT OPERATING STATUS MODULE. THE FUNCTIONS OF THE OPERATING STATUS MODULE RELAYS ARE PROGRAMMABLE. SEE IOM FOR DETAILS. DEFAULT FUNCTIONS ARE SHOWN. THE NORMALLY OPEN CONTACTS ON EACH RELAY OPERATE AS FOLLOWS:  
COMPRESSOR — THE NO CONTACTS CLOSE WHEN COMPRESSOR STATUS FROM STARTER MODULE IS EITHER STARTING OR RUNNING.  
ALARM RELAY — THE NO CONTACTS CLOSE WHEN THERE IS AN DIAGNOSTIC THAT HAS CAUSED A CHILLER SHUTDOWN WITH EITHER A MANUAL RESET REQUIRED OR AN AUTOMATIC RESET POTENTIAL.  
CHILLER LIMIT MODE RELAY — THE NO CONTACTS CLOSE WHENEVER THE CHILLER HAS BEEN RUNNING IN ONE OF THE UNLOADING TYPES OF LIMIT MODES (CONDENSER, EVAPORATOR, CURRENT LIMIT OR PHASE IMBALANCE LIMIT) CONTINUOUSLY FOR THE LAST 20 MINUTES.
  - HEAD PRESSURE RELIEF REQUEST — THE NO CONTACTS CLOSE ANYTIME THE CHILLER IS RUNNING IN ONE OF THE FOLLOWING MODES: ICE MAKING MODE OR CONDENSER PRESSURE LIMIT CONTROL MODE CONTINUOUSLY FOR THE DURATION SPECIFIED BY THE CHILLER HEAD RELIEF RELAY FIELD TAG.
  - FIELD SELECTABLE AS: CONDENSER PRESSURE, DELTA PRESSURE OR CONTROL OUTPUT SIGNAL FOR CONDENSER HEAD PRESSURE CONTROL.
  - THE FIELD WIRING FOR THE 115V HOT LUG IS TERMINATED TO 1A8 TERMINAL BLOCK. SEE INSTRUCTION LABEL IN CONTROL PANEL FOR WIRE INSULATION INSTRUCTIONS. SPlice FIELD WIRES TOGETHER AND WIRE TO 1A8.
  - CLOSED CONTACT COMMANDS BASE LOADING OPERATION.
  - ACTUAL BASE LOADING SETPOINT USED IS SETTABLE AT FRONT PANEL. REFER TO IOM FOR DETAILS.
  - OPTIONAL MODULES. ONLY PRESENT WHEN HEAT RECOVERY IS REQUIRED.

# Dimensions and Weights

## Shipping and Operating Weights

Compressor Code	Evaporator Code	Condenser Code	Operating weight		Shipping Weight	
			(lbs)	(kg)	(lbs)	(kg)
B1	B1	B1	9,350	4,241	8,774	3,980
B1	C1	D1	10,064	4,565	9,347	4,240
B2	B2	B2	9,469	4,295	8,851	4,015
B2	C2	D2	10,205	4,629	9,436	4,280
BE	C2	D2	10,271	4,659	9,502	4,310
C1	C2	D2	12,013	5,449	11,243	5,100
C1	D3	E3	13,521	6,133	12,478	5,660
C1	D6	E5	12,544	5,690	11,927	5,410
C1	D5	E4	12,782	5,798	12,081	5,480
C1	E1	F1	14,312	6,492	13,128	5,955
C2	D4	E4	12,826	5,818	12,125	5,500
C2	D3	E3	13,510	6,128	12,467	5,655
C2	E1	F1	14,312	6,492	13,128	5,955
C2	F2	F3	15,467	7,016	14,065	6,380
CE	F2	F3	15,653	7,100	14,198	6,440
D1	D1	E1	13,970	6,337	13,029	5,910
D1	F1	F2	15,944	7,232	14,616	6,630
D1	G1	G1	18,131	8,224	16,336	7,410
D2, D3	D2	E2	14,127	6,408	13,117	5,950
D3	G3	G3	19,138	8,681	17,019	7,720
D2, D3	F2	F3	16,173	7,336	14,771	6,700
D2, D3	G2	G1	18,307	8,304	16,446	7,460
DE	H3	G3	18,464	8,375	17,240	7,820
E3	D2	E2	15,428	6,998	14,718	6,676
E3	F2	F3	16,481	7,476	15,079	6,840
E3	G2	G1	18,571	8,424	16,711	7,580
E3	G3	G3	19,403	8,801	17,284	7,840
EE	H3	G3	19,434	8,815	18,078	8,200
B1	C1	H1	12,046	5,464	10,813	4,905
B2	C2	H2	12,264	5,563	11,058	5,016
C1	E1	J1	18,896	8,571	16,940	7,684
C2	F2	J3	20,483	9,291	18,300	8,301
D1	F1	J2	21,027	9,538	18,776	8,517
D2, D3	G2	K1	22,187	10,064	19,365	8,784
E3	G2	K1	22,253	10,094	19,431	8,814
B1	C1	L1	10,891	4,940	9,932	4,505
B2	C2	L2	11,054	5,014	10,121	4,591
C1	E1	M1	16,616	7,537	15,132	6,864
C2	F2	M3	18,208	8,259	16,481	7,476
D1	F1	M2	18,774	8,516	17,002	7,712
D2, D3	G2	N1	20,597	9,343	18,208	8,259
E3	G2	N1	20,664	9,373	18,274	8,289

**Notes:**

1. All weights +/- 3%.
2. Shipping weights include standard 150 psig water boxes, refrigerant charge, and oil charge.
3. Operating weights include refrigerant, oil, and water charges.

# Dimensions

150psig(1.0MPa)

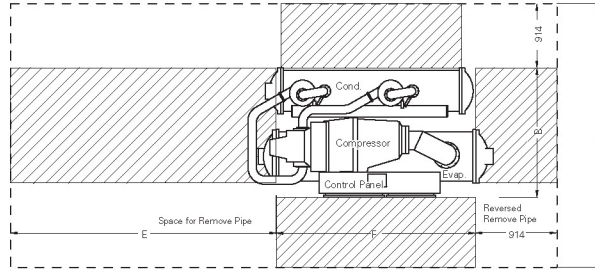

Space Layout

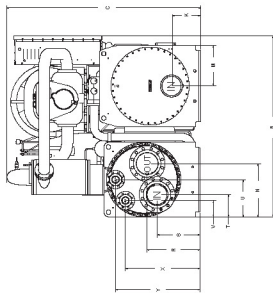

Partial Heat Recovery

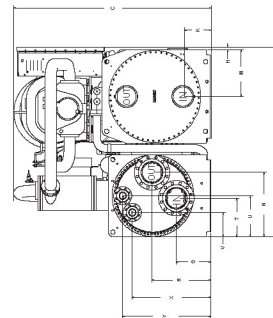

Partial Heat Recovery

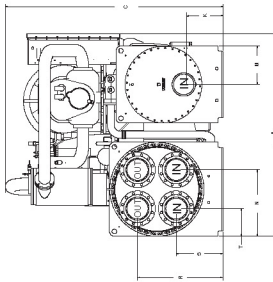

Total Heat Recovery

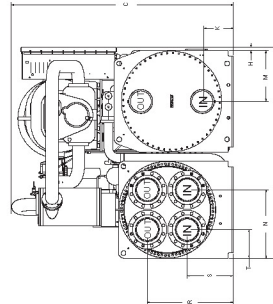

Total Heat Recovery

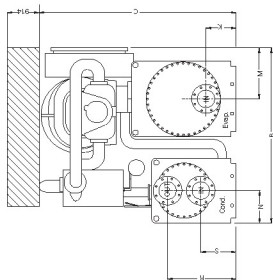

Standard chiller

3 pass in Evap.

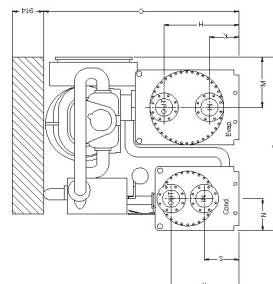

Standard chiller

2(or 4) pass in Evap.

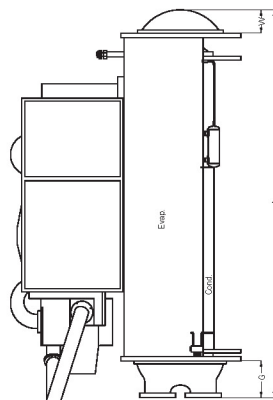
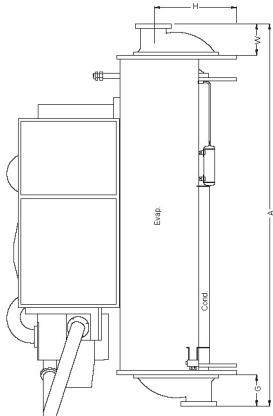

# Dimensions Sheet

150psig (1.0MPa)

Model	Evap. Pass	mm													
		A	B	C	D	E	F	G	H	K	M	N	R	S	W
B1B1B1	3	3414	1634	1849	3475	2743	2730	340	726	351	580	292	622	349	340
B1C1D1	3	3878	1634	1849	3475	3200	3194	340	726	351	580	292	622	349	340
B2B2B2	3	3414	1634	1849	3475	2743	2730	340	726	351	580	292	622	349	340
B2C2D2	3	3878	1634	1849	3475	3200	3194	340	726	351	580	292	622	349	340
BEC2D2	3	3878	1634	1849	3475	3200	3194	340	726	351	580	292	622	349	340
C1C2D2	3	3878	1695	1870	3536	3200	3194	340	726	351	641	292	622	349	340
C1D6E5	3	3534	1717	1937	3557	2743	2730	400	765	378	503	318	692	358	400
C1D5E4	3	3534	1717	1937	3557	2743	2730	400	765	378	503	318	692	358	400
C1D3E3	4	3534	1717	1937	3557	2743	2730	285	793	349	503	318	692	358	181
C1E1F1	3	3998	1717	1937	3557	3200	3194	400	765	378	503	318	692	358	400
C2D4E4	3	3534	1717	1937	3557	2743	2730	400	765	378	503	318	692	358	400
C2D3E3	3	3534	1717	1937	3557	2743	2730	400	765	378	503	318	692	358	400
C2E1F1	4	3534	1717	1937	3557	3200	3194	285	793	349	503	318	692	358	181
C2F2F3	3	3958	1717	1937	3557	3200	3194	380	722	290	503	318	692	358	380
CEF2F3	3	3958	1717	1937	3557	3200	3194	380	722	290	503	318	692	358	380
D1D1E1	3	3534	1717	1937	3557	2743	2730	400	765	378	503	318	692	358	400
D1F1F2	3	3958	1717	1937	3557	3200	3194	380	722	290	503	318	692	358	380
D1G1G1	4	4012	1771	2033	3615	3302	3289	390	861	289	503	373	739	405	235
D2D2E2	3	3534	1717	1937	3557	2743	2730	400	765	378	503	318	692	358	400
D2F2F3	3	3958	1717	1937	3557	3200	3194	380	722	290	503	318	692	358	380
D2G2G1	4	4012	1771	2033	3615	3302	3289	390	861	289	503	373	739	405	235
D3D2E2	3	3534	1717	1937	3557	2743	2730	260	765	378	503	318	692	358	260
D3F2F3	3	3958	1717	1937	3557	3200	3194	380	722	290	503	318	692	358	380
D3G2G1	4	4012	1771	2033	3615	3302	3289	390	861	289	503	373	739	405	235
D3G3G3	4	4012	1771	2033	3615	3302	3289	390	861	289	503	373	739	405	235
DEH3G3	3	4152	1771	2033	3615	3302	3289	390	861	310	473	373	701	405	390
E3F2F3	3	3958	1717	1937	3557	3200	3194	380	722	290	503	318	692	358	380
E3G2G1	4	4012	1771	2033	3615	3302	3289	390	861	289	503	373	739	405	235
E3G3G3	4	4012	1771	2033	3615	3302	3289	390	861	289	503	373	739	405	235
EEH3G3	3	4152	1771	2033	3615	3302	3289	390	861	310	473	373	701	405	390

Model	Evap. Pass	mm																		
		A	B	C	D	E	F	G	H	K	M	N	R	S	W	T	U	V	X	Y
B1C1H1	3	3674	1830	1919	3670	3200	3194	240	726	351	580	572	668	362	240	258				
B2C2H2	3	3674	1830	1919	3670	3200	3194	240	726	351	580	572	668	362	240	258				
C1E1J1	3	3712	1953	2078	3793	3200	3194	260	765	378	503	635	815	445	261	265				
C2F2J3	3	3736	1953	2078	3793	3200	3194	272	722	290	503	635	815	445	272	265				
D1F1J2	3	3736	1953	2078	3793	3200	3194	272	722	290	503	635	815	445	272	265				
D2G2K1	4	3774	1960	2061	3800	3302	3289	310	861	289	503	635	796	426	235	265				
D3G2K1	4	3774	1960	2061	3800	3302	3289	310	861	289	503	635	796	426	235	265				
E3G2K1	4	3774	1960	2061	3800	3302	3289	310	861	289	503	635	796	426	235	265				
B1C1L1	3	3674	1701	1892	3541	3200	3194	240	726	351	580	447	384	354	240	183	318	152	569	672
B2C2L2	3	3674	1701	1892	3541	3200	3194	240	726	351	580	447	384	354	240	183	318	152	569	672
C1E1M1	3	3712	1814	1949	3654	3200	3194	260	765	378	503	537	531	431	261	223	375	164	750	850
C2F2M3	3	3736	1814	1949	3654	3200	3194	272	722	290	503	537	531	431	272	223	375	164	750	850
D1F1M2	3	3736	1814	1949	3654	3200	3194	272	722	290	503	537	531	431	272	223	375	164	750	850
D2G2N1	4	3774	1925	2002	3765	3302	3289	310	861	289	503	652	598	352	235	390	415	245	798	896
D3G2N1	4	3774	1925	2002	3765	3302	3289	310	861	289	503	652	598	352	235	390	415	245	798	896
E3G2N1	4	3774	1925	2002	3765	3302	3289	310	861	289	503	652	598	352	235	390	415	245	798	896

- Notes:  
 1. Data deviation ±15mm;  
 2. Nozzle head direction of evaporator and condenser on standard chiller are all at left;  
 3. Above data are some selection examples, please contact Trane sales for more details.





# Mechanical Specifications

## General

Exposed metal surfaces are painted with air-dry beige, direct-to-metal, single-component paint. Each unit ships with full operating charges of refrigerant and oil. Molded neoprene isolation pads are supplied for placement under all support points. Startup and operator instruction by factory-trained service personnel are included.

## Compressor and Motor

The unit is equipped with a semihermetic, direct-drive, 3600-rpm (3000 rpm @ 50 Hz) rotary compressor that includes a capacity control slide valve, oil sump heater, and differential pressure refrigerant oil flow system.

Four pressure-lubricated, rollingelement bearing groups support the rotating assembly. The motor is a suction gas-cooled, hermetically sealed, two-pole, squirrel cage induction-type.

## Unit-Mounted Starter

The unit is supplied with a NEMA 1 type enclosure with top power-wiring access and three-phase, solid state overload protection. The starter is available in a Wye-Delta configuration, factory-mounted and fully pre-wired to the compressor motor and control panel. A factory-installed, factory-wired 600VA control power transformer provides all unit control power (120 VAC secondary) and UC800 module power (24 VAC secondary). Optional starter features include circuit breakers, ground fault circuit breakers, and mechanical, non-fused disconnects.

## Evaporator and Condenser

Shells are carbon steel plate. The evaporator and condenser are designed, tested, and stamped in accordance with ASME Code for refrigerant-side/working-side pressure of 200 psig. All tube sheets are made of carbon steel; tubes are mechanically expanded into tube sheets and mechanically fastened to tube supports. Evaporator tubes are 1.0-inch (25.4 mm) diameter and condenser tubes are 0.75-inch (19.05 mm) diameter. Both types can be individually replaced.

Standard tubes are externally finned, internally enhanced seamless copper with lands at all tube sheets.

All water pass arrangements are available with flange connections (150 or 300 psig waterside). All connections may be either right- or left-handed.

Waterside shall be hydrostatically tested at 1.5X design working pressure.

## Refrigerant Circuit

An electronically controlled expansion valve is provided to maintain proper refrigerant flow.

## Tracer Adapti View TD7 Display

The Tracer AdaptiView™ TD7 is a 7" diagonal 16 bit graphic color display with 800x480 pixels and TFT LCD@ 600 nits brightness. The display provides alarms, reports, settings as well as graphing.

The display supports 26 languages and complies with the following standards: IP56, RoHS, UL 916, CE, EN55011 (class B), and EN61000 (Industrial).

## Unit Controls

All controls, including sensors, are factory mounted and tested prior to shipment. Microcomputer controls provide all control functions including startup and shut down, leaving chilled water temperature control, evaporator flow proving, compressor staging and speed control, electronic expansion valve modulation, anti-recycle logic, automatic lead/lag compressor starting and load limiting.



The Tracer™ UC800 unit control module, utilizing Adaptive Control™ microprocessor, automatically takes action to avoid unit shut-down due to abnormal operating conditions associated with low refrigerant pressure, high condensing pressure, AFD/Compressor current overload, low oil return or low AFD cooling, low discharge superheat, and high compressor discharge temperature. Should the abnormal operating condition continue until a protective limit is violated, the unit will be shut down. Unit protective functions of the UC800, include loss of chilled water flow, evaporator freezing, loss of refrigerant, low refrigerant pressure, high refrigerant pressure, high compressor motor temperature, and loss of oil to the compressor.

A full color Tracer AdaptiView TD7 touch screen display indicates all important unit and circuit parameters, in logical groupings on various screens. The parameters including chilled water set point, leaving chilled water temperature, demand limit set point, evaporator and condenser refrigerant temperatures and pressures, compressor speeds, and all pertinent electrical information. The display also provides "on screen" trending graphs of predefined parameters as well as customizable trend graphs based on user defined parameters from a list of all available parameters. The display also provides indication of the chiller and circuits' top level operating modes with detailed sub-mode reports available with a single key press, as well as diagnostics annunciation and date and time stamped diagnostic history.

Standard power connections include main three phase power to the compressors, control power transformer and optional connections are available for the 115 volt/60 Hz single phase power for the thermostatically controlled evaporator heaters for freeze protection.

## Clear Language Display Panel

Factory-mounted to the control panel door, the operator interface has an LCD touch-screen display for operator input and information output. This interface provides access to the following information: evaporator report, condenser report, compressor report, ASHRAE Guideline 3 report, operator settings, service settings, service tests, and diagnostics. All diagnostics and messages are displayed in "clear language."

Data contained in available reports includes:

- Water and air temperatures
- Refrigerant levels and temperatures
- Oil pressure
- Flow switch status
- EXV position
- Head pressure control command
- Compressor starts and run-time
- Line phase percent RLA, amps, and volts

All necessary settings and setpoints are programmed into the microprocessorbased controller via the operator interface. The controller is capable of receiving signals contemporaneously from a variety of control sources, in any combination, and priority order of control sources can be programmed.

The control source with priority determines active setpoints via the signal it sends to the control panel.

Control sources may be:

- the local operator interface (standard)
- a hard-wired 4-20 mA or 2-10 VDC signal from an external source (interface optional; control source not supplied)
- Generic BAS (optional points; control source not supplied)
- LonTalk LCI-C (interface optional; control source not supplied)
- Trane Tracer Summit™ system (interface optional)



# Conversion Table

To Convert From:	To:	Multiply By:	To Convert From:	To:	Multiply By:
<b>Length</b>			<b>Energy and Power and Capacity</b>		
Feet (ft)	meters (m)	0.30481	British Thermal Units (BTUH)	Kilowatt (kW)	0.000293
Inches (In)	millimeters (mm)	25.4	British Thermal Units (BTU)	KCalorie (Kcal)	0.252
<b>Area</b>			Tons (refrig. effect)	Kilowatt (refrig. effect)	3.516
Square Feet (ft <sup>2</sup> )	square meters (m <sup>2</sup> )	0.093	Tons (refrig. effect)	Kilocalories per hour (Kcal/hr)	3024
Square Inches (In <sup>2</sup> )	square millimeters (mm <sup>2</sup> )	645.2	Horsepower	Kilowatt (kW)	0.7457
<b>Volume</b>			<b>Pressure</b>		
Cubic Feet (ft <sup>3</sup> )	Cubic meters (m <sup>3</sup> )	0.0283	Feet of water (ftH <sub>2</sub> O)	Pascals (PA)	2990
Cubic Inches (In <sup>3</sup> )	Cubic mm (mm <sup>3</sup> )	16387	Inches of water (inH <sub>2</sub> O)	Pascals (PA)	249
Gallons (gal)	litres (l)	3.785	Pounds per square inch (PSI)	Pascals (PA)	6895
Gallons (gal)	cubic meters (m <sup>3</sup> )	0.003785	PSI	Bar or KG/CM <sup>2</sup>	6.895 x 10 <sup>-2</sup>
<b>Flow</b>			<b>Weight</b>		
Cubic feet/min (cfm)	cubic meters/second (m <sup>3</sup> /s)	0.000472	Ounces (oz)	Kilograms (kg)	0.02835
Cubic Feet/min (cfm)	cubic meters/hr (m <sup>3</sup> /hr)	1.69884	Pounds (lbs)	Kilograms (Kg)	0.4536
Gallons/minute (GPM)	cubic meters/hr (m <sup>3</sup> /hr)	0.2271	<b>Fouling factors for heat exchangers</b>		
Gallons/minute (GPM)	litres/second (l/s)	0.06308	0.00075 ft <sup>2</sup> °F hr/BTU	= 0.132 m <sup>2</sup> °K/kW	
<b>Velocity</b>			0.00025 ft <sup>2</sup> °F hr/BTU	= 0.044 m <sup>2</sup> °K/kW	
Feet per minute (ft/m)	meters per second (m/s)	0.00508			
Feet per second (ft/s)	meters per second (m/s)	0.3048			

## Temperature – Centigrade (°C) Versus Fahrenheit (°F)

Note: The center columns of numbers, referred to as BASE TEMP., is the temperature in either degrees Fahrenheit (°F) or Centigrade (°C), whichever is desired to convert into the other. If degrees Centigrade is given, read degrees Fahrenheit to the right. If degrees Fahrenheit is given, read degrees Centigrade to the left.

Temperature			Temperature			Temperature			Temperature			Temperature		
°C	C or F	°F	°C	C or F	°F	°C	C or F	°F	°C	C or F	°F	°C	C or F	°F
-40.0	-40	-40.0	-15.0	+5	+41.0	+10.0	+50	+122.0	+35.0	+95	+203.0	+60.0	+140	+284.0
-39.4	-39	-38.2	-14.4	+6	+42.8	+10.6	+51	+123.8	+35.6	+96	+204.8	+60.6	+141	+285.8
-38.9	-38	-36.4	-13.9	+7	+44.6	+11.1	+52	+125.6	+36.1	+97	+206.6	+61.1	+142	+287.6
-38.3	-37	-34.6	-13.3	+8	+46.4	+11.7	+53	+127.4	+36.7	+98	+208.4	+61.7	+143	+289.4
-37.8	-36	-32.8	-12.8	+9	+48.2	+12.2	+54	+129.2	+37.2	+99	+210.2	+62.2	+144	+291.2
-37.2	-35	-31.0	-12.2	+10	+50.0	+12.8	+55	+131.0	+37.8	+100	+212.0	+62.8	+145	+293.0
-36.7	-34	-29.2	-11.7	+11	+51.8	+13.3	+56	+132.8	+38.3	+101	+213.8	+63.3	+146	+294.8
-36.1	-33	-27.4	-11.1	+12	+53.6	+13.9	+57	+134.6	+38.9	+102	+215.6	+63.9	+147	+296.6
-35.6	-32	-25.6	-10.6	+13	+55.4	+14.4	+58	+136.4	+39.4	+103	+217.4	+64.4	+148	+298.4
-35.0	-31	-23.8	-10.0	+14	+57.2	+15.0	+59	+138.2	+40.0	+104	+219.2	+65.0	+149	+300.2
-34.4	-30	-22.0	-9.4	+15	+59.0	+15.6	+60	+140.0	+40.6	+105	+221.0	+65.6	+150	+302.0
-33.9	-29	-20.2	-8.9	+16	+60.8	+16.1	+61	+141.8	+41.1	+106	+222.8	+66.1	+151	+303.8
-33.3	-28	-18.4	-8.3	+17	+62.6	+16.7	+62	+143.6	+41.7	+107	+224.6	+66.7	+152	+305.6
-32.8	-27	-16.6	-7.8	+18	+64.4	+17.2	+63	+145.4	+42.2	+108	+226.4	+67.2	+153	+307.4
-32.2	-26	-14.8	-7.2	+19	+66.2	+17.8	+64	+147.2	+42.8	+109	+228.2	+67.8	+154	+309.2
-31.7	-25	-13.0	-6.7	+20	+68.0	+18.3	+65	+149.0	+43.3	+110	+230.0	+68.3	+155	+311.0
-31.1	-24	-11.2	-6.1	+21	+69.8	+18.9	+66	+150.8	+43.9	+111	+231.8	+68.9	+156	+312.8
-30.6	-23	-9.4	-5.5	+22	+71.6	+19.4	+67	+152.6	+44.4	+112	+233.6	+69.4	+157	+314.6
-30.0	-22	-7.6	-5.0	+23	+73.4	+20.0	+68	+154.4	+45.0	+113	+235.4	+70.0	+158	+316.4
-29.4	-21	-5.8	-4.4	+24	+75.2	+20.6	+69	+156.2	+45.6	+114	+237.2	+70.6	+159	+318.2
-28.9	-20	-4.0	-3.9	+25	+77.0	+21.1	+70	+158.0	+46.1	+115	+239.0	+71.1	+160	+320.0
-28.3	-19	-2.2	-3.3	+26	+78.8	+21.7	+71	+159.8	+46.7	+116	+240.8	+71.7	+161	+321.8
-27.8	-18	-0.4	-2.8	+27	+80.6	+22.2	+72	+161.6	+47.2	+117	+242.6	+72.2	+162	+323.6
-27.2	-17	+1.4	-2.2	+28	+82.4	+22.8	+73	+163.4	+47.8	+118	+244.4	+72.8	+163	+325.4
-26.7	-16	+3.2	-1.7	+29	+84.2	+23.3	+74	+165.2	+48.3	+119	+246.2	+73.3	+164	+327.2
-26.1	-15	+5.0	-1.1	+30	+86.0	+23.9	+75	+167.0	+48.9	+120	+248.0	+73.9	+165	+329.0
-25.6	-14	+6.8	-0.6	+31	+87.8	+24.4	+76	+168.8	+49.4	+121	+249.8	+74.4	+166	+330.8
-25.0	-13	+8.6	0.0	+32	+89.6	+25.0	+77	+170.6	+50.0	+122	+251.6	+75.0	+167	+332.6
-24.4	-12	+10.4	+0.6	+33	+91.4	+25.6	+78	+172.4	+50.6	+123	+253.4	+75.6	+168	+334.4
-23.9	-11	+12.2	+1.1	+34	+93.2	+26.1	+79	+174.2	+51.1	+124	+255.2	+76.1	+169	+336.2
-23.3	-10	+14.0	+1.7	+35	+95.0	+26.7	+80	+176.0	+51.7	+125	+257.0	+76.7	+170	+338.0
-22.8	-9	+15.8	+2.2	+36	+96.8	+27.2	+81	+177.8	+52.2	+126	+258.8	+77.2	+171	+339.8
-22.2	-8	+17.6	+2.8	+37	+98.6	+27.8	+82	+179.6	+52.8	+127	+260.6	+77.8	+172	+341.6
-21.7	-7	+19.4	+3.3	+38	+100.4	+28.3	+83	+181.4	+53.3	+128	+262.4	+78.3	+173	+343.4
-21.1	-6	+21.2	+3.9	+39	+102.2	+28.9	+84	+183.2	+53.9	+129	+264.2	+78.9	+174	+345.2
-20.6	-5	+23.0	+4.4	+40	+104.0	+29.4	+85	+185.0	+54.4	+130	+266.0	+79.4	+175	+347.0
-20.0	-4	+24.8	+5.0	+41	+105.8	+30.0	+86	+186.8	+55.0	+131	+267.8	+80.0	+176	+348.8
-19.4	-3	+26.6	+5.5	+42	+107.6	+30.6	+87	+188.6	+55.6	+132	+269.6	+80.6	+177	+350.6
-18.9	-2	+28.4	+6.1	+43	+109.4	+31.1	+88	+189.4	+56.1	+133	+271.4	+81.1	+178	+352.4
-18.3	-1	+30.2	+6.7	+44	+111.2	+31.7	+89	+192.2	+56.7	+134	+273.2	+81.7	+179	+354.2
-17.8	0	+32.0	+7.2	+45	+113.0	+32.2	+90	+194.0	+57.2	+135	+275.0	+82.2	+180	+356.0
-17.2	+1	+33.8	+7.8	+46	+114.8	+32.8	+91	+195.8	+57.8	+136	+276.8	+82.8	+181	+357.8
-16.7	+2	+35.6	+8.3	+47	+116.6	+33.3	+92	+197.6	+58.3	+137	+278.6	+83.3	+182	+359.6
-16.1	+3	+37.4	+8.9	+48	+118.4	+33.9	+93	+199.4	+58.9	+138	+280.4	+83.9	+183	+361.4
-15.6	+4	+39.2	+9.4	+49	+120.2	+34.4	+94	+201.2	+59.4	+139	+282.2	+84.4	+184	+363.2

### FOR INTERPOLATION IN THE ABOVE TABLE USE:

BASE TEMPERATURE (°F or °C)	1	2	3	4	5	6	7	8	9	10
DEGREES CENTIGRADE:	0.56	1.11	1.67	2.22	2.78	3.33	3.89	4.44	5.00	5.56
DEGREES FAHRENHEIT:	1.8	3.6	5.4	7.2	9.0	10.8	12.6	14.4	16.2	18.0

Trane - by Trane Technologies (NYSE:TT), a global climate innovator - creates comfortable, energy efficient indoor environments for commercial and residential applications. For more information, please visit [trane.com](http://trane.com) or [tranetechnologies.com](http://tranetechnologies.com).

Trane has a policy of continuous product and product data improvement and reserves the right to change design and specifications without notice. We are committed to using environmentally conscious print practices.

RLC-PRC031H-EN August 2021  
Supersedes RLC-PRC031G-EN (October 2019)

©2021 Trane