

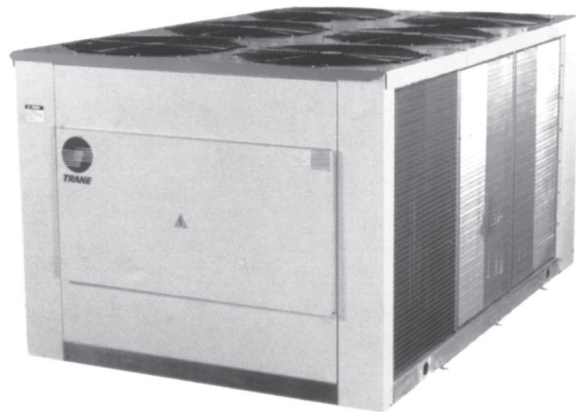

CGAP

R22/R407C

**Air Cooled Scroll Liquid Chillers
Cooling Only 60-210 kW
50Hz**



690826950001

**CGAP- CATALOGUE
Rev.A**

Contents

Standard Product Model Nomenclature	3
CGAP General Data	4
Standard and Optional Features	5
Application Consideration	6
Mechanical Specification	8
CGAP Performance Data (IP Units)	9
CGAP Performance Data (SI Units)	10
Pressure Drop, Correction Factor	11
Selection Procedures	11
Dimensional Drawing	12
Wiring Diagram	16
Standard Conversion Table	22

Standard Product Model Nomenclature

C **G** **A** **P** **0** **2** **5** **D** **1** **A** **0** **A** **0** **0** **A**
 1 2 3 4 5 6 7 8 9 10 11 12 13 14 15

DIGIT 1,2,3	C G A	Chiller Unit / Cooling Only / Air-Cooled
DIGIT 4	P	Development Sequence
DIGIT 5,6,7	0 2 5	Nominal Gross Capacity (MBH) (Note : The Alphabetic Letter "O" is not used in Digit 6 or 7, Only the Number "0" is used.) 025 = 250 MBH 050 = 500 MBH 030 = 300 MBH 060 = 600 MBH 040 = 400 MBH
DIGIT 8	D	Electrical Rating / Utilization Range D = 380 - 415V / 3Phase / 50 Hz
DIGIT 9	1	Motor / Compressor Controls (Note : The Alphabetic Letter "O" is not used in Digit 9, Only the Number "0" is used.) 1 = DOL STARTER with CAREL controller.
DIGIT 10	A	Minor Design Sequence A = CGAP Thailand version
DIGIT 11	0	Factory Installed Options (Note : The Alphabetic Letter "O" is not used in Digit 11, Only the Number "0" is used.) 0 = None 2 = Corrosion Resistant cost with Superhydrophobic 1 = Blue fin 3 = Copper fin
DIGIT 12	A	Refrigerant Type A = R22 E = R407C
DIGIT 13	0	Future use
DIGIT 14	0	Future Use
DIGIT 15	A	Service Indicator



CGAP General Data

[R22/R407C]

UNIT MODELS		CGAP025	CGAP030	CGAP040	CGAP050	CGAP060
POWER CONNECTION	V/ph/Hz	380 - 415/3/50	380 - 415/3/50	380 - 415/3/50	380 - 415/3/50	380 - 415/3/50
MCA¹	A	49	58	74	92	110
PERFORMANCES²						
Gross Cooling Capacity ² [R22]	kW (MBH)	64.5 (220.3)	77.7 (265.2)	100.1 (341.8)	127.1 (433.8)	156.1 (532.8)
Gross Cooling Capacity ² [R407c]	kW (MBH)	61.3 (209.3)	73.8 (252.0)	95.0 (324.7)	120.7 (412.0)	148.3 (506.2)
Unit Capacity Steps (%)		100-50	100-50	100-75-50-25	100-75-50-25	100-75-50-25
Sound Power Level	dB (A)	87	89	89	90	92
SYSTEM DATA						
No. Refrigerant Circuits		1	1	2	2	2
Refrigerant Connection Type		Sweat	Sweat	Sweat	Sweat	Sweat
Refrigerant Charge approx. per circuit [R22/R407c]	lb (kg)	26.4 (12.0)	29.7 (13.5)	20.2 (9.2)	26.4 (12.0)	29.7 (13.5)
Suction Line OD	in (mm)	2-1/8	2-1/8	1-5/8	2-1/8	2-1/8
Liquid line OD	in (mm)	7/8	7/8	7/8	7/8	7/8
COMPRESSOR						
Compressor Type		Scroll	Scroll	Scroll	Scroll	Scroll
Qty. Used		2	2	4	4	4
Model		13T+13T	15T+15T	2x(10T+10T)	2x(13T+13T)	2x(15T+15T)
RLA/LRA (each) ²	A	20.5 / 135	24.0 / 175	16.5 / 130	20.5 / 135	24.0 / 175
Motor RPM	rpm	2900	2900	2900	2900	2900
COIL						
Qty. Used		1	1	2	2	2
Tube Type		Plain	Plain	Plain	Plain	Plain
Rows		3	3	3	3	3
Fin Type				Uncoat Corrugated Fin		
Fins per inch		12	12	12	12	12
Refrigerant Flow Control		-	-	-	-	-
EVAPORATOR						
Type				Braze Plate Heat Exchanger		
Water Flowrate	US GPM	45	54	70	88	108.5
Nominal Flow, water PD	ft H ₂ O	7.4	7.5	8	8.3	8.6
Minimum Flowrate	US GPM	33.8	40.5	52.5	66	81.4
Maximum Flowrate	US GPM	56.3	67.5	87.5	110	135.6
Water Strainer				Standard, Accessory, Ship with but installed at site		
Water Connection	MPT	2-1/2"	2-1/2"	2-1/2"	2-1/2"	2-1/2"
FAN						
Fan Type		Propeller	Propeller	Propeller	Propeller	Propeller
No. used		2	3	4	4	6
Diameter	in (mm)	(28) 710	(28) 710	(28) 710	(28) 710	(28) 710
No. of Blade		4	4	4	4	4
Drive Type		Direct	Direct	Direct	Direct	Direct
Nominal Airflow ³	cfm (cmh)	11,500 (19,539)	15,000 (25,485)	17,100 (29,053)	22,280 (37,853)	29,400 (49,950)
MOTOR						
No. of Motor		2	3	4	4	6
Output Motor hp (ea)	hp (kW)	0.4 (0.3)	0.4 (0.3)	0.4 (0.3)	0.4 (0.3)	0.4 (0.3)
No. of Speed		1	1	1	1	1
Motor Speed	rpm	875	875	875	875	875
RLA/LRA (each)		1.32/2.80	1.32/2.80	1.32/2.80	1.32/2.80	1.32/2.80
DIMENSION (HxWxD)						
Crated (Shipping)	in	67x56x103	67x56x126	65x85x113	77x85x113	73x85x128
	mm	1,700x1,420x2,620	1,700x1,420x3,200	1,960x2,160x2,880	1,960x2,160x2,880	1,850x2,160x3,240
Unrated (Net)	in	58x48x90	58x48x116	56x76x102	68x76x102	60x76x117
	mm	1,451x1,222x2,288	1,451x1,222x2,980	1,770x1,923x2,580	1,770x1,923x2,580	1,502x1,921x2,985
WEIGHT						
Crated (Shipping)	lb (kg)	1530 (694)	1,786 (810)	2,394 (1,086)	2,934 (1,331)	2,855 (1,295)
Unrated (Net)	lb (kg)	1489 (674)	1,741 (790)	2,317 (1,051)	2,857 (1,296)	2,778 (1,260)
Minimum Outdoor Air Temperature for Mechanical cooling						
Standard Ambient Operating Range	F	59-133	59-133	59-133	59-133	59-133
	C	15-43	15-43	15-43	15-43	15-43
High Pressure (cut out / cut in)	psig			398 ± 14 / 313 ± 21		
Low Pressure (cut out / cut in)	psig			27 ± 7 / 45.5 ± 7		

¹ MCA - Minimum Circuit Ampacity is 125% of the largest compressor RLA plus 100% of the other compressor RLA plus the sum of the motor RLA.

² At 7 deg C SST and 35 deg C Ambient, **400V**, Subcooling 8.3 K, Superheat 11.1 K. Base on chilled water of EWT&LWT of 54 °F, 44 °F

³ Nominal Airflow is rated with standard air-dry coil.

Standard and Optional Features CGAP Air-Cooler Chillers

Features

Reliability

The compressors used are proven world class hermetically sealed scroll compressors. These scroll compressors are among the industries most resilient and efficient compressors.



Brazed Plate Heat Exchanger With Integrated Distributor

With brazed corrugated stainless steel plates, this compact heat exchanger offers a highly efficient heat transfer rate that is less susceptible to erosion and corrosion while maintaining a homogeneous distribution of refrigerant.

Serviceability

The control and unit panels are completely removable for service accessibility and convenience. "Rapid access" clips and Allen key arrangements allow fast access to the major components in the units.

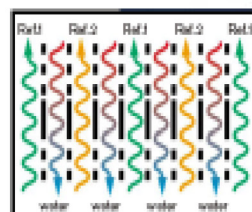

Installation

All chillers are completely factory-wired with necessary capacity and safety controls, enclosed in a weather-tight control panel with knockouts for jobsites installed wiring. This ensures smooth and trouble-free installation. Units arrive at jobsites fully assembled, tested, charged and ready to provide chilled water. No messy field assembly or refrigerant charging is required. Further, the unit has been designed for a single power and water connection.

Optional Features

Corrosion-resistant finned condenser coil

A layer of resin is coated on to the surface of the fins to increase resistance to corrosion in harsh environmental conditions. A 500 hour, salt-spray test (in accordance to JIS-Z-2371) and humidity test (at 50 deg. C, 98% relative humidity) had been performed to confirm the corrosion-proof property of this coating.

Full Packaged Controls

All units come fully packaged with factory engineered starters and electronic controls that give full diagnostic and remote alarms. Integration with Trane tracer summit BMS is available through LONTALK.

Footprint

Central to the design of any project is the operating envelope of the air-cooled packaged chiller. Trane CGAP air-cooled chillers have compact footprints to make the most efficient use of the available installation space. Their modular designs allow max installer space savings on multi unit installations.

Flow Switch

Central Factory installed standard that indicates loss of flow, to prevent damage caused by freezing.

Water Strainers (without installation)

Factory provided to ensure clean water is supplied to the evaporator at times all times.

Application Consideration

Certain application considerations should be considered when sizing, selecting and installing Trane air-cooled chillers. Unit and system reliability often depends upon proper compliance with the following.

Unit Sizing

Unit capacities are listed in the "Performance data" section page 8 to 9. Intentionally oversizing a unit to ensure adequate capacity may result in erratic system operation and excessive compressor cycling. If oversizing is required, consider using more smaller sized units.

Unit Placement Setting the Unit

The unit must be placed on a level location, strong enough to support the operating weight of the unit. A base or foundation is required if the selected unit location is not level or strong enough to support the operating weight of the chiller.

Unit Location

Unobstructed flow of condenser air is essential to maintain chiller capacity and operating efficiency. When determining unit placement, careful consideration must be given to assuring a sufficient flow of air across the condenser heat transfer surface. Two detrimental conditions are possible and must be avoided: warm air re-circulation and coil starvation. Warm air re-circulation occurs when discharge air from the condenser fans is recycled back to the condenser coil inlet. Coil starvation occurs when free air flow to condenser is restricted.

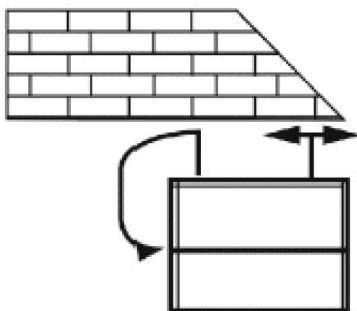

Vertical Clearance

Vertical condenser air discharge must be unobstructed. While it is difficult to predict the degree of warm air recirculation a unit installed as shown below would have its capacity and efficiency significantly reduced - possibly to the degree of nuisance trip-outs. Performance data is based on free air discharge.

Lateral Clearance

The condenser coil inlet must not be obstructed. A unit installed closer than the minimum recommended distance to a wall or other vertical obstruction may experience a combination of coil starvation and warm air recirculation. The recommended lateral clearances are depicted in the dimensional data section. These are estimates to service the unit and should be reviewed with the local Trane sales engineer at the jobsite for proper air-flow consideration.

Unit-to-Unit Clearance

Provide sufficient Unit-to-Unit clearance. Doubling the recommended single unit air-cooled chiller clearances will generally be adequate.

Walled Enclosure Installation

When the unit is placed in an enclosure, the top of the condenser fans should be no lower than the top of the enclosure. If they are consider ducting the top of the unit. Ducting individual fans, however, is not recommended. Such applications should always be reviewed with a Trane Sales Engineer.

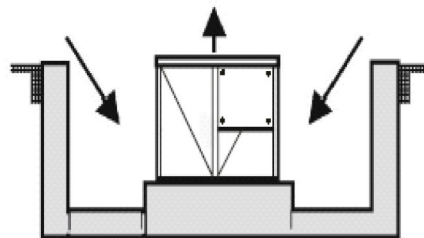

Water Treatment

Dirt, scale, products of corrosion and other foreign material in the water will adversely affect heat transfer between the water and system components. Foreign matter in the chilled water can also increase pressure drop and consequently reduce water flow. Proper water treatment must be determined locally and depends on the type of system and local water characteristics.

Controls

Temperature Controller

The temperature control sensor in CGAP is located in the leaving water. This sensor cannot be relocated. Doing so would result in improper unit operation.

Application Consideration

Anti-recycle Timer

All CGAP air-cooled chillers come with anti-recycle timer the function of which is to prevent rapid cycling of the compressors due to low load conditions or short water loops.

Loss Of Flow Protection

Full chilled water flow must be maintained through the evaporator while compressors are operating. Loss of flow may result in evaporator freeze-up. Though CGAP's have a loss of flow protection, a flow switch is added as a safety inter-lock for all the CGAP models.

Water Flow Limits

The minimum and maximum water flow rates are given in the "General Data" section of this catalog (page 4). Evaporator flow rates below the tabulated values will result in laminar flow causing scaling, stratification, freeze-up problems and poor temperature control. Flow rates exceeding the maximum tabulated values will result in very high pressure drop. Trane recommends that constant water flow be maintained at all times through the evaporator. Consult your local Trane

sales engineer if your application requires varying flows.

Temperature Limits

The maximum catalog leaving water temperature is 54°F (12°C). High leaving water temperature exceeding this may result in excessive suction temperatures and therefore inadequate compressor motor cooling. For temperatures below a 5°C (41°F), please consult your local Trane representative.

Supply Water Temperature Drop

The performance data for Trane CGAP air-cooled chillers is based on a chilled water temperature drop of 10°F (5°C). Chilled water temperature drops from 8 to 12°F may be used as long as minimum and maximum water temperature and minimum and maximum water flow rates are not violated.

Typical Water Piping

All building water piping must be flushed prior to making final connections to the chiller. To reduce heat loss and prevent condensation, insulation are to be applied. Expansion tanks are usually required so that chilled water volume

changes can be accommodated. A typical piping arrangement is shown below in Figure 1.

Short Water Loops

The proper location of the temperature control sensor is in the leaving water for CGAP's. This location allows the building to act as a buffer and help stabilize the return water temperatures. A short water loop (less than one minute in duration) will lead to erratic system operation. To prevent the effect of a short water loop the following items should be given careful consideration:

- 1 Add storage tank to increase the volume of water in the system and therefore reduce the rate of change of the return water temperature.
- 2 Use three-way modulating valves in lieu of two-position valves with cross-over pipes at the airside evaporators. The three-way valves will reduce the rate of change in the return water temperature.

Figure 1: Recommended piping components for a typical chiller installation.

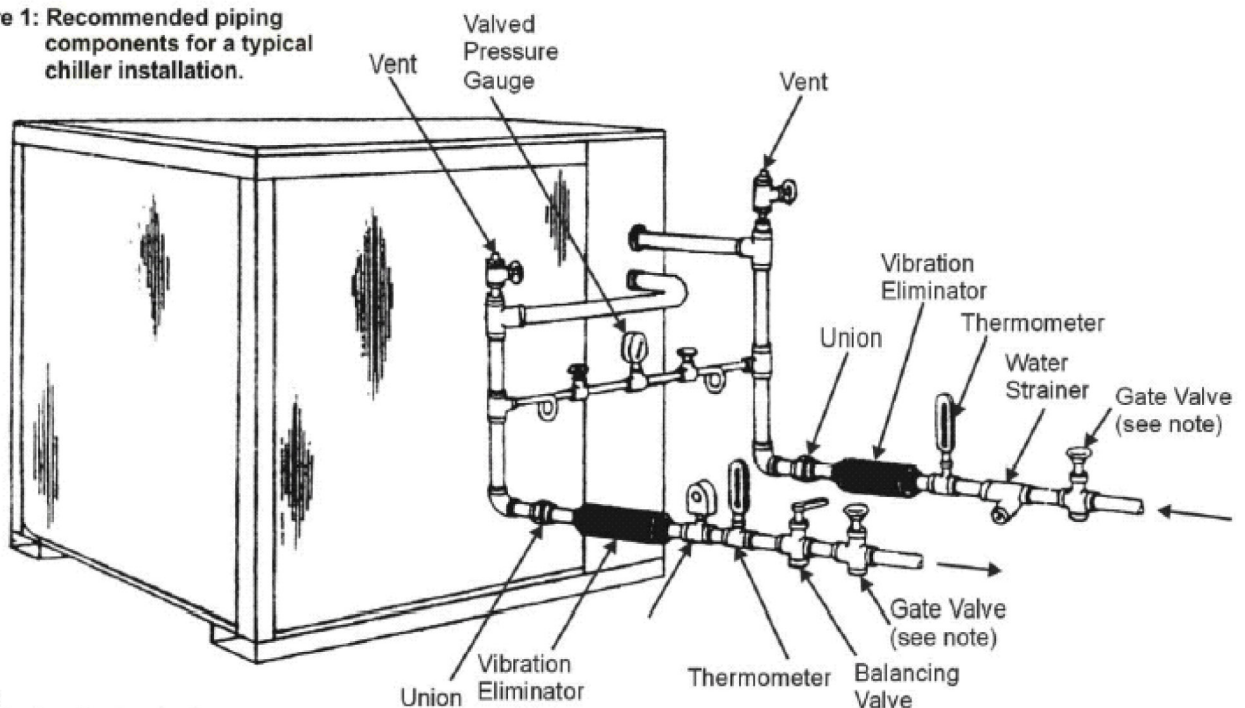

Note:

Provide shutoff valves in the evaporator inlet and outlet piping to facilitate water temperature sensor removal.



Mechanical Specification

CGAP 025 to CGAP 060

General :

Units shall be mounted on heavy gauge steel mounting and shall be weather-proofed. Units shall include hermetic scroll compressors, plate fin condenser coil, fan(s) and motor(s), controls and completely factory installed operating charge of oil and R-22 refrigerant. The units shall accept a single point, 3-phase power connection. All units shall be run tested at the factory. R-407C refrigerant shall be an option.

Casing

Unit casing shall be constructed of 1.2mm zinc coated heavy gauge galvanized steel. Exterior surfaces shall be cleaned, chemically treated and finished with weather-resistant baked polyester power finish. Unit shall have removable panels for access to major components and control. Controls shall be mounted in weatherproofed cabinets. The removable panels shall be held in place by "rapid access" clips and Allen key arrangements.

Refrigeration System

Unit shall have independent refrigeration circuit(s), system leak tested at the minimum 300 psig working pressure. Each refrigeration circuit shall have internal sub cooling circuits. Refrigeration filter drier, high low pressure schreder valve and sight glass with moisture indicator shall be provided as standard. Scroll compressor, shall be piped in parallel, with a passive oil management system. Passive oil management system maintains proper oil levels within compressors and has no moving parts. Each refrigeration Circuit will include an externally equalized expansion valve. The standard leaving chilled water temperature is 41 to 54 deg. F (5 - 12 deg C).

Compressors

Scroll compressors have simple mechanical design which provides inherently low vibration. Scroll compressors include centrifugal oil pump, built-in dirt separator, oil levels sight glass and oil charging valve. The direct-drive suction gas-cooled compressor motor have a voltage utilization range of plus or minus 10 percent of nameplate voltage. Motor winding thermal overload and over current protection shall be included as standard.

Condenser Coil

Coils shall be 3/8" copper tubes mechanically bonded to configured aluminum plate fin as standard. Factory proof and leak pressure tested at 450 psig.

Evaporator

The evaporator shall have independent refrigeration circuit. The evaporator shall be of plate-frame type design with a waterside working pressure of 350 psig and refrigerant side working pressure of 300 psig. For units with two evaporators, the connecting water manifold shall be provided. Evaporator shall be insulated with a 1cm close-cell insulation.

Condenser Fan And Motor

Direct drive, statically and dynamically balanced propeller fan with aluminum blades shall be used in draw-thru vertical discharge position. The motor shall be 3-Phase and for continuous air over duty. Motor overload protection shall be provided as standard.

Control - Carel Controls

The unit shall have a single-point, 3 phase power connection. Unit shall be operated via local I/O buttons on the controller. Furnished with customer interfacing terminals for remote opera-

tion in "AUTO" mode. Compressors contactors and controller shall be in a weather tight enclosure with knock-outs for site installed wiring. For control signal input voltage shall be 24Vac, voltage signal output voltage shall be 240Vac. Unit Controller shall provide all control functions including Chilled water pump control. Condenser Fan control, Compressors sequencing for leaving water temperature control. Safety controls, shall include phase reversal protection, Compressor/Fan Motor overload protection; High Motor Winding Temperature Cut-Out (on 15T compr. Only). High/Low refrigerant pressure monitoring. High refrigerant pressure controls. Low leaving water temperature detection, Chilled water flow switch and minimum On/Off timer function for compressors.

Human interface shall be Alpha-Numeric Display to monitor / configure unit operating parameters and view of diagnostic codes.

Optional Features

Corrosion-resistant finned condenser coil

A layer of resin is coated onto the surface of the fins to increase resistance to Corrosion in harsh environment conditions. A 500 hours, salt-spray test (in accordance to JIS-Z-2371) and humidity test (at 50deg. C, 98% relative humidity) had been performed to confirm the corrosion-Proof property of this coating.

Water Strainer

Strainers are a requirement for all water evaporators. These are available as a Factory ship with standard.



CGAP Performance Data (IP Units)

Cooling capacities / power input without glycol

Model CGAP	LWT deg.F	Entering air Temperature on condensing coil												
		(75 deg. F)			(85 deg. F)			(95 deg. F)				(105 deg. F)		
		C.Cap Mbh	P.Input K w	Water flow US gpm	C.Cap Mbh	P.Input K w	Water flow US gpm	C.Cap Mbh	P.Input K w	Water flow US gpm	Water dp ft.H2O	C.Cap Mbh	P.Input K w	Water flow US gpm
025	41.0	-	-	-	-	-	-	207.9	22.3	41.6	5.8	195.3	25.1	39.1
	43.0	242.4	17.5	48.5	229.8	19.7	46.0	216.1	22.3	43.2	6.2	202.4	25.1	40.5
	45.0	251.5	17.6	50.3	238.7	19.8	47.7	224.4	22.3	43.2	6.2	210.4	25.2	42.1
	47.0	259.7	17.6	51.9	246.1	19.8	49.2	231.0	22.4	46.2	7.0	217.0	25.3	43.4
	49.0	267.9	17.7	53.6	254.5	19.9	50.9	238.5	22.5	47.7	7.5	223.8	25.4	44.8
	51.0	276.6	17.8	55.3	262.9	19.9	52.6	246.6	22.6	49.3	7.9	231.4	25.4	46.3
	53.0	285.3	17.9	57.1	270.7	20.0	54.1	254.8	22.7	51.0	8.5	238.4	25.6	47.7
030	41.0	-	-	-	-	-	-	249.9	26.6	50.0	6.0	234.2	29.8	46.8
	43.0	291.9	21.0	58.4	276.2	23.6	55.2	259.9	26.7	52.0	6.4	244.0	29.8	48.8
	45.0	302.4	21.1	60.5	286.7	23.7	57.3	270.4	26.8	54.1	6.9	252.8	29.9	50.6
	47.0	312.9	21.2	62.6	297.2	23.8	59.4	279.1	26.9	55.8	7.4	262.2	29.9	52.4
	49.0	323.4	21.3	64.7	307.2	23.8	61.4	289.0	26.9	57.8	7.9	271.5	30.0	54.3
	51.0	333.9	21.4	66.8	317.1	23.9	63.4	299.3	27.0	59.9	8.4	280.8	30.1	56.2
	53.0	344.4	21.4	68.9	327.6	24.0	65.5	309.1	27.1	61.8	8.9	290.2	30.2	58.0
040	41.0	-	-	-	-	-	-	323.4	36.0	64.7	5.2	300.3	40.8	60.1
	43.0	379.9	28.0	76.0	358.3	31.6	71.7	335.7	36.0	67.1	5.6	312.0	40.9	62.4
	45.0	393.2	28.0	78.6	371.0	31.7	74.2	347.8	36.1	69.6	6.0	323.4	40.9	64.7
	47.0	405.8	28.1	81.2	383.1	31.8	76.6	359.3	36.2	71.9	6.3	334.1	41.0	66.8
	49.0	418.3	28.1	83.7	395.0	31.8	79.0	370.6	36.3	74.1	6.7	345.4	41.1	69.1
	51.0	430.9	28.1	86.2	407.5	31.9	81.5	382.6	36.4	76.5	7.1	356.8	41.1	71.4
	53.0	443.5	28.2	88.7	420.4	32.0	84.1	393.8	36.4	78.8	7.5	367.5	41.1	73.5
050	41.0	-	-	-	-	-	-	409.5	44.6	81.9	5.5	381.2	50.2	76.2
	43.0	479.5	35.0	95.9	453.2	39.4	90.6	426.2	44.6	85.2	6.0	396.3	50.3	79.3
	45.0	496.9	35.0	99.4	469.6	39.5	93.9	441.3	44.7	88.3	6.4	411.5	50.4	82.3
	47.0	513.5	35.1	102.7	484.8	39.5	97.0	456.2	44.7	91.2	6.8	426.1	50.5	85.2
	49.0	529.7	35.1	105.9	501.1	39.6	100.2	471.7	44.8	94.3	7.2	440.0	50.6	88.0
	51.0	546.3	35.2	109.3	517.1	39.7	103.4	486.9	44.8	97.4	7.7	454.3	50.6	90.9
	53.0	563.0	35.2	112.6	533.2	39.7	106.6	501.7	44.9	100.3	8.1	469.4	50.7	93.9
060	41.0	-	-	-	-	-	-	504.0	53.2	100.8	6.1	470.4	59.6	94.1
	43.0	584.8	42.0	117.0	556.4	47.2	111.3	523.3	53.2	104.7	6.5	489	59.6	97.8
	45.0	605.2	42.1	121.0	576.1	47.3	115.2	542.4	53.3	108.5	7.0	507.5	59.7	101.5
	47.0	625.6	42.2	125.1	595.4	47.4	119.1	561.1	53.4	112.2	7.4	525.0	59.8	105.0
	49.0	646.0	42.2	129.2	614.8	47.5	123.0	579.7	53.5	115.9	7.9	542.5	59.8	108.5
	51.0	667.3	42.3	133.5	634.7	47.6	126.9	599.0	53.5	119.8	8.4	560.6	59.9	112.1
	53.0	688.5	42.4	137.7	654.2	47.6	130.8	618.1	53.6	123.6	8.9	578.9	60.0	115.8

Notes:

1. Ratings based on ARI Standard 590-92.
2. Data based on evap. temperature drop of 10deg.F.
3. Ratings are also applicable for evaporator temperature drop of 8 to 12 deg.F.
4. Interpolation between points is permissible extrapolation beyond points is not allowed.
5. Kw input is for compressor only.



CGAP Performance Data (SI Units)

Cooling capacities / power input without glycol

Model CGAP	LWT deg.C	Entering air Temperature on condensing coil												
		(24 deg. C)			(29 deg. C)			(35 deg. C)				(41 deg. C)		
		C.Cap Kw	P.Input Kw	Water flow L/s	C.Cap Kw	P.Input Kw	Water flow L/s	C.Cap Kw	P.Input Kw	Water flow L/s	Water dp kPa	C.Cap Kw	P.Input Kw	Water flow L/s
025	5.0	-	-	-	-	-	-	60.3	22.3	2.57	16.4	57.2	25.1	2.44
	6.0	70.8	17.5	3.02	67.1	19.7	2.86	63.1	22.3	2.69	17.9	59.1	25.1	2.52
	7.0	73.2	17.6	3.13	69.5	19.8	2.97	65.4	22.3	2.79	19.2	61.2	25.2	2.61
	8.0	75.4	17.6	3.22	71.4	19.8	3.05	67.1	22.4	2.86	20.1	63.1	25.3	2.69
	9.0	77.5	17.7	3.31	73.5	19.9	3.14	68.9	22.5	2.94	21.2	64.6	25.4	2.76
	10.0	79.7	17.8	3.40	75.8	19.9	3.24	71.1	22.6	3.03	22.5	66.8	25.4	2.85
	11.0	82.1	17.9	3.51	78.0	20.0	3.33	73.2	22.7	3.13	23.8	68.6	25.6	2.93
	12.0	84.3	17.9	3.60	80.0	20.0	3.41	75.4	22.7	3.22	25.1	70.5	25.6	3.01
030	5.0	-	-	-	-	-	-	72.5	26.6	3.09	17.3	68.6	29.8	2.93
	6.0	85.2	21.0	3.64	80.6	23.6	3.44	75.8	26.6	3.24	18.8	71.2	29.8	3.04
	7.0	88.0	21.1	3.76	83.4	23.7	3.56	78.8	26.7	3.36	20.2	73.5	29.9	3.14
	8.0	90.8	21.2	3.87	86.1	23.8	3.68	80.9	26.8	3.45	21.2	76.0	29.9	3.24
	9.0	93.5	21.3	3.99	88.9	23.8	3.79	83.5	26.9	3.56	22.6	78.5	30.0	3.35
	10.0	96.3	21.4	4.11	91.4	23.9	3.90	86.1	26.9	3.68	23.9	80.9	30.1	3.45
	11.0	99.1	21.4	4.23	94.1	24.0	4.02	88.9	27.0	3.79	25.4	83.4	30.2	3.56
	12.0	101.8	21.5	4.35	96.9	24.0	4.14	91.4	27.1	3.90	26.7	85.8	30.2	3.66
040	5.0	-	-	-	-	-	-	93.8	36.0	4.00	14.9	88.0	40.8	3.76
	6.0	110.9	28.0	4.73	104.6	31.6	4.46	98.0	36.0	4.18	16.2	91.1	40.9	3.89
	7.0	114.4	28.0	4.88	108.0	31.7	4.61	101.2	36.1	4.32	17.2	94.1	40.9	4.02
	8.0	117.8	28.1	5.03	111.2	31.8	4.75	104.3	36.2	4.45	18.2	96.9	41.0	4.14
	9.0	121.1	28.1	5.17	114.3	31.8	4.88	107.2	36.3	4.58	19.2	99.8	41.1	4.26
	10.0	124.4	28.1	5.31	117.5	31.9	5.02	110.3	36.4	4.71	20.2	102.9	41.1	4.39
	11.0	127.7	28.2	5.45	120.9	32.0	5.16	113.5	36.4	4.85	21.3	105.8	41.1	4.52
	12.0	131.1	28.3	5.59	124.3	32.0	5.30	116.3	36.5	4.96	22.3	108.6	41.2	4.63
050	5.0	-	-	-	-	-	-	118.8	44.6	5.07	16.1	111.7	50.2	4.77
	6.0	140.0	35.0	5.97	132.3	39.4	5.65	124.4	44.6	5.31	17.6	115.7	50.3	4.94
	7.0	144.6	35.0	6.17	136.7	39.5	5.84	128.4	44.7	5.48	18.7	119.7	50.4	5.11
	8.0	149.1	35.1	6.36	140.6	39.5	6.00	132.3	44.7	5.65	19.7	123.7	50.5	5.28
	9.0	153.2	35.1	6.54	144.9	39.6	6.18	136.4	44.8	5.82	20.9	127.2	50.6	5.43
	10.0	157.7	35.2	6.73	149.2	39.7	6.37	140.4	44.8	5.99	22.1	131.1	50.6	5.59
	11.0	162.0	35.2	6.91	153.4	39.7	6.55	144.4	44.9	6.16	23.3	134.7	50.7	5.75
	12.0	166.4	35.3	7.10	157.7	39.8	6.73	148.3	45.0	6.33	24.5	138.9	50.8	5.93
060	5.0	-	-	-	-	-	-	146.2	53.2	6.24	17.6	137.8	59.6	5.88
	6.0	170.7	42.0	7.29	162.4	47.2	6.93	152.7	53.2	6.52	19.1	142.7	59.6	6.09
	7.0	176.1	42.1	7.52	167.7	47.3	7.16	157.8	53.3	6.74	20.4	147.7	59.7	6.30
	8.0	181.5	42.0	7.29	162.4	47.2	6.93	152.7	53.2	6.52	19.1	142.7	59.6	6.09
	9.0	186.9	42.2	7.98	177.8	47.5	7.59	167.7	53.5	7.16	22.8	156.9	59.8	6.70
	10.0	192.3	42.3	8.21	183.1	47.6	7.81	172.6	53.5	7.37	24.1	161.5	59.9	6.89
	11.0	198.1	42.4	8.46	188.3	47.6	8.04	177.8	53.6	7.59	25.5	166.4	60.0	7.10
	12.0	203.5	42.5	8.69	193.4	47.7	8.25	182.7	53.7	7.80	26.8	171.0	60.1	7.31

Notes:

1. Ratings based on ARI Standard 590-92.
2. Data based on evap. temperature drop of 10deg.F.
3. Ratings are also applicable for evaporator temperature drop of 8 to 12 deg.F.
4. Interpolation between points is permissible extrapolation beyond points is not allowed.
5. Kw input is for compressor only.

Pressure Drop, Correction Factor.

Correction factor - CGAP

Chilled water outflow temperature °C	Ethylene glycol mass concentration (%)	Correction factor			
		Flow rate	Pressure drop	Input power	Cooling capacity
12	30	1.11	1.20	1.005	0.98
5	30	1.11	1.24	1.005	0.97
4	10	1.02	1.08	1	1
0	20	1.05	1.19	1	1
-4	27	1.08	1.29	1	1
-8	33	1.10	1.46	1	1
-12	37	1.12	1.62	1	1

Note: Correction factor should be considered when ethylene glycol is used in the chilled water system. (actual value = original value x correction factor)

Selection Procedures

The chiller capacity tables presented in the 'Performance data' section cover the most frequently encountered leaving water temperatures. To select a CGAP air-cooled chiller, the following information is required;

- 1) Design system load.
- 2) Design leaving chilled water temperature.
- 3) Design chilled water temperature drop.
- 4) Design ambient temperature.

Evaporator chilled water flow rate can be determined as follows;

- 1) **English unit ; $500 \times \text{US gpm} \times \text{dT} = \text{Q}$**
where, dT is in deg.F and Q is cooling load (Btuh).
- 2) **SI unit ; $4.184 \times \text{L/s} \times \text{dT} = \text{Q}$**
where, dT is in deg.C and Q is cooling load (kW).

Selection example (English unit)

Given :
 Required system load = 430 Mbh.
 Leaving chilled water temperature, (LCWT) = 45 F
 Chilled water temperature drop = 10 F
 Design ambient temperature = 95 F
 Evaporator fouling factor = 0

Calculation

- 1) From the 'Performance data' section (English unit), page 9, a CGAP050 will have a cooling load capacity of 441.3 Mbh with a compressor power input of 44.7 kW at the given condition.
- 2) Calculate the required chilled water flow rate.
 From, $500 \times \text{US gpm} \times \text{dT} = \text{Q}$,
(where, $\text{Q} = 441.3 \text{ Mbh} \times 1000 = 441,300 \text{ Btuh}$, while $\text{dT} = 10\text{F}$)
 Flow rate in US gpm = $\text{Q} / (500 \times \text{dT})$
 $= 441,300 / (500 \times 10)$
 $= 88.3$

- 3) Determine evaporator water pressure drop using the flow rate and the evaporator water pressure drop curves found in page 12. Entering the curve at 88.3 US gpm will yield a pressure drop at 6 fl. water

OR

from simple reading off the table in the 'performance date' section (english units) on page 9, which will yield, a chilled water flow rate of 88.3 US gpm and a corresponding evaporator water pressure drop of 6.4 ft, water.

Selection example (SI unit)

Given :
 Required system load = 126 kW.
 Leaving chilled water temperature, (LCWT) = 7 deg.C
 Chilled water temperature drop = 5.6 deg.C
 Design ambient temperature = 35 deg.C
 Evaporator fouling factor = 0

Calculation

- 1) From the 'Performance data' section (SI unit), on page 10, a CGAP050 will have a cooling load capacity of 128.4 kW with a compressor power input of 44.7 kW at the given condition.
- 2) Calculate the required chilled water flow rate.
 From, $4.184 \times \text{L/s} \times \text{dT} = \text{Q}$,
(where, $\text{Q} = 128.4 \text{ kW}$ and $\text{dT} = 5.6 \text{ deg.C}$)
 Flow rate, L/s = $\text{Q} / (4.184 \times \text{dT})$
 $= 128.4 / (4.184 \times 5.6)$
 $= 5.48$
- 3) Determine evaporator water pressure drop using the flow rate and the evaporator water pressure drop curves found on page 12. Entering the curve at 5.48 L/s will yield a pressure drop of 19 kPa.

OR

from simple reading off the table in the 'performance date' section (SI units) on page 10, which will yield, a chilled water flow rate of 5.48 L/s and a corresponding evaporator water pressure drop of 18.7 kPa.

Dimensional Drawing CGAP 025

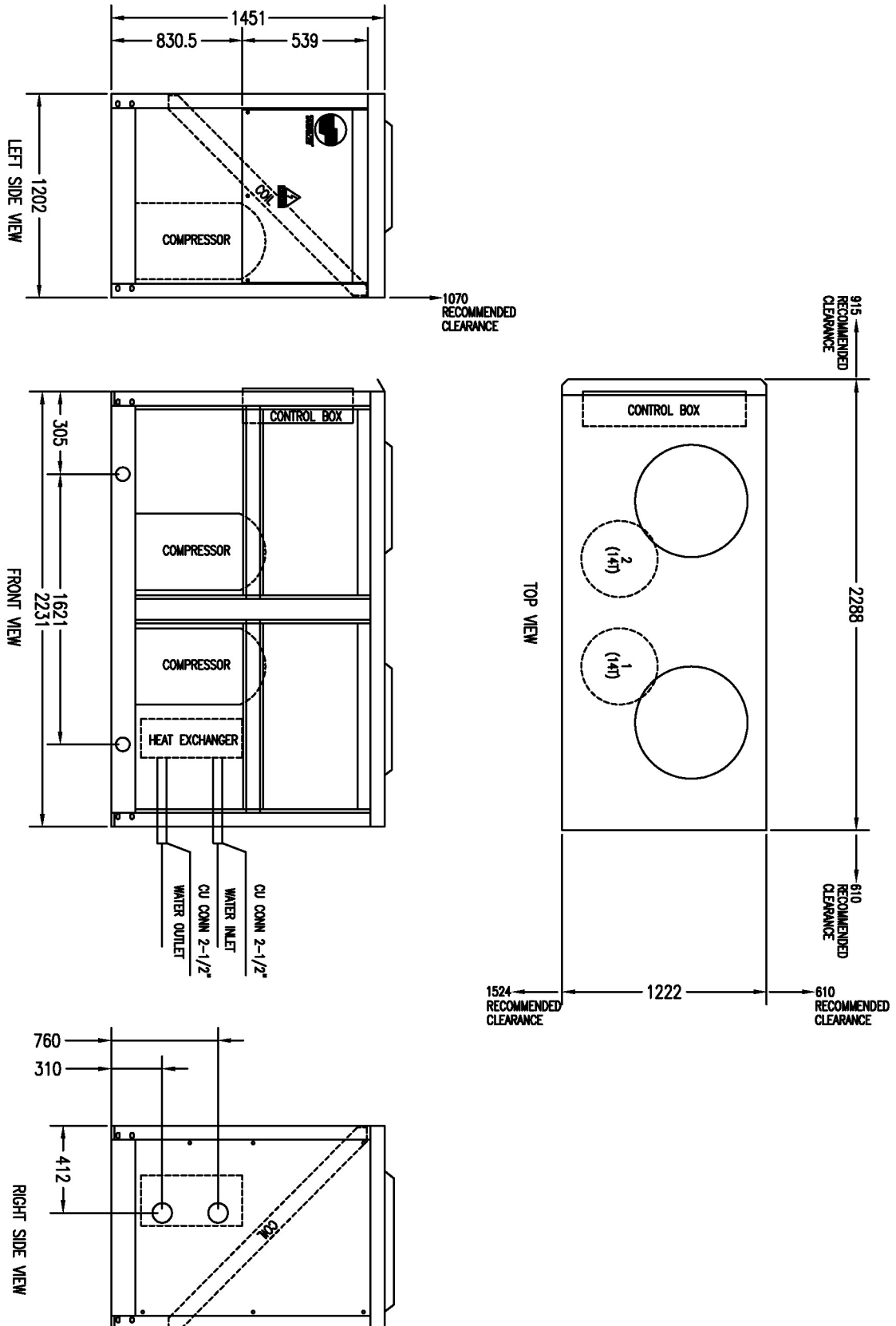

Dimensional Drawing CGAP 030

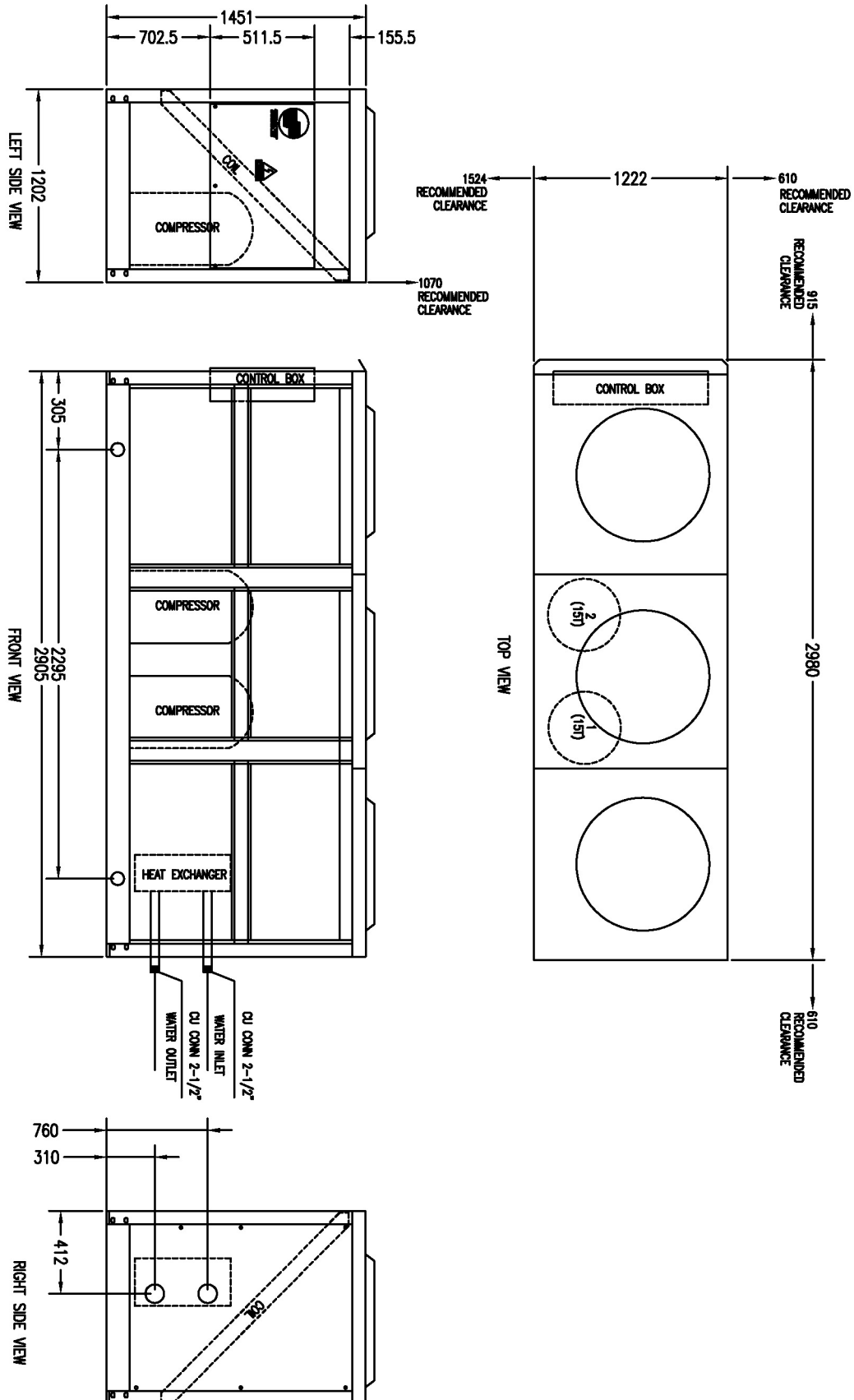

Dimensional Drawing CGAP 040/050

MODEL	DIMENSION (MILLIMETER UNIT.)																					
	A	B	C	D	E	F	G	H	J	K	L	M	N	P	Q	R	S	T	U	V		
CGAP040D1A0A00A	2579.5	1770	1923	2505	1904	763.5	313.5	414	-	-	-	-	-	-	-	-	-	-	-	-	-	
CGAP050D1A0A00A	2579.5	1770	1923	2505	1904	763.5	313.5	414	-	-	-	-	-	-	-	-	-	-	-	-	-	

DIMENSIONAL DATA

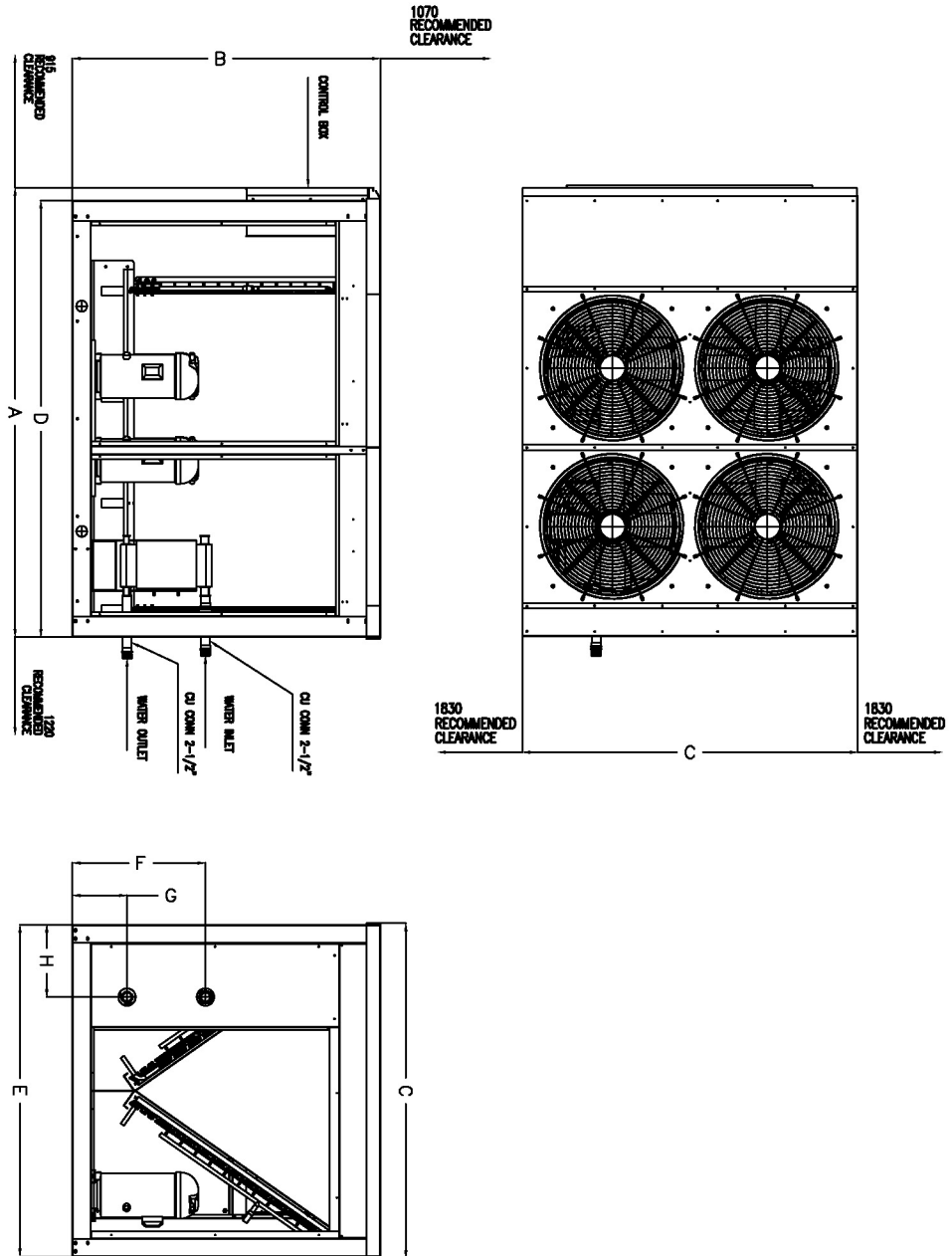

Dimensional Drawing CGAP 060

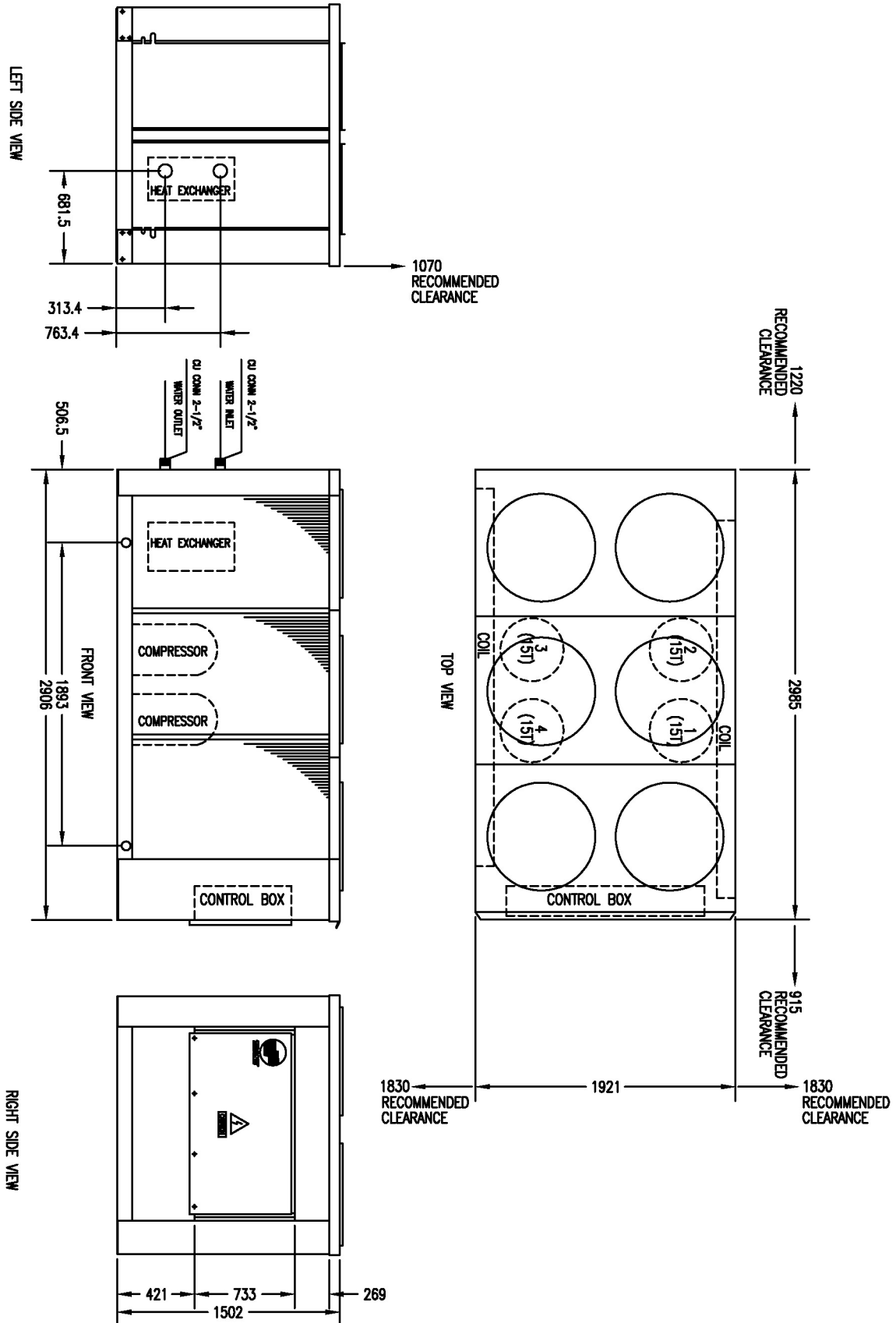

Wiring Diagram

CGAP 025/030 Power DOL Starter c/w Carel Controller

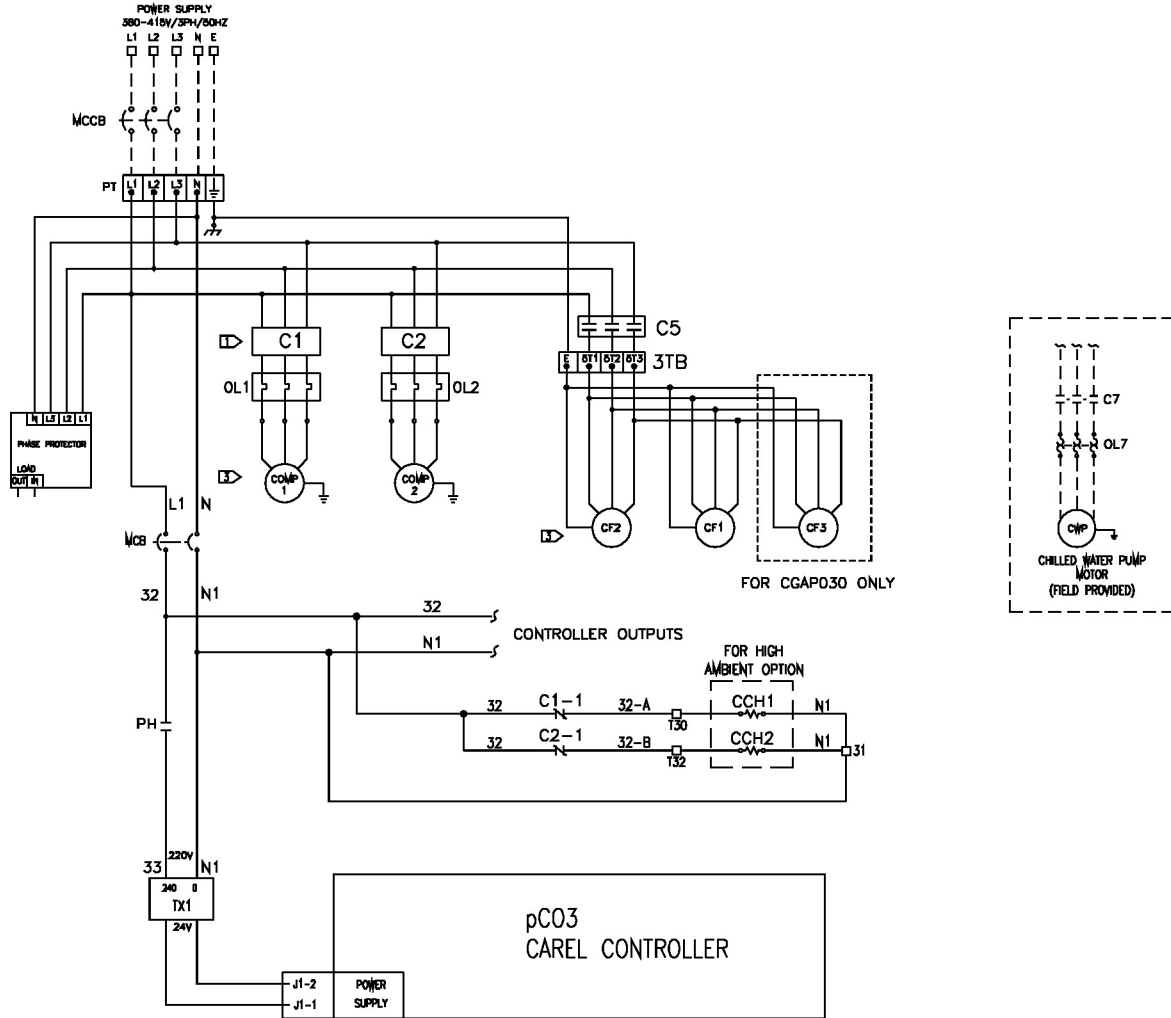

NOTE :-
FOR CGAP025/030 - COMPRESSOR OVERLOAD ARE INTERNALLY PROTECTED

LEGEND	DESCRIPTION
C1,C2	CONTACTOR, for COMPRESSOR #
C5	CONTACTOR, for CONDENSING FAN #
C7	CONTACTOR, for CHILLED WATER PUMP MOTOR
CCH #	CRANKCASE HEATER for COMPRESSOR #
CF	CONDENSER FAN #
COMP	COMPRESSOR #
WDPS	DIFFERENTIAL PRESSURE SWITCH, WATER
WFS	WATER FLOW SWITCH
HMT	HIGH MOTOR WINDING THERMOSTAT #
HPCO	HIGH PRESSURE CUT-OUT #
IWT	INLET WATER TEMPERATURE
LPCO	LOW PRESSURE CUT-OUT #
MCB	MINIATURE CIRCUIT BREAKER
pC03	CAREL CONTROLLER, pC03
OL	OVERLOAD RELAY, for COMPRESSOR #
OWT	OUTLET WATER TEMPERATURE
PT	POWER TERMINAL
PH	PHASE SEQUENCE / REVERSAL RELAY
R	CONTROL RELAY
TB	TERMINAL BLOCK
TX1	SWITCHING POWER SUPPLY 220-240V:24V
□	TERMINATION BLOCK, CONTROL
----	SUPPLIED & INSTALLED BY CUSTOMER
=====	FACTORY INSTALLED

NOTES:

- ☐ COMPRESSOR STARTER
- ☒ REMOVE JUMPER TO INSTALL EXTERNAL CONTROL DEVICE, IF EXIST.
- ☒ COMPRESSOR AND CF MOTOR ARE INTERNALLY PROTECTED.

COMPRESSOR LAYOUT

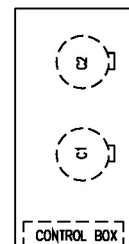

WARNING

HAZARDOUS VOLTAGE!
DISCONNECT ALL ELECTRIC POWER INCLUDING REMOTE DISCONNECTS BEFORE SERVICING.

FAILURE TO DISCONNECT POWER BEFORE SERVICING CAN CAUSE SEVERE PERSONAL INJURY OR DEATH.

IMPORTANT

USE COPPER CONDUCTORS ONLY TO PREVENT EQUIPMENT DAMAGE. UNIT TERMINALS ARE NOT DESIGNED TO ACCEPT ANY OTHER WIRING.

Wiring Diagram

CGAP 025/030 Power DOL

Starter c/w Carel Controller

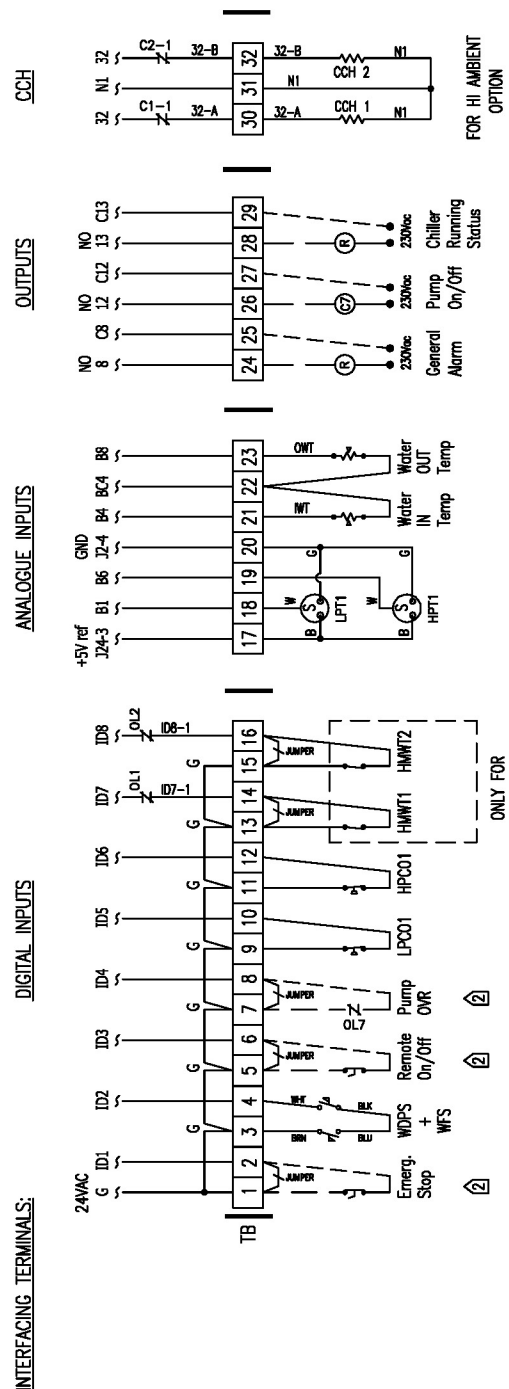
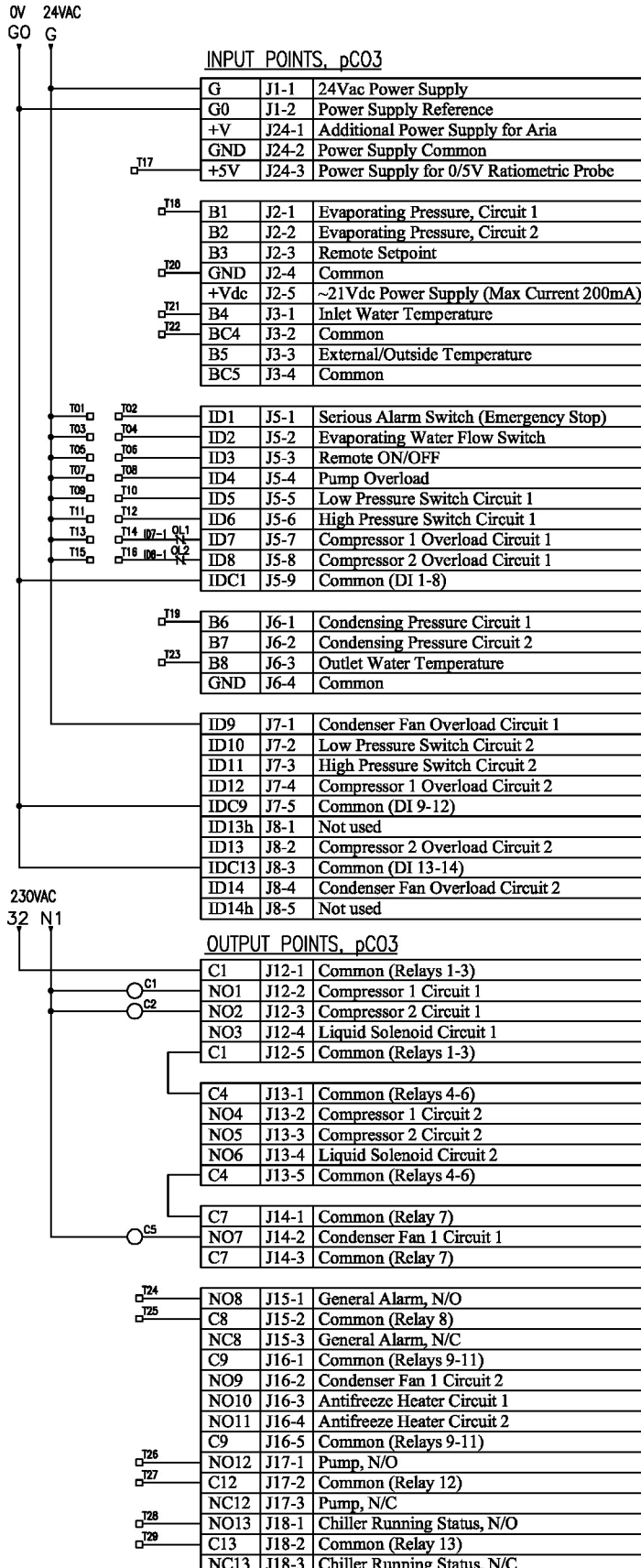

Wiring Diagram CGAP 040/050 Power DOL Starter c/w Carel Controller

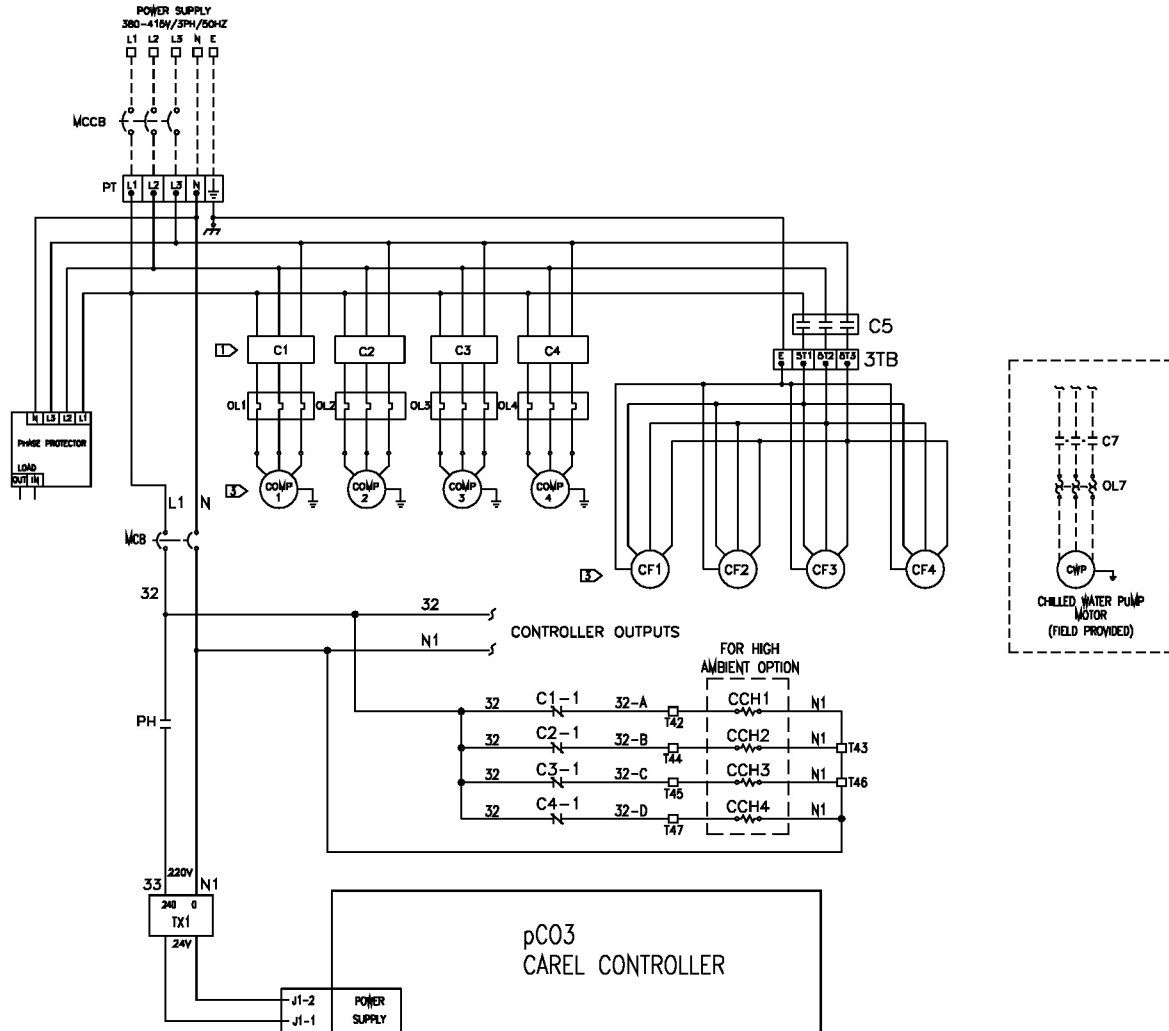

NOTE :-
FOR CGAP040-050 - COMPRESSOR OVERLOAD ARE INTERNALLY PROTECTED

LEGEND	DESCRIPTION
C1,C2,C3,C4	CONTACTOR, for COMPRESSOR #
C5	CONTACTOR, for CONDENSING FAN #
C7	CONTACTOR, for CHILLED WATER PUMP MOTOR
CCH #	CRANKCASE HEATER for COMPRESSOR #
CF	CONDENSER FAN #
COMP	COMPRESSOR #
WDPS	DIFFERENTIAL PRESSURE SWITCH, WATER
WFS	WATER FLOW SWITCH
HMWT	HIGH MOTOR WINDING THERMOSTAT #
HPCO	HIGH PRESSURE CUT-OUT #
IWT	INLET WATER TEMPERATURE
LPCO	LOW PRESSURE CUT-OUT #
MCB	MINIATURE CIRCUIT BREAKER
pC03	CAREL CONTROLLER, pC03
OL	OVERLOAD RELAY, for COMPRESSOR #
OWT	OUTLET WATER TEMPERATURE
PT	POWER TERMINAL
PH	PHASE SEQUENCE / REVERSAL RELAY
R	CONTROL RELAY
TB	TERMINAL BLOCK
TX1	SWITCHING POWER SUPPLY 220-240V;24V
□	TERMINATION BLOCK, CONTROL
-----	SUPPLIED & INSTALLED BY CUSTOMER
—————	FACTORY INSTALLED

NOTES:

- ① COMPRESSOR STARTER
- ② REMOVE JUMPER TO INSTALL EXTERNAL CONTROL DEVICE, IF EXIST.
- ③ COMPRESSOR AND CF MOTOR ARE INTERNALLY PROTECTED.

⚠ WARNING
HAZARDOUS VOLTAGE!
DISCONNECT ALL ELECTRIC POWER INCLUDING REMOTE DISCONNECTS BEFORE SERVICING.
FAILURE TO DISCONNECT POWER BEFORE SERVICING CAN CAUSE SEVERE PERSONAL INJURY OR DEATH.

IMPORTANT
USE COPPER CONDUCTORS ONLY TO PREVENT EQUIPMENT DAMAGE. UNIT TERMINALS ARE NOT DESIGNED TO ACCEPT ANY OTHER WIRING.

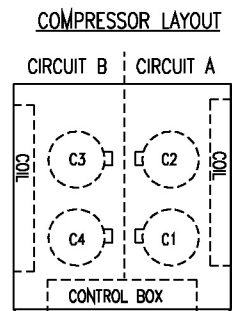

Wiring Diagram

CGAP 040/050 Power DOL

Starter c/w Carel Controller

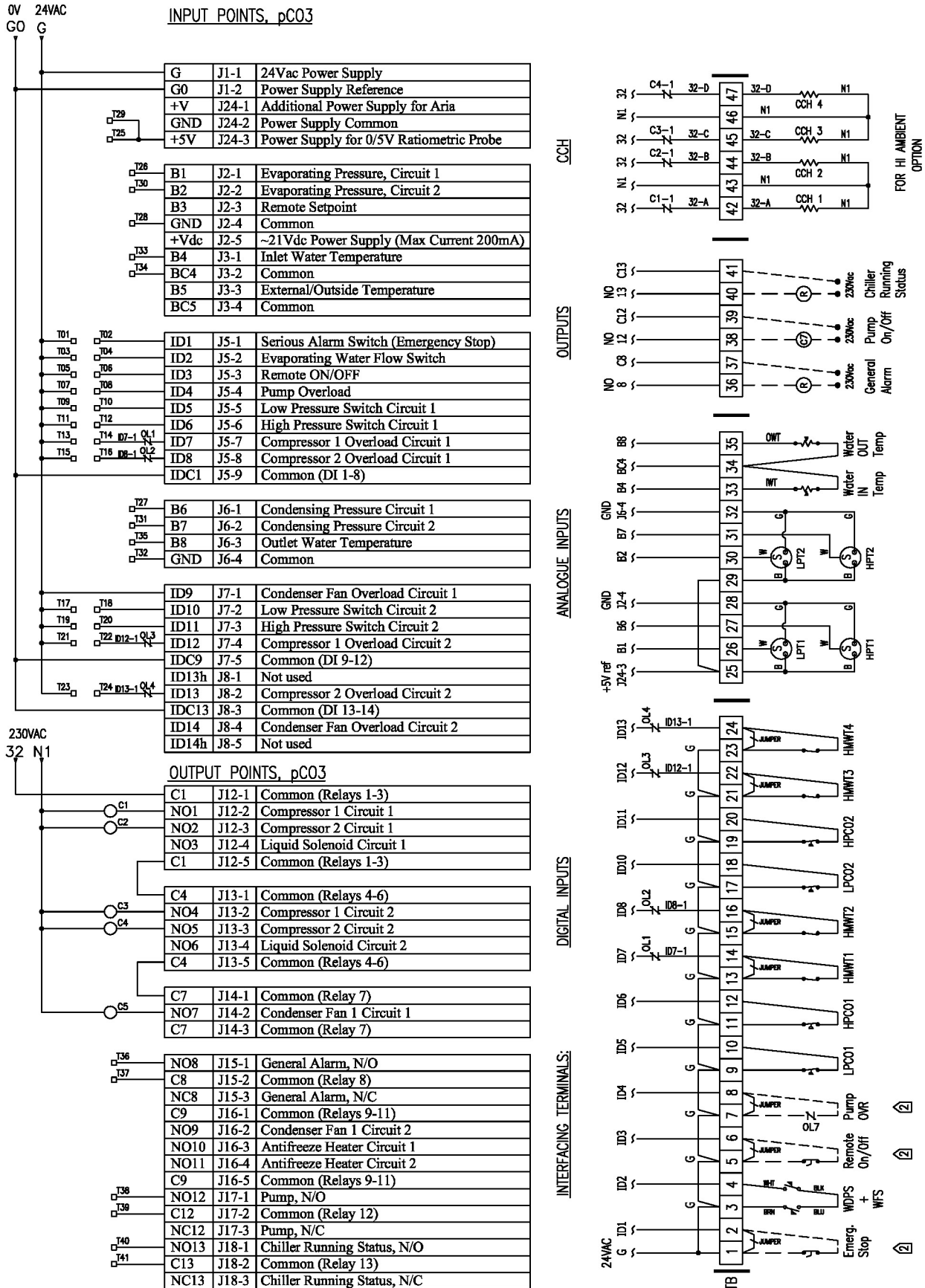

Wiring Diagram CGAP 060 Power DOL Starter c/w Carel Controller

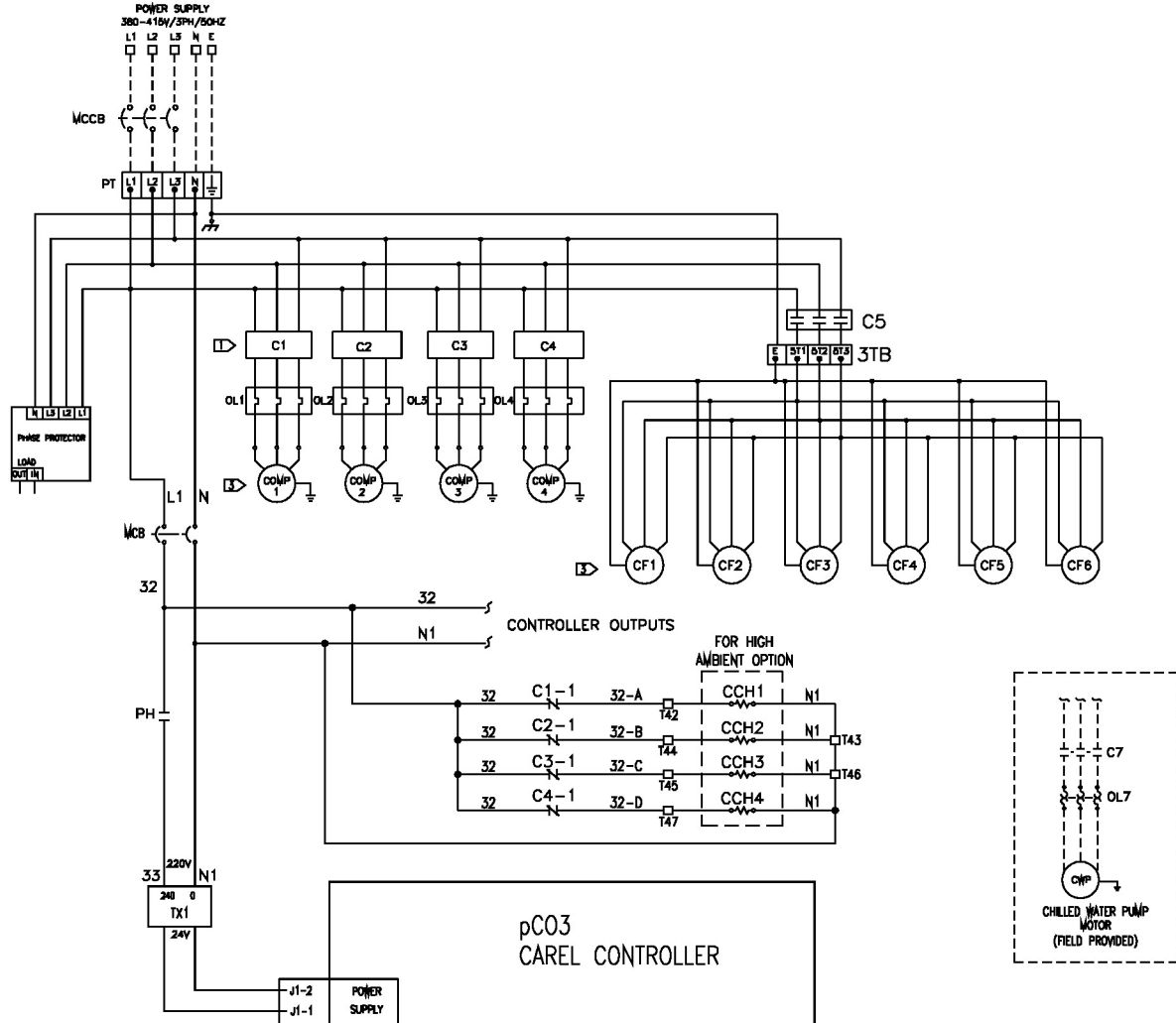

NOTE :-
FOR CGAP060 - COMPRESSOR OVERLOAD ARE INTERNALLY PROTECTED

LEGEND	DESCRIPTION
C1,C2,C3,C4	CONTACTOR, for COMPRESSOR #
C5	CONTACTOR, for CONDENSING FAN #
C7	CONTACTOR, for CHILLED WATER PUMP MOTOR
CCH #	CRANKCASE HEATER for COMPRESSOR #
CF	CONDENSER FAN #
COMP	COMPRESSOR #
WDPS	DIFFERENTIAL PRESSURE SWITCH, WATER
WFS	WATER FLOW SWITCH
HMWT	HIGH MOTOR WINDING THERMOSTAT #
HPCO	HIGH PRESSURE CUT-OUT #
IWT	INLET WATER TEMPERATURE
LPCO	LOW PRESSURE CUT-OUT #
MCB	MINIATURE CIRCUIT BREAKER
pC03	CAREL CONTROLLER, pC03
OL	OVERLOAD RELAY, for COMPRESSOR #
OWT	OUTLET WATER TEMPERATURE
PT	POWER TERMINAL
PH	PHASE SEQUENCE / REVERSAL RELAY
R	CONTROL RELAY
TB	TERMINAL BLOCK
TX1	SWITCHING POWER SUPPLY 220-240V;24V
□	TERMINATION BLOCK, CONTROL
-----	SUPPLIED & INSTALLED BY CUSTOMER
—————	FACTORY INSTALLED

NOTES:

- ① COMPRESSOR STARTER
- ② REMOVE JUMPER TO INSTALL EXTERNAL CONTROL DEVICE, IF EXIST.
- ③ COMPRESSOR AND CF MOTOR ARE INTERNALLY PROTECTED.

⚠ WARNING
HAZARDOUS VOLTAGE!
DISCONNECT ALL ELECTRIC POWER INCLUDING REMOTE DISCONNECTS BEFORE SERVICING.
FAILURE TO DISCONNECT POWER BEFORE SERVICING CAN CAUSE SEVERE PERSONAL INJURY OR DEATH.

IMPORTANT
USE COPPER CONDUCTORS ONLY TO PREVENT EQUIPMENT DAMAGE. UNIT TERMINALS ARE NOT DESIGNED TO ACCEPT ANY OTHER WIRING.

COMPRESSOR LAYOUT

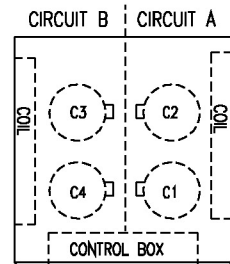

Wiring Diagram

CGAP 060 Power DOL

Starter c/w Carel Controller

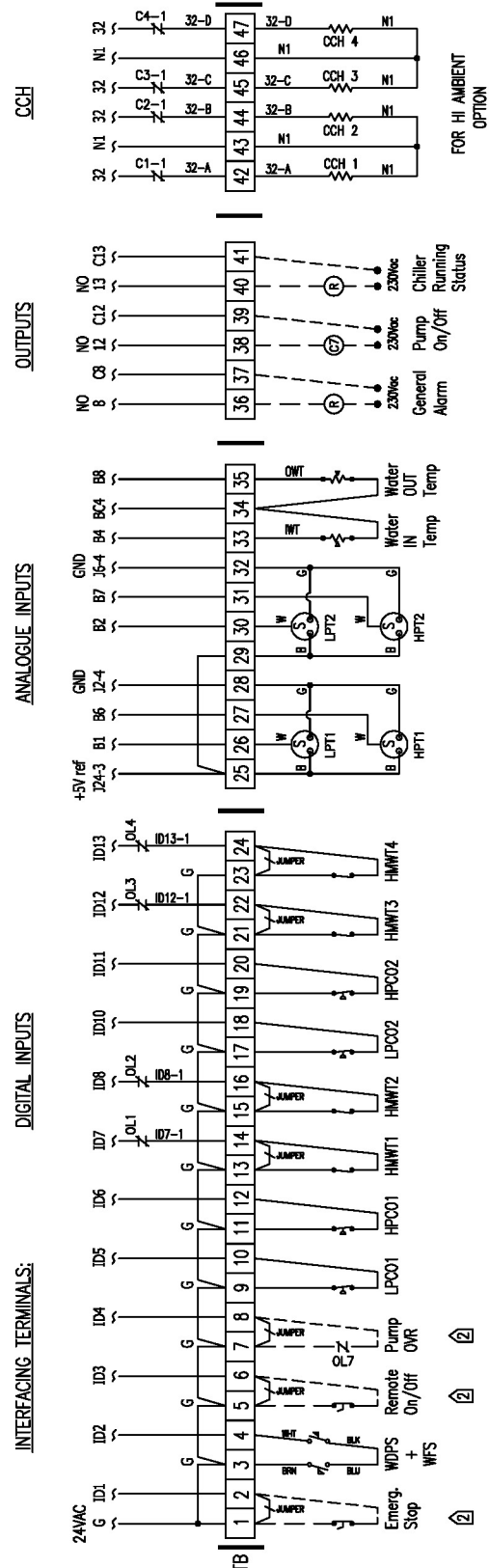
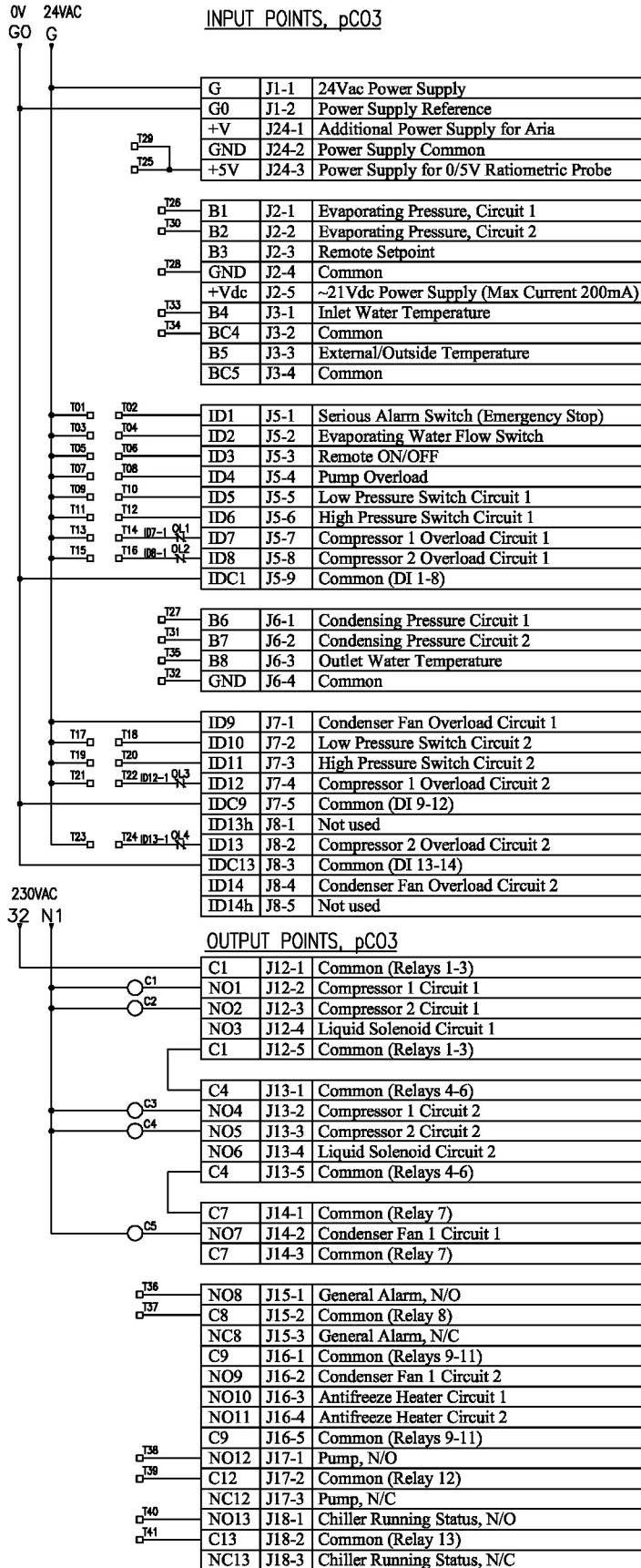

Standard Conversion Table

To Convert Form:	To	Multiply By:
Length		
Feet (ft)	Meters (m)	.30481
Inches (In)	Millimeters (mm)	25.4
Area		
Square Feet (ft ²)	Square Meters (m ²)	.093
Square Inches (In ²)	Square Millimeters (mm ²)	645.2
Cubic Feet (ft ³)	Cubic Meters (m ³)	.0283
Cubic Inches (In ³)	Cubic Millimeters (mm ³)	16387
Gallons (gal)	Litres (l)	3.785
Gallons (gal)	Cubic Meters (m ³)	.003785
Flow		
Cubic feet/min (cfm)	Cubic meters/second (m ³ /s)	.000472
Cubic feet/min (cfm)	Cubic meters/hr (m ³ /hr)	1.69884
Gallons/minute (GPM)	Cubic meters/hr (m ³ /hr)	.2271
Gallons/minute (GPM)	Litres/second (l/s)	.06308
Velocity		
Feet per minute (ft/m)	Meters per second (m/s)	.00508
Feet per second (ft/s)	Meters per second (m/s)	.3048
Energy and Power and Capacity		
British Thermal Units (Btu/h)	Kilowatt (kW)	.000293
British Thermal Units (Btu/h)	Kilocalorie (Kcal)	.252
Tons (refrig. effect)	Kilowatt (refrig. effect)	3.516
Tons (refrig. effect)	Kilocalorie-per hour (Kcal/hr)	3024
Horsepower	Kilowatt (kW)	.7457
Pressure		
Feet of water (ftH ₂ O)	Pascals (PA)	2990
Inches of water (InH ₂ O)	Pascals (PA)	249
Pounds per square inch (PSI*)	Pascals (PA)	6895
PSI*	Bar or KG/CM ²	0.06895
*PSIG		

P-H DIAGRAM - BLENDS

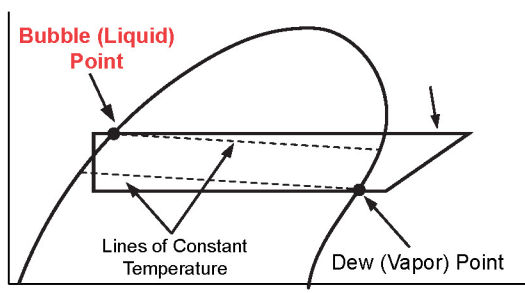

To determine superheat, use Dew (Vapor) Point values.
To determine subcooling, use Bubble (Liquid) Point values.

Useful Formulas

Note: 3-phase amps or KVA can be used in single-phase formulas by multiplying average phase leg current time $\sqrt{3}$ or 1.73

Example:

$$KVA = \frac{V \times A \times 1.73}{1000}$$

KW = Real Power; KVA = Apparent Power

$$KW = KVA \times \text{Power Factor} = \frac{V \times A \times \text{Power Factor}}{1000}$$

$$\text{Motor KW} = \frac{HP \times .746}{\text{Efficiency}}$$

$$\text{Motor KVA} = \frac{HP \times .746}{\text{Eff.} \times \text{PowerFactor}}$$

$$\text{Motor HP} = \frac{KW \times \text{Eff.}}{.746} = \frac{KVA \times \text{Power Factor} \times \text{Eff.}}{.746}$$

$$\text{Pump HP} = \frac{GPM \times \text{Total Heat (Ft. Water)}}{\text{Pump Eff.} \times 3960}$$

$$HP = \frac{\text{Torque (lb.-ft)} \times \text{RPM}}{5250}$$

$$\text{Temperature : } \frac{^{\circ}\text{C}}{5} = \frac{^{\circ}\text{F} - 32}{9}$$

$$\text{Refrig. Tons} = \frac{\text{Btu/h}}{12000} = \frac{\text{GPM} \times \Delta T}{24}$$

Standard Conversion Table

Pressure Temperature

Temp °F	R22 Pressure psia	R123 Pressure psia	R134a Pressure psia
0.00	38.728	1.963	21.171
5.00	42.960	2.274	23.777
10.00	47.536	2.625	26.628
15.00	52.475	3.019	29.739
20.00	57.795	3.460	33.124
25.00	63.514	3.952	36.800
30.00	69.651	4.499	40.784
35.00	76.225	5.106	45.092
40.00	83.255	5.778	49.741
45.00	90.761	6.519	54.749
50.00	98.763	7.334	60.134
55.00	107.28	8.229	65.913
60.00	116.33	9.208	72.105
65.00	125.94	10.278	78.729
70.00	136.13	11.445	85.805
75.00	146.92	12.713	93.351
80.00	158.33	14.090	101.39
82.08	-	14.696	-
85.00	170.38	15.580	109.93
90.00	183.09	17.192	119.01
95.00	196.50	18.931	128.65
100.00	210.61	20.804	138.85
105.00	225.46	22.819	149.65
110.00	241.06	24.980	161.07
115.00	257.45	27.297	173.14
120.00	274.65	29.776	185.86
125.00	292.69	32.425	199.28
130.00	311.58	35.251	213.41
135.00	331.37	38.261	228.28
140.00	352.08	41.464	243.92
145.00	373.74	44.868	260.36

Pressure Temperature

Pressure psia	R407C Temp °F		R410A Temp °F	
	Bubble	Dew	Bubble	Dew
44.00	-0.28	11.47	-16.91	-16.79
46.00	1.86	13.56	-14.90	-14.77
48.00	3.92	15.58	-12.95	-12.82
50.00	5.93	17.53	-11.07	-10.94
55.00	10.68	22.18	-6.59	-6.46
60.00	15.11	26.50	-2.42	-2.29
65.00	19.27	30.56	1.49	1.63
70.00	23.19	34.39	5.17	5.32
75.00	26.90	38.01	8.66	8.81
80.00	30.43	41.46	11.98	12.13
85.00	33.80	44.74	15.14	15.30
90.00	37.02	47.88	18.17	18.32
95.00	40.11	50.89	21.06	21.22
100.00	43.08	53.78	23.85	24.01
110.00	48.70	59.24	29.12	29.28
120.00	53.95	64.35	34.03	34.20
130.00	58.87	69.13	38.65	38.82
140.00	63.53	73.65	43.00	43.18
150.00	67.94	77.93	47.13	47.31
160.00	72.13	81.99	51.05	51.23
170.00	76.14	85.87	54.79	54.98
180.00	79.97	89.58	58.37	58.56
190.00	83.65	93.13	61.08	61.99
200.00	87.18	96.55	65.10	65.29
220.00	93.88	103.00	71.34	71.54
240.00	100.14	109.02	77.16	77.36
260.00	106.02	114.67	82.63	82.83
280.00	111.58	119.99	87.79	87.99
300.00	116.85	125.03	92.68	92.88
320.00	121.86	129.81	97.32	97.53
340.00	126.65	134.36	101.75	101.95
360.00	131.23	138.70	105.99	106.19
380.00	135.63	142.86	110.05	110.24
400.00	139.85	146.84	113.94	114.13
450.00	149.77	156.11	123.06	123.24
500.00	158.90	164.54	131.41	131.58
550.00	167.37	172.23	139.12	139.27
600.00	175.31	179.23	146.28	146.40

*PSIG = PSIA - 14.7



TraneThailand
 30th-31st Floor Vanit Building II
 1126/2 New Petchburi Rd. Makkasan
 Rachthevee, Bangkok 10400
AmairLimited
 999/1 Mu 9 Bangna-Trad Km. 19 Rd.
 Bangchalong, Bangplee
 Samutprakarn 10540
<http://www.trane.com>

Literature Order Number: CGAP- CATALOGUE_Rev.A (690826950001)

Date: Oct 2017

Supersedes: -

Stocking Location: Bangkok, Thailand

Trane has a policy of continuous product and product data improvement and reserves the right to change design and specifications without notice.